



(Signature Series™)

L-861T Elevated Taxiway Edge LED (ETEL) Light

Document No. 96A0297

Issued: September 3, 2002

Rev. H: May 27, 2010

Patented: Patent No.: US 7,083,315 B2

ETL Certified to FAA Specification
AC 150/5345-46B

ADB Airfield Solutions

P.O. Box 30829
977 Gahanna Parkway
Columbus, OH 43230

Tel: (614) 861-1304
Fax: (614) 864-2069

Copyright © 2003 by ADB Airfield Solutions, LLC. All rights reserved.

Record of Changes

Page	Rev	Description	EC No.	Checked	Approved	Date
	A	Released new manual.	00921	DR	GM	9/3/02
Title page	B	Changed manual number from 96A00297 to 96A0297.	00959	JY	WT	10/7/02
3-5, 3-6	C	Added a caution statement and changed procedural steps in the subsection <i>Base Mounting</i> .	00969	JY	WT	10/31/02
6-2, 7-2	D	Updated ordering code in Figure 7-1. Added procedure for replacing existing fixture with LED fixture.	01028	JY	WT	2/24/03
All pages	E	Updated Figures 2-1, 3-1, 3-2, 3-4, and 7-2 by adding flag holder hole. Incorporated manual review revisions.	01045	DR	ER	3/13/03
7-2, 7-3, 7-4,7-6	F	Added Blue Column Option to order code and Parts lists	01125	WT	WT	8/4/03
Cover, pg 2-1	G	Added Patent No.	1674	WT	WT	9/7/06
	H	Changes for ADB logo				5/27/10

Table of Contents

Record of Changes.....	ii
Table of Contents.....	iii
Warranties.....	v

Safety

Section 1 Safety.....	1-1
1. Safety	1-1
2. Safety Symbols.....	1-1
3. Qualified Personnel.....	1-2
4. Intended Use	1-2
5. Installation.....	1-3
6. Operation.....	1-4
7. Action in the Event of a System or Component Malfunction	1-4
8. Maintenance and Repair.....	1-4

Description

Section 2 Description	2-1
1. Introduction.....	2-1
2. L-861T Elevated Light Fixture: Required Equipment	2-2
3. Specifications	2-3
Input	2-3
Expected LED Life.....	2-3
Light Source	2-3
Environmental Operating Conditions	2-3
Weight	2-4
Photometric Data.....	2-4

Installation

Section 3 Installation.....	3-1
1. Introduction.....	3-1
2. Unpacking	3-1
3. Placement	3-1
4. Installation.....	3-2
Base Mounting	3-2
Stake Mounting	3-7

Maintenance

Section 4 Maintenance	4-1
1. Introduction.....	4-1
2. Maintenance Schedule.....	4-1
3. Assembly Instructions	4-2

Troubleshooting

Section 5 Troubleshooting	5-1
1. Introduction.....	5-1
2. Troubleshooting Procedures.....	5-1

Repair

Section 6 Repair 6-1
 1. Introduction 6-1
 2. LED Electronic Module Replacement 6-1
 3. Replacing Existing Fixture with L-861T LED Fixture 6-2
 Replacing Existing Light Fixture and Transformer 6-2
 Replacing Only Light Fixture 6-2

Parts

Section 7 Parts 7-1
 1. Introduction 7-1
 2. Using the Illustrated Parts List 7-1
 3. L-861T LED Light Fixture Ordering Code 7-2
 4. L-861T Light Fixture Parts List 7-3
 5. L-861T Optional Stake Assembly Parts List 7-5
 6. Optional Parts 7-6
 7. Recommended Spare Parts 7-6

List of Figures

Figure 2-1 L-861T Elevated Taxiway Edge Light 2-1
 Figure 3-1 Base Mounting 3-3
 Figure 3-2 L-861T Elevated Light Fixture Installation 3-5
 Figure 3-3 Stake Assembly 3-7
 Figure 3-4 Stake Mounting 3-8
 Figure 7-1 L-861T Light Fixture Ordering Code 7-2
 Figure 7-2 L-861T Light Fixture 7-4
 Figure 7-3 Stake Assembly 7-5

List of Tables

Table 2-1 Mounting Columns 2-2
 Table 2-2 Required Equipment Supplied 2-2
 Table 2-3 Required Equipment Not Supplied 2-3
 Table 2-4 Isolation Transformers 2-3
 Table 2-5 Light Fixture Weight 2-4
 Table 2-6 Photometric Data 2-4
 Table 4-1 L-861T Light Fixture Maintenance 4-1

Warranties

WARRANTY FOR GOODS AND SERVICES: Seller warrants, to the extent to which any of the same may be applicable, that (a) on the date of shipment the goods are of the kind and quality described herein and are free of non-conformities in workmanship and material, (b) the engineering services performed by it will be performed in accordance with generally accepted professional standards, (c) any specialized tools, equipment and instruments for the use of which a charge is made to the Buyer shall be adequate for the work to be performed and (d) any replacement or other parts furnished by it or any work done by it on the Buyer's equipment or both shall be free of defects in workmanship and materials. This warranty does not apply to goods delivered by Seller but manufactured by others.

Buyer's exclusive remedy for any failure of the goods or services to conform to any of the applicable warranties shall be to have Seller re-perform services, repair or replace (at Seller's option) the nonconforming item and any affected part of the goods provided by Seller. Seller's obligation to re-perform services or to repair or replace goods shall be in effect for a period of one (1) year from initial operation of the goods or completion of Services but not more than eighteen (18) months from Seller's shipment of the goods. Seller shall correct any failure to conform to any of the applicable foregoing warranties of which it is notified in writing within that period of time specified.

Repaired and replacement parts and repair services shall be warranted for the remainder of the original period of notification set forth above, but in no event less than 12 months from repair or replacement. In the case of any other breach of the foregoing warranty, Seller shall furnish engineering services or specialized tools, equipment and instruments, to the same extent as on the original work. Buyer shall grant Seller access to the goods or services at all reasonable times in order for Seller to determine any nonconformity in the goods or services. It is understood and agreed that, unless otherwise agreed to in writing by Seller, Seller assumes no responsibility with respect to the suitability of the Buyer's equipment or any latent defects in the same. In no event shall Seller be responsible for providing working access to the defect, including the removal, disassembly, replacement or reinstallation of any equipment, materials or structures to the extent necessary to permit Seller to perform its warranty obligations, or transportation costs to and from the Seller factory or repair facility, or for damage to equipment components or parts resulting in whole or in part from improper maintenance or operation or from their deteriorated condition. Seller shall have the right of disposal of items replaced by it. If Seller is unable or unwilling to repair or replace, or if repair or replacement does not remedy the nonconformity, Seller and Buyer shall negotiate an equitable adjustment in the contract price, which may include a full refund of the contract price for the nonconforming goods or services. All warranty work shall be performed in a single shift straight time basis Monday through Friday. In the event the Buyer requires correction of warranty items on an overtime schedule, the premium portion of such overtime shall be for the Buyer's account.

THIS IS SELLER'S SOLE GUARANTEE AND WARRANTY WITH RESPECT TO THE GOODS AND SERVICES. THERE ARE NO OTHER EXPRESS OR IMPLIED WARRANTIES OR WARRANTIES OF FITNESS FOR ANY PARTICULAR PURPOSE OR ANY IMPLIED WARRANTIES OF FITNESS FOR ANY PARTICULAR PURPOSE OR ANY IMPLIED WARRANTIES OTHER THAN THOSE MADE EXPRESSLY HEREIN. ALL SUCH WARRANTIES ARE EXPRESSLY DISCLAIMED.

Disclaimers

This manual could contain technical inaccuracies or typographical errors. ADB Airfield Solutions reserves the right to revise this manual from time to time in the contents thereof without obligation of ADB Airfield Solutions to notify any person of such revision or change.

Details and values given in this manual are average values and have been compiled with care. They are not binding, however, and ADB Airfield Solutions disclaims any liability for damages or detriments suffered as a result of reliance on the information given herein or the use of products, processes or equipment to which this manual refers. No warranty is made that the use of the information or of the products, processes or equipment to which this manual refers will not infringe any third party's patents or rights. The information given does not release the buyer from making their own experiments and tests.

Section 1

Safety

1. Safety

This section contains general safety instructions for using your ADB Airfield Solutions equipment. Some safety instructions may not apply to the equipment in this manual. Task- and equipment-specific warnings are included in other sections of this manual where appropriate. Note all warnings and follow all instructions carefully. Failure to do so may result in personal injury, death, or property damage.

To use this equipment safely,

- refer to the FAA Advisory Circular AC 150/5340-26, *Maintenance of Airport Visual Aids Facilities*, for instructions on safety precautions.
- observe all safety regulations. To avoid injuries, always remove power prior to making any wire connections and touching any parts. Refer to FAA Advisory Circular AC 150/5340-26.
- read and become familiar with the general safety instructions provided in this section of the manual before installing, operating, maintaining, or repairing this equipment.
- read and carefully follow the instructions given throughout this manual for performing specific tasks and working with specific equipment.
- store this manual within easy reach of personnel installing, operating, maintaining, or repairing this equipment.
- follow all applicable safety procedures required by your company, industry standards, and government or other regulatory agencies.
- obtain and read Material Safety Data Sheets (MSDS) for all materials used.

2. Safety Symbols

Become familiar with the safety symbols presented in this section. These symbols will alert you to safety hazards and conditions that may result in personal injury, death, or property and equipment damage.



WARNING: Failure to observe this warning may result in personal injury, death, or equipment damage.

2. Safety Symbols (*contd.*)



WARNING: Risk of electrical shock. Failure to observe this warning may result in personal injury, death, or equipment damage.



WARNING: Disconnect equipment from line voltage. Failure to observe this warning may result in personal injury, death, or equipment damage.



WARNING: Wear safety goggles. Failure to observe may result in serious injury.



CAUTION: Failure to observe may result in equipment damage.

3. Qualified Personnel

The term *qualified personnel* is defined here as individuals who thoroughly understand the equipment and its safe operation, maintenance, and repair. Qualified personnel are physically capable of performing the required tasks, familiar with all relevant safety rules and regulations and have been trained to safely install, operate, maintain, and repair the equipment. It is the responsibility of the company operating this equipment to see that its personnel meet these requirements.

4. Intended Use



WARNING: Use of this equipment in ways other than described in this manual may result in personal injury, death, or property and equipment damage. Use this equipment only as described in this manual.

ADB Airfield Solutions cannot be responsible for injuries or damages resulting from nonstandard, unintended applications of its equipment. This equipment is designed and intended only for the purpose described in this manual. Uses not described in this manual are considered unintended uses and may result in serious personal injury, death, or property damage. Unintended uses may result from taking the following actions:

- making changes to equipment that have not been recommended or described in this manual or using parts that are not genuine ADB Airfield Solutions replacement parts
- failing to make sure that auxiliary equipment complies with approval agency requirements, local codes, and all applicable safety standards

4. Intended Use(*contd.*)

- using materials or auxiliary equipment that are inappropriate or incompatible with your ADB Airfield Solutions equipment
- allowing unqualified personnel to perform any task

5. Installation

Read the installation section of all system component manuals before installing your equipment. A thorough understanding of system components and their requirements will help you install the system safely and efficiently.



WARNING: Failure to follow these safety procedures can result in personal injury or death.

- Allow only qualified personnel to install ADB Airfield Solutions and auxiliary equipment. Use only approved equipment. Using unapproved equipment in an approved system may void agency approvals.
- Make sure all equipment is rated and approved for the environment in which you are using it.
- Follow all instructions for installing components and accessories.
- Install all electrical connections to local code.
- Use only electrical wire of sufficient gauge and insulation to handle the rated current demand. All wiring must meet local codes.
- Route electrical wiring along a protected path. Make sure they will not be damaged by moving equipment.
- Protect components from damage, wear, and harsh environment conditions.
- Allow ample room for maintenance, panel accessibility, and cover removal.
- Protect equipment with safety devices as specified by applicable safety regulations.
- If safety devices must be removed for installation, install them immediately after the work is completed and check them for proper functioning.

6. Operation

Only qualified personnel, physically capable of operating the equipment and with no impairments in their judgment or reaction times, should operate this equipment.

Read all system component manuals before operating this equipment. A thorough understanding of system components and their operation will help you operate the system safely and efficiently.

- Before starting this equipment, check all safety interlocks, fire-detection systems, and protective devices such as panels and covers. Make sure all devices are fully functional. Do not operate the system if these devices are not working properly. Do not deactivate or bypass automatic safety interlocks or locked-out electrical disconnects or pneumatic valves.
- Never operate equipment with a known malfunction.
- Do not attempt to operate or service electrical equipment if standing water is present.
- Use this equipment only in the environments for which it is rated. Do not operate this equipment in humid, flammable, or explosive environments unless it has been rated for safe operation in these environments.
- Never touch exposed electrical connections on equipment while the power is ON.

7. Action in the Event of a System or Component Malfunction

Do not operate a system that contains malfunctioning components. If a component malfunctions, turn the system OFF immediately.

- Disconnect and lock out electrical power.
- Allow only qualified personnel to make repairs. Repair or replace the malfunctioning component according to instructions provided in its manual.

8. Maintenance and Repair

Allow only qualified personnel to perform maintenance, troubleshooting, and repair tasks. Only persons who are properly trained and familiar with ADB Airfield Solutions equipment are permitted to service this equipment.

- Always use safety devices when working on this equipment.
- Follow the recommended maintenance procedures in your equipment manuals.
- Do not service or adjust any equipment unless another person trained in first aid and CPR is present.

8. Maintenance and Repair*(contd.)*

- Connect all disconnected equipment ground cables and wires after servicing equipment. Ground all conductive equipment.
- Use only approved ADB Airfield Solutions replacement parts. Using unapproved parts or making unapproved modifications to equipment may void agency approvals and create safety hazards.
- Check interlock systems periodically to ensure their effectiveness.
- Do not attempt to service electrical equipment if standing water is present. Use caution when servicing electrical equipment in a high-humidity environment
- Use tools with insulated handles when working with electrical equipment.

Section 2

Description

1. Introduction

See Figure 2-1. This section describes the ADB Airfield Solutions *Signature Series*™ patented L-861T elevated taxiway edge LED (ETEL) Patent No: US 7,083,315 B2. The L-861T elevated taxiway edge LED light is used to delineate the edges of airport taxiways, holding bays, and aprons. These elevated lights are ETL certified according to FAA specification AC 150/5345-46B, and FAA LED specifications.

NOTE: *Signature Series* is a trademark of ADB Airfield Solutions.

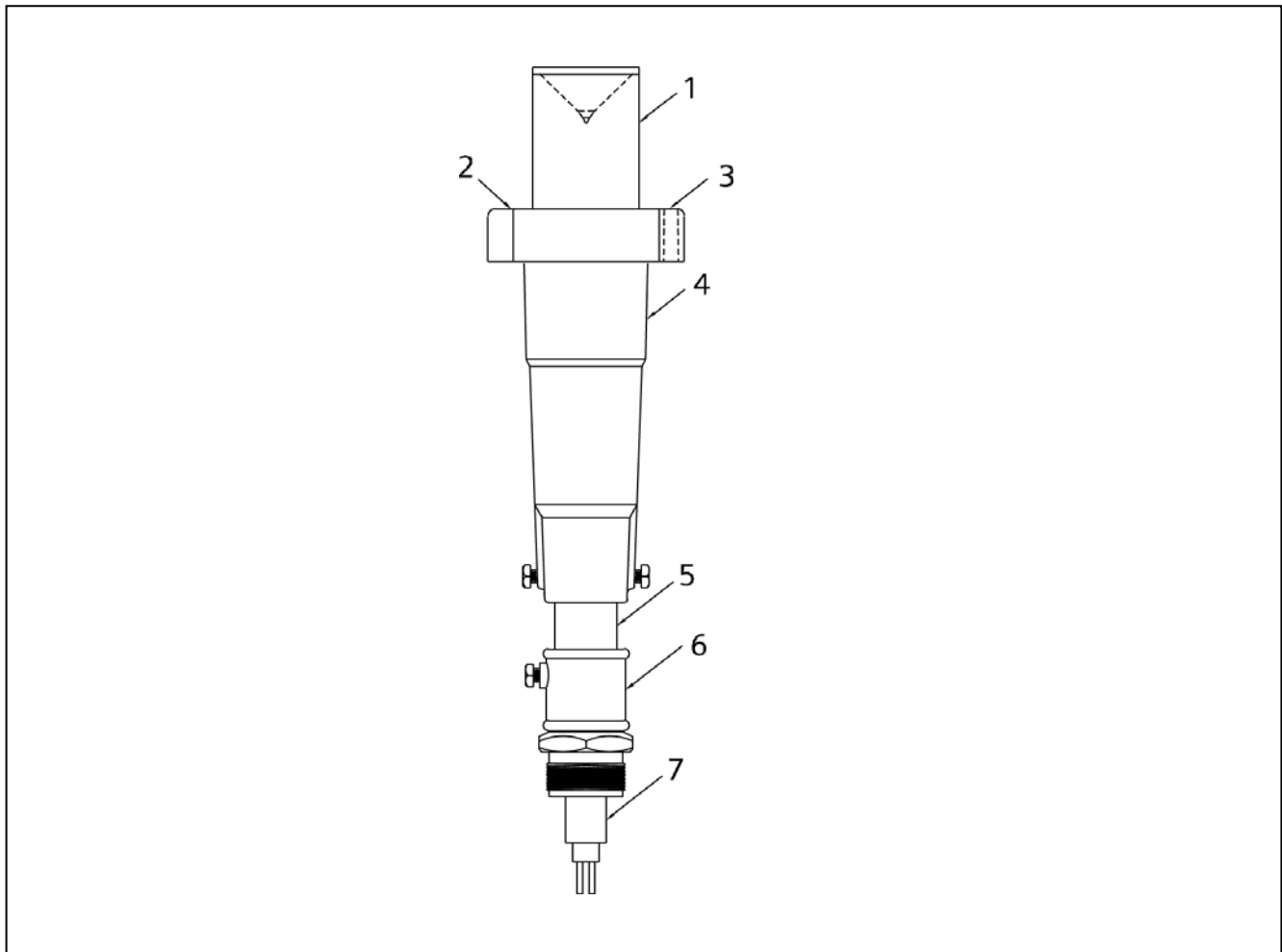

Figure 2-1 L-861T Elevated Taxiway Edge Light

- | | | |
|---------------------------|-----------------------|------------|
| 1. Optical Column | 4. Housing | 7. Cordset |
| 2. Locking Ring | 5. Column | |
| 3. Hole for Optional Flag | 6. Frangible Coupling | |

1.

1. Introduction (*contd.*)

See Figure 2-1. The L-861T elevated light fixtures consist of the following physical elements:

- Optical column (1)
- Locking ring (2)
- Housing (4)
- Column (5)
- Frangible coupling (6)
- Cordset (7)
- LED assembly (electronic module)
(See Figure 3-1, Item 9)

The fixtures can be stake mounted on a 30-inch galvanized steel stake. The fixtures can also be mounted on a base plate for a 12- or 16-inch diameter L-867 base with 1-1/2–12 NPS or a special 2 NPT frangible reducer coupling for an existing installation that has 2-inch NPT hubs in the base plate. Base mounting is recommended because maintenance is easier to perform. Stake-mounted lights require transformers, cables, and connectors that are designed for direct earth burial.

The mounting column is available in three lengths. Refer to Table 2-1.

NOTE: The measurements in Table 2-1 are taken from the grade to the top of the light fixture.

Table 2-1 Mounting Columns

Type	Height in. (mm)
Standard (FAA minimum)	14 (355.6)
Standard	24 (610)
Standard (FAA maximum)	30 (762)

2. L-861T Elevated Light Fixture: Required Equipment

Refer to Table 2-2 for required equipment that is supplied. Refer to Table 2-3 for required equipment that is not supplied. Refer to the *Parts* section for part numbers.

Table 2-2 Required Equipment Supplied

Description	Quantity
L-861T light fixture (with optical column, frangible fitting, LED module, and L-823 cordset)	1
Instruction manual	1

2. L-861T Elevated Light Fixture: Required Equipment *(contd.)*

Table 2-3 Required Equipment Not Supplied

Description	Quantity
Torque wrench (0 to 200 inch-pounds)	1 (if required)
Loctite number 243 or equivalent	As required
L-867 base plate assembly with 1-1/2-12 NPS with gasket (for 12- or 16-inch diameter L-867 base) when fixture is base mounted	1 (if required)
Stake assembly (30-inch galvanized steel) when fixture is stake mounted	1 (if required)
Isolation transformer for series circuit (Refer to Table 2-4 for appropriate transformers.)	1 (if required)

Table 2-4 Isolation Transformers

For a...	Then use this isolation transformer...	Note
6.6 A series circuit	L-830-1 (6.6 A/6.6 A, 45 W) for 60 Hz L-831-1 (6.6 A/6.6 A, 45 W) for 50 Hz	A
20 A/6.6 A series circuit	L-830-2 (20 A/6.6 A, 45 W) for 60 Hz L-832-2 (20 A/6.6 A, 45 W) for 50 Hz	
NOTE A: To match the fixture load for optimal efficiency, use the 10 W, 6.6 A/6.6 A transformer (Part Number 35A0578).		

3. Specifications

This subsection provides specifications for the L-861T light fixtures.

Input

2.8-6.6 A (3-Step or 5-Step)

Expected LED Life

56,000 hours in high intensity conditions.
More than 150,000 hours in actual operating conditions.

Light Source

One watt high lumen density (brightness) LED

Environmental Operating Conditions

The L-861T light fixture is designed to operate under the conditions presented below for temperature, wind, altitude, and relative humidity.

Temperature

-55 to +55 °C (-67 to +131 °F)

Wind

Velocities up to 350 mph (560 kph)

Altitude

Sea level to 10,000 feet (3000 m)

Relative Humidity

Up to 100 %

Weight

Refer to Table 2-5.

Table 2-5 Light Fixture Weight

Assembled Fixture	Fixture Weight
14-Inch overall height	5 lb (2.27 kg)
24-Inch overall height	6.25 lb (2.84 kg)
30-Inch overall height	7 lb (3.18 kg)

Photometric Data

This subsection provides photometric data for the L-861T light fixture.
Refer to Table 2-6.

Table 2-6 Photometric Data

Color	Light Source	Measured Peak Intensity (candelas)	
		5 Degrees Vertical	FAA Minimum
Blue	1 light emitting diode	2.3 minimum	2

Section 3

Installation



WARNING: Allow only qualified personnel to perform the following tasks. Observe and follow the safety instructions in this document and all other related documentation.

1. Introduction

This section provides instructions for installing the L-861 medium intensity elevated light fixture. Refer to the airport project plans and specifications for the specific installation instructions.

2. Unpacking

The equipment is shipped ready for installation. Handle equipment very carefully to prevent component damage. Unpack the carton upon receipt and check the contents and their condition. Note any exterior damage to the carton that might lead to detection of equipment damage.

If you note any damage to any equipment, file a claim with the carrier immediately. The carrier may need to inspect the equipment.

3. Placement

This subsection describes the placement of the L-861T light fixtures. Follow the guidelines below, along with FAA specification AC 150/5340-24 and site plans, when placing the L-861T light fixture.

- The L-861T light fixture is normally positioned a maximum of 10 feet (3.048 m) off the edge of the hard surface of the taxiway, and in a straight line with all other light fixtures on the same side of the runway.
- The longitudinal spacing of the light fixtures should not exceed 200 feet (60.96 m) to define the lateral limits of the taxiing paths. The longitudinal spacing of the lights is influenced by the physical layout of the taxiways.
- Closer spacing of the lights should be provided on short taxiway sections, curves, and entrances to taxiways from runways or aprons.

4. Installation

This subsection provides installation instructions for the L-861T light fixtures.

Base Mounting

L-861T light fixtures can be mounted on an L-867 base mated with a base plate with a diameter and bolt-hole corresponding to either a 12-inch- (304.8 mm-) diameter L-867B base or a 16-inch- (406.4 mm-) diameter L-867D base. The base plate is designed to receive a frangible coupling using a female thread. A gasket is used with the base plate to form a watertight seal between the base plate and the L-867 base.

NOTE: Install the base according to appropriate FAA specifications and site plans.

Base Mounting (*contd.*)

To install the base, perform the following procedure:

1. See Figure 3-1. Install the L-867 base (2) on undisturbed soil. If the soil is unsuitable, remove soil to an adequate depth and replace with compacted acceptable material.

NOTE: In closed duct systems, install in soil conditions with good drainage. Use light bases having a drain hole to prevent water accumulation.

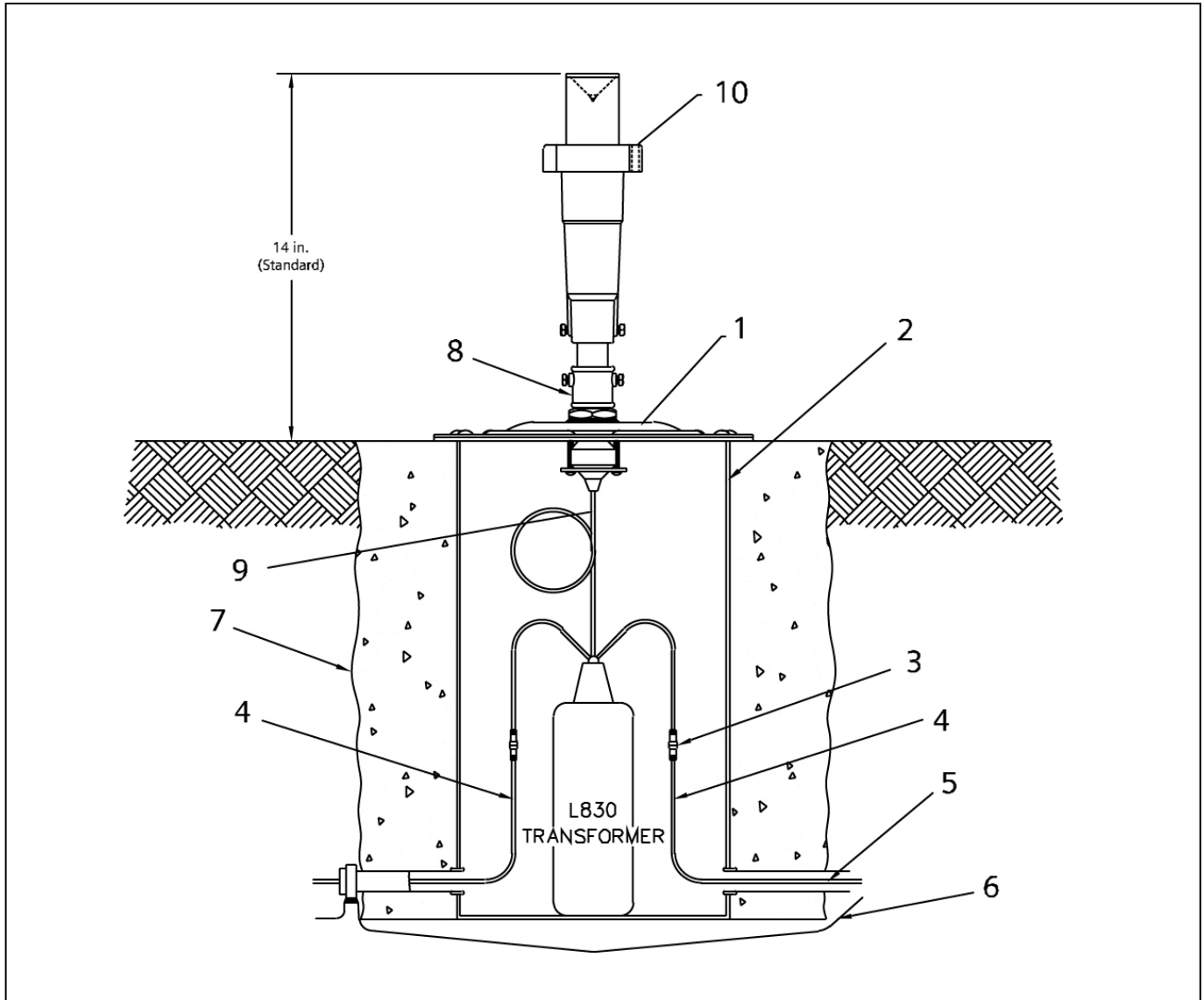

Figure 3-1 Base Mounting

- | | | |
|----------------------------|---|--|
| 1. L-867 Base Plate | 4. Two-foot Slack for Connections (Minimum) | 7. Four-Inches Concrete Backfill Recommended |
| 2. L-867 Base | 5. 5 KV, L-824 Cable | 8. Frangible Coupling and Disconnect Plug |
| 3. L-823 Primary Connector | 6. Optional Bare Copper Counterpoise Wire | 9. L-823 Secondary Connector |
| | | 10. Hole for Flag |

Base Mounting (*contd.*)

2. Orient the cable entrance hubs of the base in the proper directions.
3. Level the light base so that the mounting flange surface is level with the finished grade.
4. With the base at the proper orientation and held at proper elevation, place approximately 4 inches (101.6 mm) of concrete backfill (7) around the outside base.

NOTE: If the concrete backfill is omitted, the earth backfill must be compacted to maintain proper elevation and orientation of the base.

5. Slope the top of the concrete away from the flange portion of the base so the sloped outer edges of the concrete are at surface grade.
6. To install the LED light fixture, connect the primary power line to the appropriate isolation transformer. Refer to Table 2-4.

NOTE: Use a brick to raise the transformer about 3 inches above the bottom surface of the L-867 base to avoid the possibility of the transformer being partially immersed in water in case water accumulates above the level of the ducts or pipes.

7. After you have connected the transformer, check the continuity of the series loop.
8. Wrap the connector joints in the primary circuit with at least one layer of rubber or synthetic rubber tape and one layer of plastic tape one-half lapped, extending at least 1-1/2 inches (3.81 cm) on each side of the joint.
9. Clamp the female secondary plug from the isolation transformer to the L-867 base plate fitting.
10. Bolt the base plate (1) with the base plate gasket to the L-867 base using six 3/8-16 stainless steel bolts. Apply a drop of Loctite number 243 to each bolt thread, and use a torque wrench to torque bolts down to 100/110 inch-pounds (11.3 Nt-m).

11. Connect the male L-823 plug (Figure 3-1, Item 3) from the light fixture to the female plug on the secondary lead of the isolation transformer by first loosening the frangible coupling hex screw (Figure 3-2, Item 7) until the coupling is free. Then retighten the hex screw finger-tight.

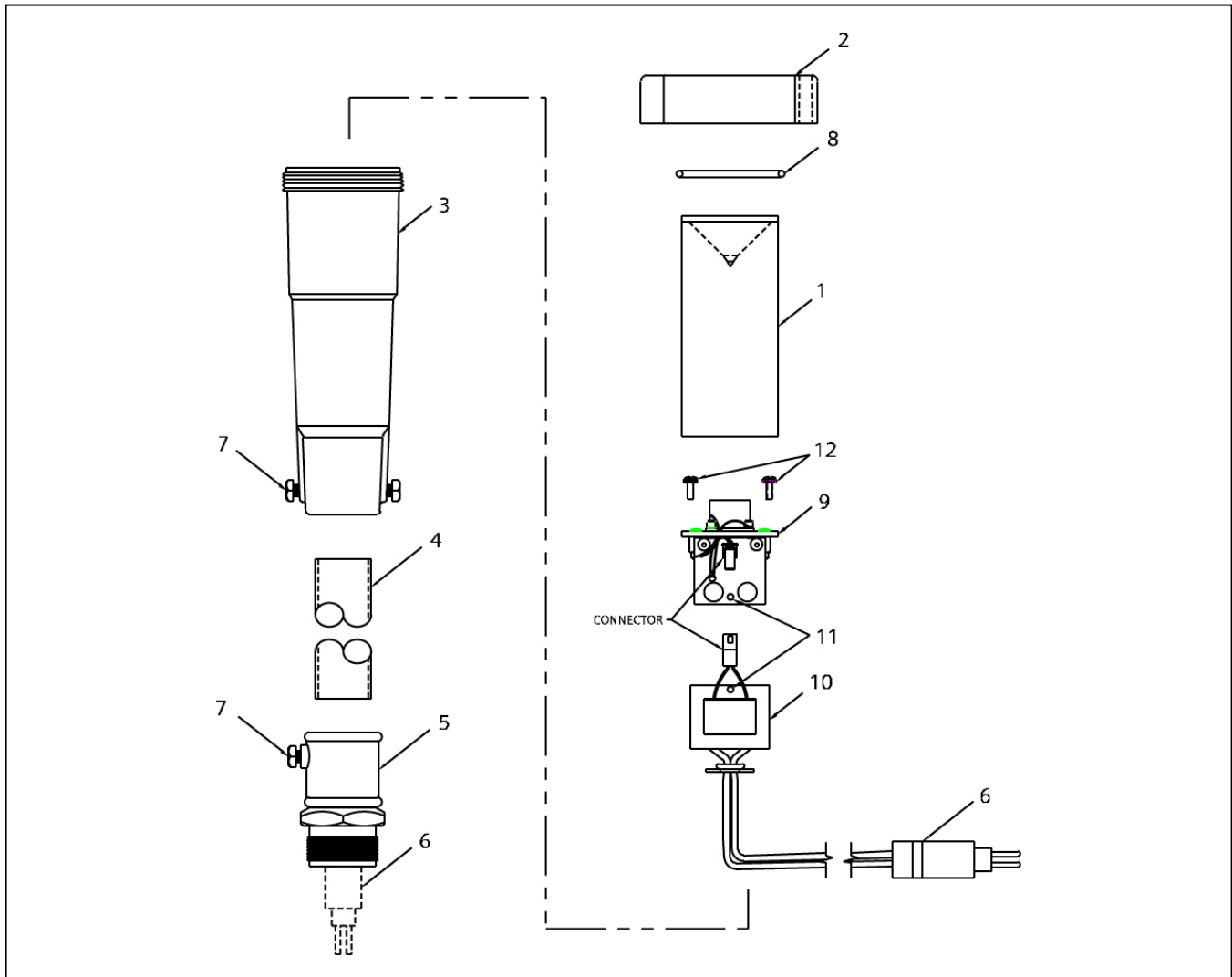

Figure 3-2 L-861T Elevated Light Fixture Installation

- | | | |
|-------------------|-----------------------|----------------------------------|
| 1. Optical Column | 5. Frangible Coupling | 9. Electronic Module (with LED) |
| 2. Locking Ring | 6. L-823 Cordset | 10. Transformer/Cordset Assembly |
| 3. Housing | 7. Hex Screw | 11. Nylon Wire Tie |
| 4. Column | 8. O-ring seal | 12. Self-Locking Screw |

Base Mounting (*contd.*)

12. Plug the L-823 into the mating isolation transformer secondary lead.
13. Loosen the hex screw on the coupling to free the coupling. Handscrew the coupling into the base plate hub. Finish tightening the coupling with a wrench.



CAUTION: Do not tighten the coupling if the coupling hex screw is still tight. Failure to follow these instructions will damage the L-823 connection to the transformer (Figure 3-2, Item 10).

14. Tighten the coupling screw that secures the column to the frangible coupling and the adjustable head.
15. Level the light fixture. Refer to *Light Fixture Leveling* in this section.

Light Fixture Leveling

Level the light fixture only after mounting it on the base.

To level the light fixture, perform the following procedure:

1. See Figure 3-2. Slightly loosen the three hex screws (7) in the bottom of the housing (3).
2. Place a level on top of the locking ring (2) and rotate housing (3) until level. Tighten the three hex screws (7) to lock in place.

Stake Mounting

Mount the column light fixtures on 30-inch (762-mm) galvanized steel stakes with a fitting attached to the top of each stake to receive the male thread of the frangible coupling. Stake mounting requires cables and connections that are designed for direct earth burial. Install according to appropriate FAA and local contractor specifications.

To mount the L-861T light fixture on a stake, perform the following procedure:

1. See Figure 3-3. Assemble the stake by attaching the stake hub (2) to the metal stake (5) using two 3/8–16 x 3/4-in. hex head screws (3) and 3/8-in. lockwashers (4).

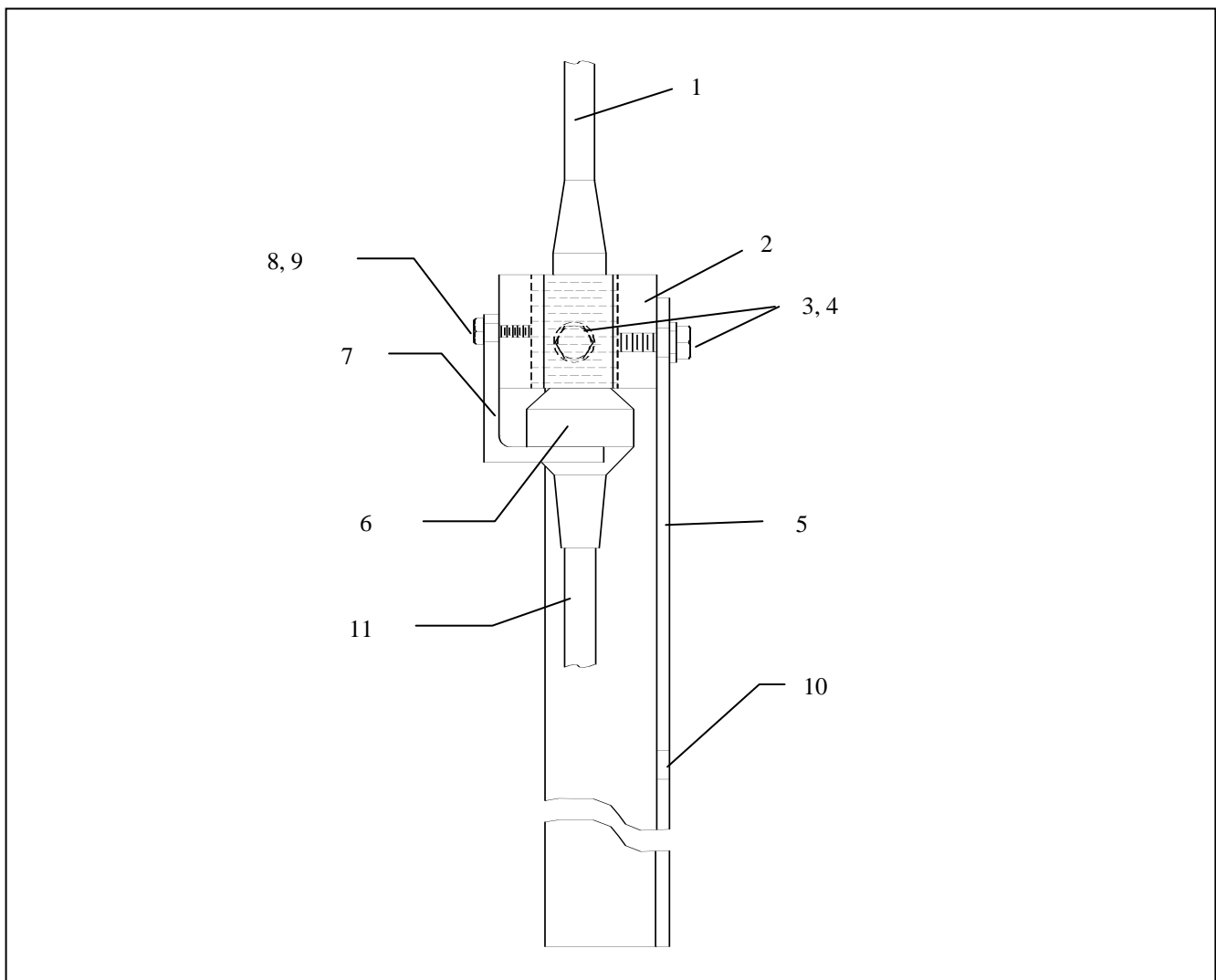

Figure 3-3 Stake Assembly

- | | | |
|--------------------|--------------------------------------|--------------------------------|
| 1. L-823 Male Plug | 5. Metal Stake | 9. Lockwasher |
| 2. Stake Hub | 6. Transformer Secondary Female Plug | 10. Grounding Screw Hole |
| 3. Hex Head Screw | 7. Cable Connector Support | 11. Transformer Secondary Lead |
| 4. Lockwasher | 8. Hex Head Screw | |

Stake Mounting (*contd.*)

- See Figure 3-4. Install the stake (4) in 6-inch- (152.4-mm-) diameter holes in the ground at a depth of 30 inches (762 mm) so that the mounting hub (8) of the stake is level.

NOTE: The top of the stake should be even with the ground within one degree of the vertical. In areas where frost may cause heaving, anchor the stake with concrete and use a permeable backfill material such as sand around the buried electrical components. Cover the top surface with an impervious material to reduce moisture penetration.



CAUTION: Do not drive stakes. Driving stakes may damage the stake and cause light fixture misalignment. Refer to FAA specification AC 150/5340-24.

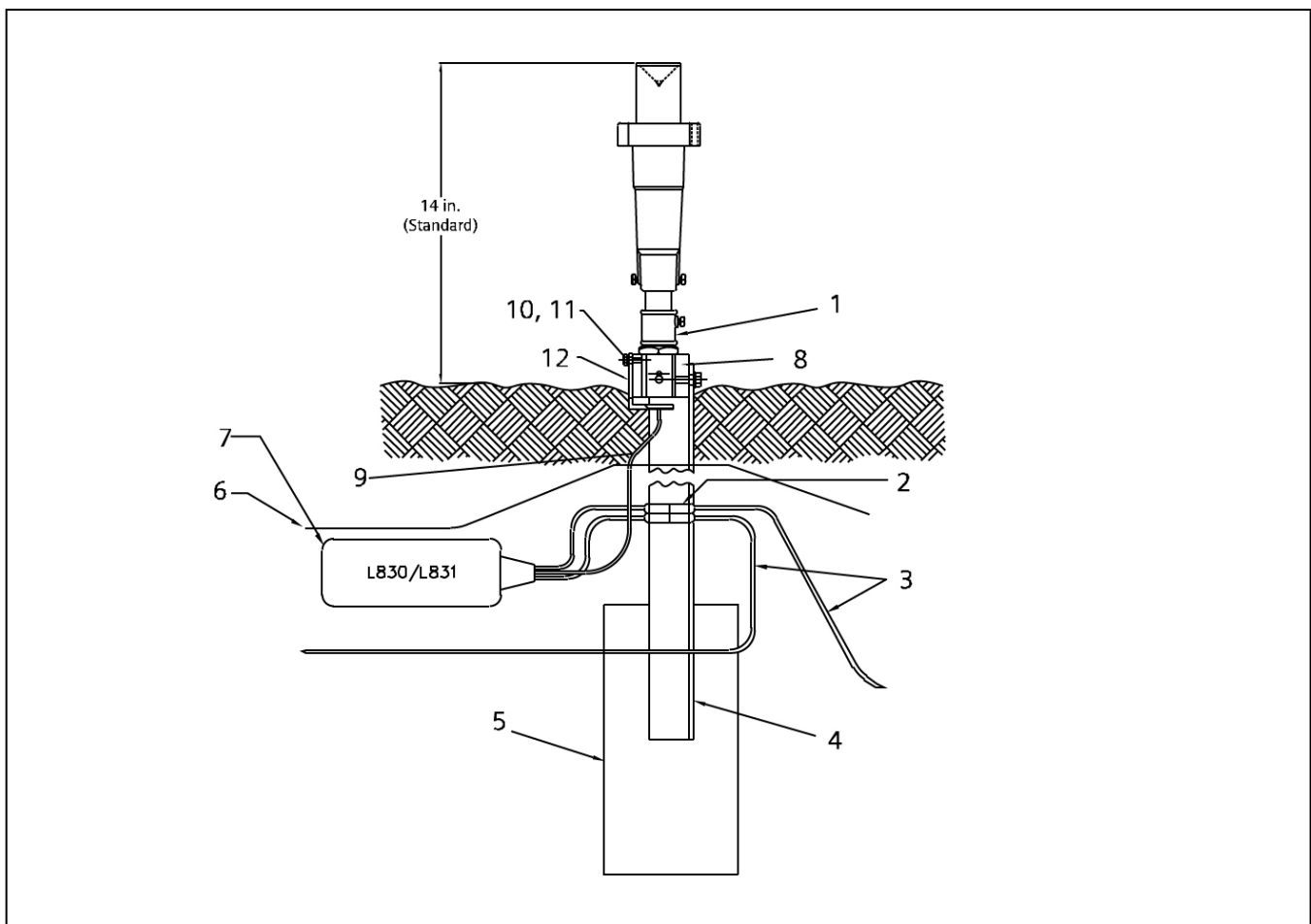

Figure 3-4 Stake Mounting

- | | |
|---|-------------------------------|
| 1. Frangible Coupling and Disconnect Plug | 7. Isolation Transformer |
| 2. Connectors | 8. Stake Hub |
| 3. 5 KV, L-824 Cable | 9. Transformer Secondary Plug |
| 4. Metal Stake (30 in.) | 10. Hex Head Screw |
| 5. Concrete Anchor (Recommended 6 x 6 x 12-in.) | 11. Lockwasher |
| 6. Optional Bare Copper Counterpoise Wire | 12. Cable Connector Support |

Stake Mounting (*contd.*)

3. Backfill around the stake with compacted earth passing a 1-inch (25.4 mm) sieve.

NOTE: Use a bubble level or carpenter's level to ensure the stake is vertical before backfilling around stake. Backfill with concrete (5) in case of unstable soil conditions.

4. Make electrical connections by installing the transformer primary cables (3) to the field circuit. Then insert the transformer secondary plug (9) in the cable connector support's forked tine and attach the cable connector support (12) to the stake hub (8) using 1/4-20 x 3/4-in. hex head screw (10) and 1/4-in. split lockwasher (11).

NOTE: The small hole at the lower end of the stake is provided for a counterpoise wire connection (6).

5. Install the light fixture on the stake.

Section 4

Maintenance

1. Introduction

This section provides maintenance information for the L-861T LED elevated light.

2. Maintenance Schedule

To keep the L-861T light fixtures operating efficiently, follow a preventive maintenance schedule. Refer to Table 4-1. Refer to FAA AC 150/5340-26 for more detailed information.

Table 4-1 L-861T Light Fixture Maintenance

Interval	Maintenance Task	Action
Weekly	Check for vegetation.	Remove vegetation. Use weed killer.
Monthly	Check for misaligned fixture.	Straighten, level, and align.
	Check for dirty optical column.	Clean with glass cleaner.
	Check for dirty frangible coupling weep holes (for stake-mounted fixtures only).	Clean weep holes.
Annually	Check for improper ground elevation.	Grade so frangible point is approximately 1 inch (25.4 mm) above ground elevation.
	Check for improper light elevation.	Maintain same elevation for all light fixtures.
	Check for corrosion present or paint loose or chipped.	Scrape and repaint.
	Check for chipped paint on exterior body and fixture.	Touch up paint as necessary.
		NOTE: The locking ring (Figure 2-1, Item 2) must remain blue in color. The blue color identifies the fixture as a taxiway fixture during daylight hours when power is off.
Unscheduled	Make prediction of heavy snowfall, if necessary.	Use red flags or sticks to mark the location of fixtures to facilitate snow removal and lessen the chance of damage to fixtures by snow removal equipment. Refer to the optional snow flag kit in <i>Optional Parts</i> in the <i>Parts</i> section.

3. Assembly Instructions

NOTE: The L-861T LED elevated light is assembled at the factory. Use the assembly instructions below when you need to assemble parts for repair or maintenance purposes.

To assemble parts, perform the following procedure:

1. See Figure 3-2. Attach the electronic module (9) to the cordset assembly (10) using the wire tie (11). Insert the assembled parts into the housing (3) and secure the self-locking screws (12).
2. Insert the optical column (1) into the housing (3) until it contacts the LED on the electronic module (9). Slide the O-ring seal (8) over the optical column and secure with the locking ring (2).

NOTE: Apply a light coat of anti-seize compound on the locking ring threads to make assembly and disassembly easier.



CAUTION: The optical column must mate to the top of the LED module. Failure of the optical column to touch the LED will create distorted photometric output.

3. Insert the cord through the column (4) and the frangible coupling (5) and secure both with the hex screws (7).

Section 5

Troubleshooting



WARNING: Allow only qualified personnel to perform the following tasks. Observe and follow the safety instructions in this document and all other related documentation.



WARNING: De-energize the circuit and lock out the circuit or regulator so that the circuit cannot be energized by remote means before attempting to service the fixture.

1. Introduction

This section contains troubleshooting information for the L-861T light fixture. This information covers only the most common problems that you may encounter. If you cannot solve the problem with the information given here, contact your local ADB Airfield Solutions representative for help.

2. Troubleshooting Procedures

Refer below for troubleshooting procedures for the L-861T LED elevated light.

Problem	Possible Cause	Corrective Action
1. LED not lighting	Defective electronic module	Replace the electronic module.
	Loose wire connections	Tighten wire connections.
	Deteriorated wire insulation	Replace wires.
	Moisture present in fixture	Open and dry the fixture. Inspect the optical column for cracks. Replace the electronic module, O-ring seal, and damaged optical column. Refer to the procedure under <i>LED Electronic Module Replacement</i> in the <i>Repair</i> section.
2. LED too dim	Dirty optical column	Clean the optical column.
	Service life of LED exceeded NOTE: Refer to <i>Expected LED Life</i> under <i>Specifications</i> in the <i>Description</i> section.	Replace the electronic module.

Section 6

Repair



WARNING: Allow only qualified personnel to perform the following tasks. Observe and follow the safety instructions in this document and all other related documentation.



WARNING: De-energize the circuit and lock out the circuit or regulator so that the circuit cannot be energized by remote means before attempting to service the fixture.

1. Introduction

This section provides instructions for repairing the L-861T LED light fixture. It includes replacing the L-861T LED electronic modules and replacing an existing fixture with an L-861 LED fixture.

2. LED Electronic Module Replacement

To replace an LED electronic module, perform the following procedure:

1. De-energize and lock out the circuit.
2. Remove the light fixture from the mounting base by performing the following procedure:
 - a. See Figure 3-1. Loosen the hex bolt (7) that attaches the frangible coupling (5) to the column (4).
 - b. Remove the frangible coupling from the base plate female thread.
 - c. Disconnect the L-823 plug of the light fixture from the female plug on the secondary lead of the isolation transformer.
3. Remove the locking ring (2) from the fixture by rotating it counterclockwise. Lift the optical column (1) from the housing (3).

NOTE: An O-ring seal (8) is provided with the replacement electronic module assembly. Remove and discard the old O-ring seal.

4. Remove the two screws (12) attaching the electronic module to the housing and remove the electronic module (9) and the cordset assembly (10). The L-823 cordset will fit through the clearance hole in the housing.
5. Separate the connectors between the electronic module and the cordset assembly.

2. LED Electronic Module Replacement (*contd.*)

6. Cut the nylon wire tie (11) to separate the electronic module.
7. Attach the replacement electronic module. Refer to the light fixture assembly procedure in *Assembly Instructions* in Section 3, *Installation*.
8. Level the light fixture. Refer to the fixture leveling procedure in *Light Fixture Leveling* in Section 3, *Installation*.

3. Replacing Existing Fixture with L-861T LED Fixture

This subsection provides two procedures for replacing the existing quartz or incandescent light fixture with the L-861T LED fixture:

- a) replacing existing light fixture and isolation transformer and
- b) replacing only the existing light fixture.

Replacing Existing Light Fixture and Transformer

The preferred method is replacing the existing light fixture and transformer. This method matches fixture load for optimal efficiency.

To replace the existing transformer and light fixture with the L-861T LED fixture and new 10 W isolation transformer, perform the following procedure:

1. Remove the existing L-861T light fixture and isolation transformer.
2. Install the new 10 W isolation transformer. Seal the primary connections according to local airport practice.
3. Plug the LED fixture into the new 10W, 6.6 A/6.6 A isolation transformer (Part Number 35A0578). Seal the isolation transformer secondary joint according to local airport practice.
4. Mount the new L-861T LED fixture.

Replacing Only Light Fixture

To replace only the existing light fixture with the L-861T LED fixture, perform the following procedure:

1. Remove the existing L-861T fixture.
2. Unplug the fixture from the isolation transformer.
3. Plug the LED fixture into the existing isolation transformer. Seal the isolation transformer secondary joint according to local airport practice.
4. Mount the new L-861T LED fixture.

Section 7

Parts

1. Introduction

To order parts, call ADB Airfield Solutions Customer Service or your local representative. Use this four-column parts list, and the accompanying illustration, to describe and locate parts correctly.

2. Using the Illustrated Parts List

This subsection describes how to use the illustrated parts list covered later in this section. It does not provide the actual parts list.

The Part Number column gives the ADB Airfield Solutions part number.

The Description column gives the part name, as well as its dimensions and other characteristics when appropriate. Indentions show the relationships between assemblies, subassemblies, and parts.

Part Number	Description	Quantity	Note
XXXXXXXX	Assembly	1	A
XXXXXXXX	Part	1	
XXXXXXXX	Part or Assembly		
XXXXXXXX	Assembly	1	
NOTE A			

The Quantity column contains the quantity required per unit, assembly, or subassembly. The code AR (As Required) is used if the part number is a bulk item ordered in quantities or if the quantity per assembly depends on the product version or model.

The Note column contains letters that refer to notes at the end of each parts list. Notes contain special ordering or product/part version information.

**3. L-861T LED Light Fixture
Ordering Code**

Figure 7-1 shows the ordering code for an L-861T LED light fixture.

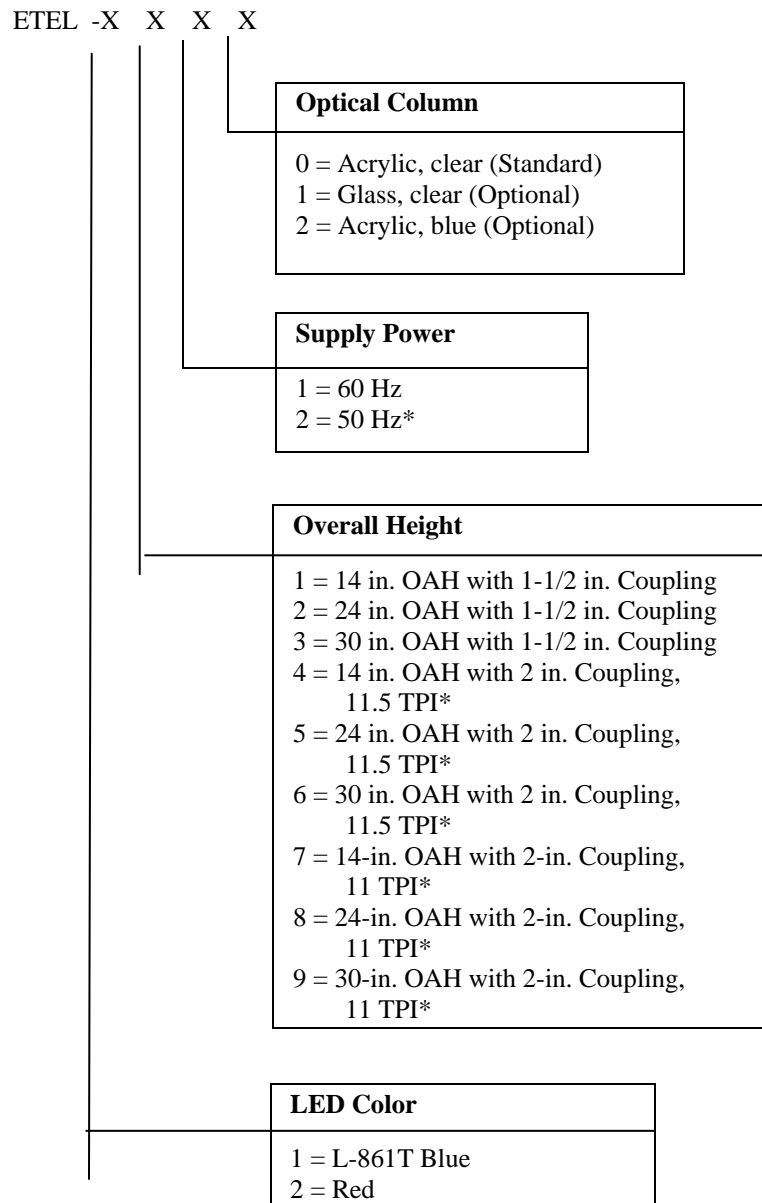

Figure 7-1 L-861T Light Fixture Ordering Code

*Not submitted for ETL testing.

4. L-861T Light Fixture Parts List

See Figure 7-2.

Part Number	Description	Quantity	Note
44A6227-50	Electronic module assembly, 50 Hz	1	
44A6227-60	Electronic module assembly, 60 Hz	1	
44A6233-1	Cordset assembly for 14 in. overall height	1	
44A6233-2	Cordset assembly for 24 in. overall height	1	
44A6233-3	Cordset assembly for 30 in. overall height	1	
61A0281	Frangible fitting for 2 in. coupling	1	
62A0007-3	Column for 14 in. overall height	1	
62A0007-13	Column for 24 in. overall height	1	
62A0007-19	Column for 30 in. overall height	1	
62B0073	Frangible coupling, 1-1/2 in.	1	
63A1020-1	Optical column, acrylic, clear (standard)	1	
63A1020-2	Optical column, glass, clear (optional)	1	
63A1020-3	Optical column, acrylic, blue (optional)	1	
63B0267-226	O-ring	1	
88A2146	Housing	1	
88A2147	Locking ring	1	

4. L-861T Light Fixture Parts

List (*contd.*)

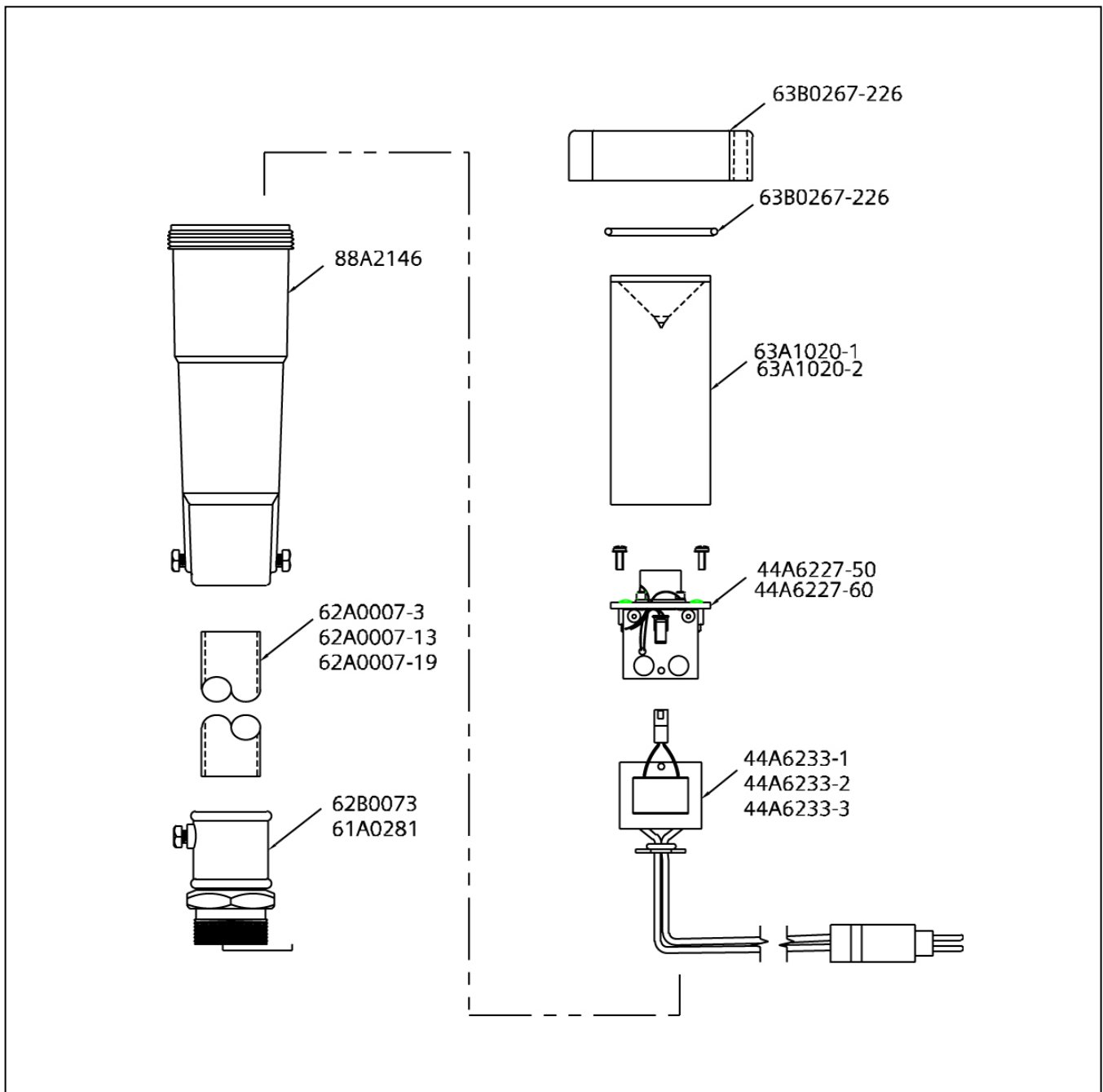

Figure 7-2 L-861T Light Fixture

5. L-861T Optional Stake Assembly Parts List

See Figure 7-5. The optional stake assembly part number is 44B0348.

Part Number	Description	Quantity	Note
62B0268-1	Stake hub	1	
64A0176-12	Hex head screw, 3/8-16 x 3/4 in.	1	
66A0026-29	Split lockwasher, 3/8 in.	1	
62B0284	Stake	1	
62B0269	Cable connector support	1	
64A0173-12	Hex head screw, 1/4-20 x 3/4 in.	1	
66A0026-24	Split lockwasher, 1/4 in.	1	

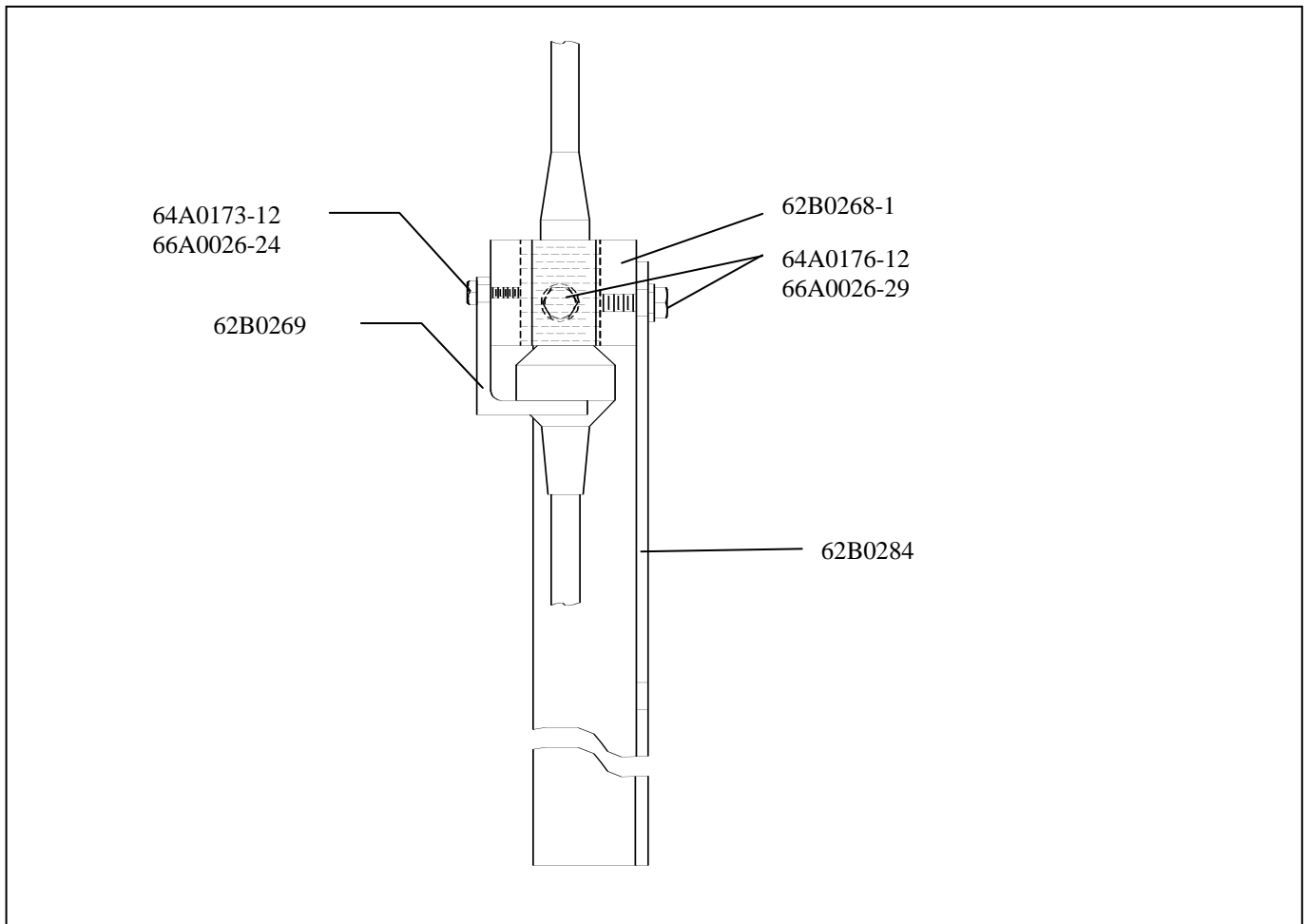

Figure 7-3 Stake Assembly

6. Optional Parts

Refer below for optional parts.

Part Number	Description	Quantity	Note
1935	12-inch-diameter base plate, 1.5–12 UNF tap	1	A
44B1070	Flag	1	B
NOTE A: Supplied with gasket. NOTE B: Special order.			

7. Recommended Spare Parts

See Figure 7-2.

Part Number	Description	Note
44A6227-50	Electronic module assembly, 50 Hz	
44A6227-60	Electronic module assembly, 60 Hz	
44A6233-1	Cordset for 14-inch OAH	
44A6233-2	Cordset for 24-inch OAH	
44A6233-3	Cordset for 30-inch OAH	
61A0281	Frangible 2 in. reducer coupling	
62A0007-3	Column for 14-inch OAH	
62A0007-13	Column for 24-inch OAH	
62A0007-19	Column for 30-inch OAH	
62B0073	Frangible coupling, 1-1/2 in.	
62B0461	Frangible coupling, 1-1/2 in., with slot	A
63A1020-1	Optical column, acrylic, clear (standard)	
63A1020-2	Optical column, glass, clear (optional)	
63A1020-3	Optical column, acrylic, blue (optional)	
63B0267-226	O-ring	
88A2146	LED module chamber	
88A2147	Optical column Locking ring	
NOTE A: Slot across threaded end allows easy access replacement of broken frangible coupling.		