

**3 TRASH ENCLOSURE**  
1/4"=1'-0"

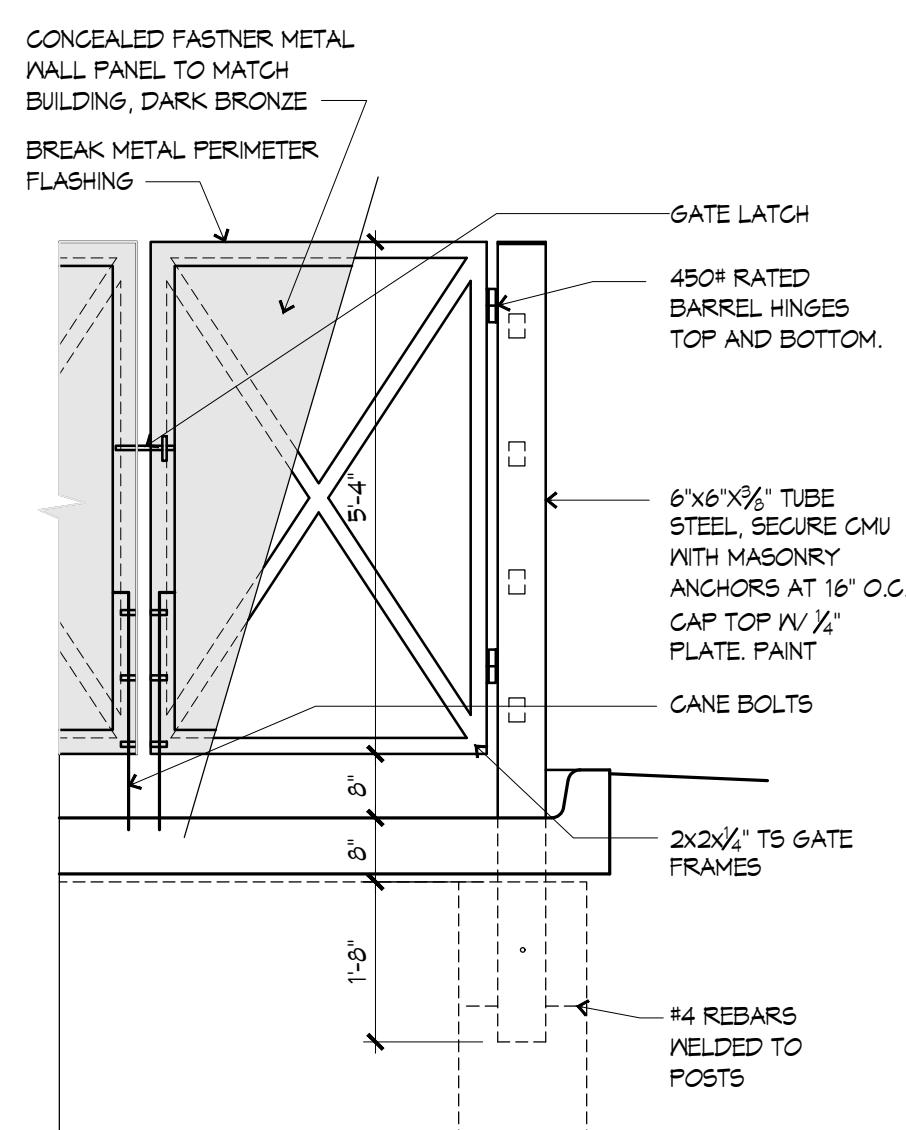

**4 GATE ELEVATION**  
1/2"=1'-0"

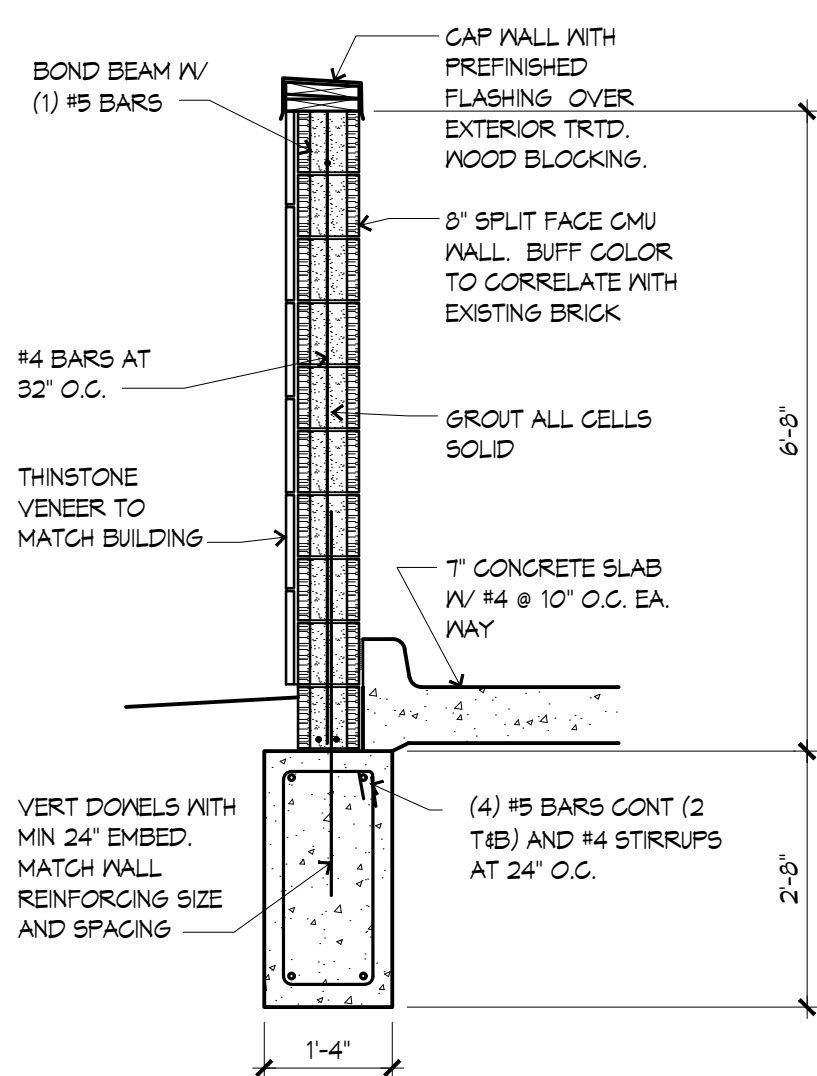

**5 TRASH SECTION**  
1/2"=1'-0"

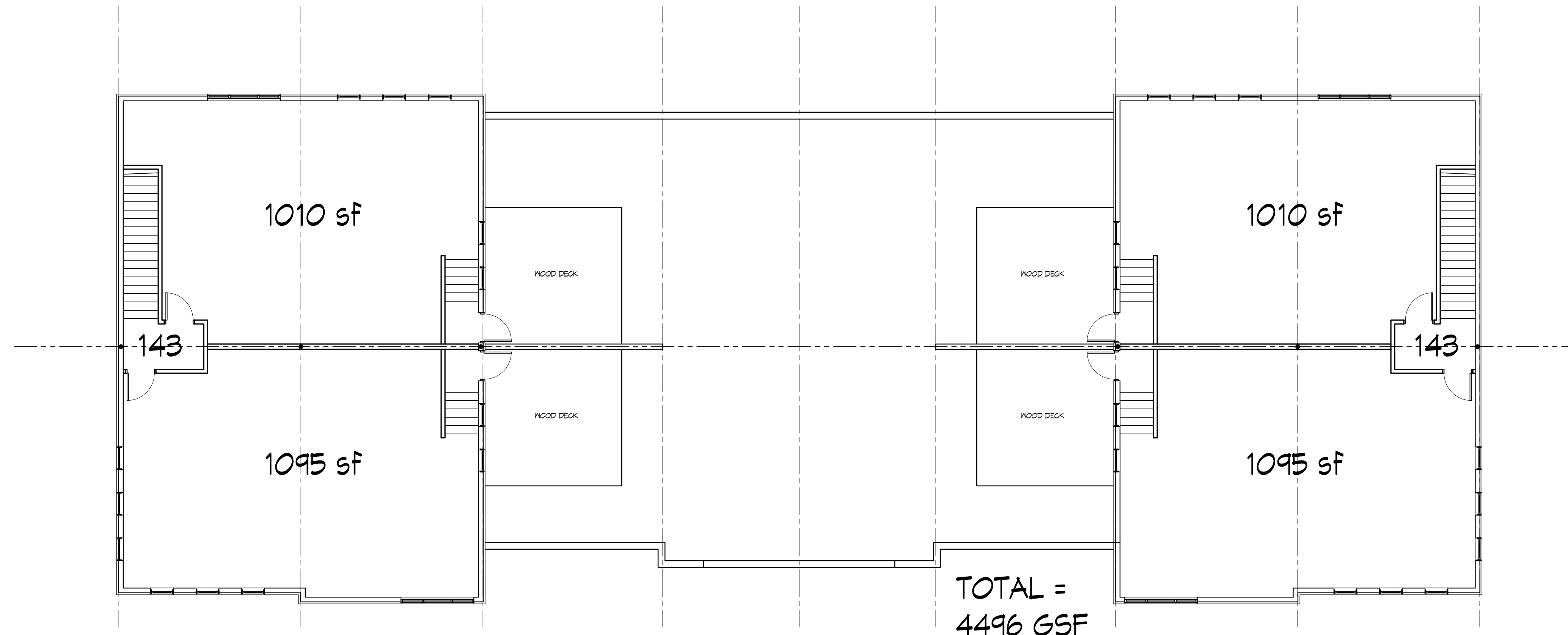

TOTAL =  
4496 GSF

**2 UPPER LEVEL SHELL PLAN**  
1/8"=1'-0"

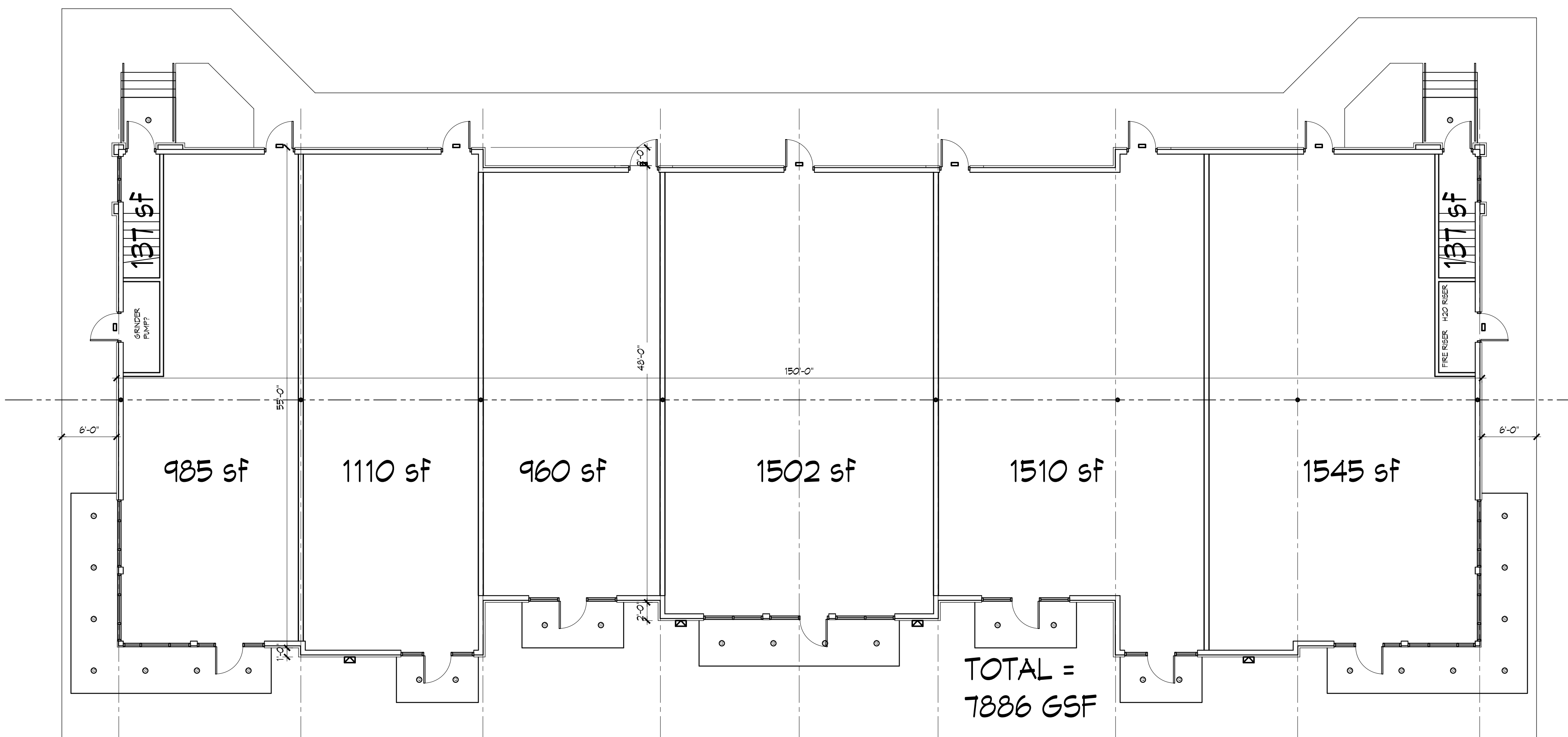

TOTAL =  
7886 GSF

**1 MAIN LEVEL SHELL PLAN**  
1/8"=1'-0"



**GUY GRONBERG ARCHITECTS, P.C.**  
113 S. 24th St.  
Lee's Summit, MO 64083  
Phone: 816.524.0870  
Fax: 816.524.9570

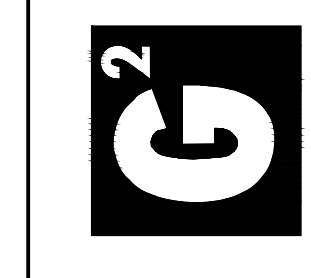

**DOUGLAS CORNER**  
LOT 1B, LEE'S SUMMIT, MISSOURI 64086

This drawing has been prepared as an instrument of service for the project or use for this project only. It is not to be used for any other project without the written consent of Guy Gronberg Architects, P.C. The client is responsible for the accuracy of the information provided and for the accuracy of the information received. GUY GRONBERG ARCHITECTS, P.C.

REV#	DATE	DESCRIPTION	PLANNING COMMENTS

DATE: 06-26-2010  
PROJECT# 18001

**A2**