

WINDOW SCHEDULE			
SIZE:	LOCATION:	SIZE:	LOCATION:
2-3060TG	DINING	WIDTH TO MATCH UNIT BELOW	DOOR TRANSOM
3060T	GREAT	2040G	STAIRS
3060T	BREAKFAST	2040G	STAIRS
CN24	KITCHEN	2040G	FOYER
2-3050	OFFICE	2040	STAIRS
3050	BASEMENT EGRESS	3-3060T	GREAT
3050	BEDROOM #2	3-3060T	BREAKFAST
2-3050G	BEDROOM #3	3020	BREAKFAST
3050G	BEDROOM #4	2640T	STAIRS
3050	MASTER	2660T	STAIRS
3050	MASTER	4040T	MASTER BATH
2-2050	MASTER		
2030	MASTER BATH		

LETTER NOTATIONS:
G-GRILLS T-TEMPERD A-ARCHED

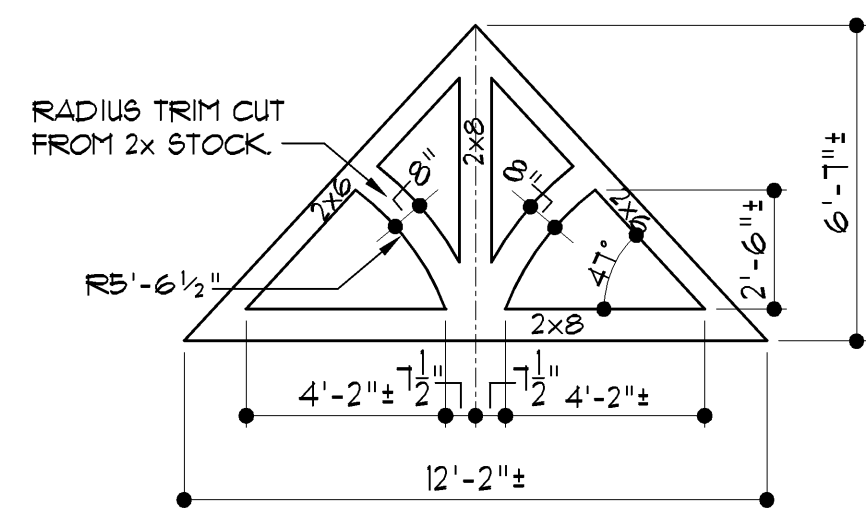

GABLE 3 TRIM DETAIL

NOTE: FIELD VERIFY GABLE DIMENSIONS PRIOR TO LAYOUT OF GABLE TRIM.

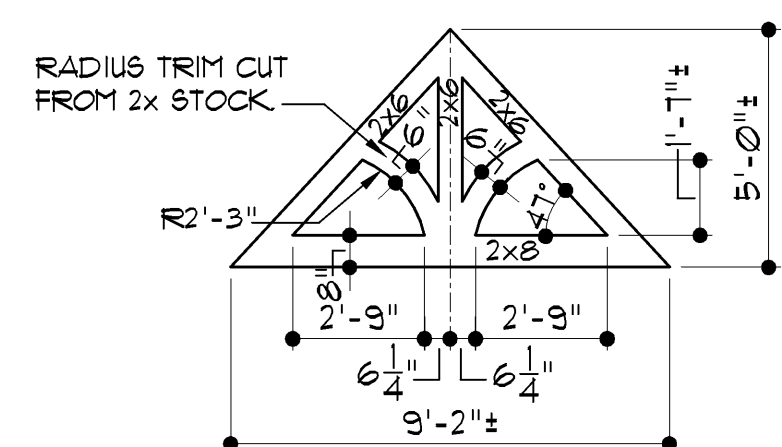

GABLE 4 TRIM DETAIL

NOTE: FIELD VERIFY GABLE DIMENSIONS PRIOR TO LAYOUT OF GABLE TRIM.

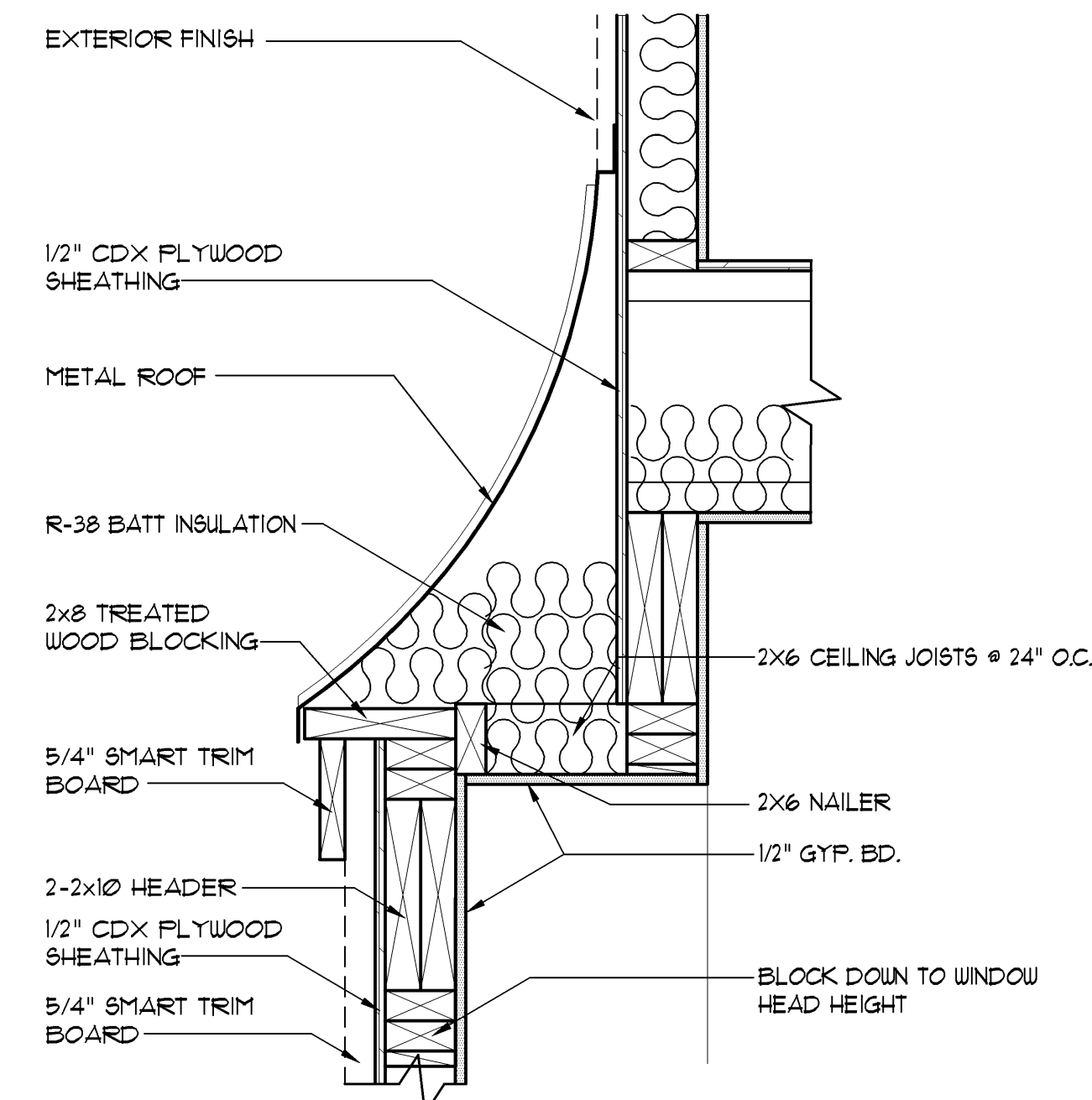

METAL 2 ROOF DETAIL



SHOULD THE CONTRACTOR FIND DISCREPANCIES OR AMBIGUITIES IN, OR OMISSIONS FROM THE DRAWINGS, NOTIFY THE ARCHITECT FOR CLARIFICATION PRIOR TO CONSTRUCTION.

VERIFY ALL ROUGH OPENING DIMENSIONS FOR SELECTED DOORS, WINDOWS, AND MECHANICAL REQUIREMENTS BEFORE CONSTRUCTION BEGINS.

ALL MANUFACTURED ITEMS, MATERIALS, AND EQUIPMENT SHALL BE INSTALLED, ERECTED, APPLIED, USED, CONDITIONED, ADJUSTED, AND CLEANED IN ACCORDANCE WITH THE CURRENT DIRECTIONS, INSTRUCTIONS, AND RECOMMENDATIONS OF THE MANUFACTURER AND WITH CURRENT PRINTED STANDARD SPECIFICATIONS WHICH ARE ISSUED AND RECOMMENDED BY ORGANIZED ASSOCIATIONS OF MANUFACTURERS, CRAFTS, AND TRADES.

ELEVATION NOTES

- E.1 ROOFING TO BE COMPOSITION SHINGLES ON 30# FELT ON 1/2" CDX PLYWOOD SHEATHING OR 1/2" OSB.
- E.2 SIDING ON REAR AND SIDES TO BE "INNERSEAL" ON 1/2" OSB. CONT. SHEATHING W/ 1/4" SMART TRIM AT ALL CORNERS. INSTALL PER MANUFACTURER'S INSTRUCTIONS. PROVIDE 1/4" SMART TRIM AROUND WINDOWS.
- E.3 STUCCO ON METAL LATH ON 30# FELT OVER 1/2" OSB. (CONTINUOUS SHEATHING) EXTEND STUCCO TO WITHIN 8' OF FINISHED GRADE.
- E.4 CAST STONE VENEER. INSTALL PER MANUFACTURER'S INSTRUCTIONS.
- E.5 NOT USED.
- E.6 TIGHT BARGE
- E.7 EXTEND FLOOR FRAMING AND INSULATE SOFFIT
- E.8 NOT USED.
- E.9 NOT USED.
- E.10 NOT USED.
- E.11 NOT USED.
- E.12 NOT USED.
- E.13 2- 5/4" x 6" SMART TRIM W/ FLASHING BEHIND.

COPYRIGHT 2018 - GENTRY DESIGN STUDIO
THESE PLANS ARE COPYRIGHTED AND PROTECTED BY GENTRY DESIGN STUDIO. ANY REPRODUCTION OR USE OF THESE PLANS WITHOUT THE WRITTEN PERMISSION OF GENTRY DESIGN STUDIO IS STRICTLY PROHIBITED. THE PROTECTION INCLUDES BUT IS NOT LIMITED TO THE GENERAL FORM AS WELL AS THE ARRANGEMENT AND COMPOSITION OF THE PLANS. ANY REPRODUCTION OR USE OF THESE PLANS WITHOUT THE WRITTEN PERMISSION OF GENTRY DESIGN STUDIO IS STRICTLY PROHIBITED. THESE PLANS ARE NOT TO BE REPRODUCED, COPIED, OR ASSIGNED TO A THIRD PARTY.

GENTRY DESIGN STUDIO
128 SOUTH CHESTNUT • OLATHE, KS 66061
PHONE - 913-393-0175

NO. DATE DESCRIPTION

ABP FUNDING, LLC
9101 W. 110TH ST., #200, • 913-208-2288
OVERLAND PARK, KANSAS 66201

DRAWN BY: LG
DATE: 11-01-2018
PROJECT NO: 02DUG10

EVANSTON 'D'
1 FRONT ELEVATION

SHEET NO. **A1**