

NOTE:
 1. ALL LOT PINS ARE TO BE SET UP ON COMPLETION OF CONSTRUCTION, ANTICIPATED COMPLETION OCTOBER, 2019. (LOT PINS NOT SHOWN FOR CLARITY)
 2. NO OIL OR GAS WELLS ARE KNOWN TO EXIST ON THIS PROPERTY PER MISSOURI GEOLOGICAL SURVEY.

FLOOD STATEMENT:
 SUBJECT PROPERTY IS SHOWN TO BE LOCATED IN "OTHER AREAS ZONE X" ON THE FLOOD INSURANCE RATE MAP FOR JACKSON COUNTY, MISSOURI AND INCORPORATED AREAS. COMMUNITY PANEL NO. 29095004166, REVISED DATE JANUARY 20, 2017. "OTHER AREAS ZONE X" IS DEFINED AS "AREAS DETERMINED TO BE OUTSIDE THE 0.2% ANNUAL CHANCE FLOODPLAIN". LOCATION DETERMINED BY A SCALED GRAPHICAL PLOT OF THE FLOOD INSURANCE RATE MAP.

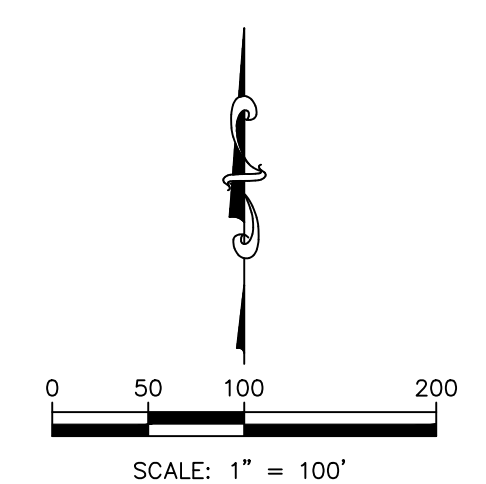

- LEGEND**
- 5/8"X24" REBAR W/AVE LS 214F CAP SET SEE NOTE 1, THIS SHEET
 - MONUMENT FOUND, ORIGIN UNKNOWN UNLESS OTHERWISE NOTED
 - △ SECTION CORNER FOUND
 - ⊠ RIGHT-OF-WAY MARKER FOUND
 - (M) MEASURED
 - (C) CALCULATED
 - CB CHORD BEARING
 - CD CHORD DISTANCE
 - U.E. UTILITY EASEMENT
 - S.E. SANITARY EASEMENT
 - S.W.E. SIDEWALK EASEMENT
 - P.C.A.E. PUBLIC COMMON AREA EASEMENT
 - LACK OF ABUTTERS RIGHTS
 - ⊠ BOUNDARY COORDINATE

**CITY OF LEE'S SUMMIT
 MAYOR AND CITY COUNCIL CERTIFICATION:**
 THIS IS TO CERTIFY THAT THE ACCOMPANYING PLAT OF STREETS OF WEST PRYOR LOTS 1 THRU 14, TRACTS "A", "B", "C", & "D" WAS SUBMITTED TO AND DULY APPROVED BY THE MAYOR AND CITY COUNCIL OF THE CITY OF LEE'S SUMMIT, MISSOURI THIS DAY OF _____ 20__ BY ORDINANCE NO. _____

WILLIAM A. BAIRD, MAYOR _____ DATE _____
 TRISHA FOWLER ARCURI, CITY CLERK _____ DATE _____

**APPROVED
 PUBLIC WORKS / ENGINEERING:**
 GEORGE W. BINGER, III, P.E., CITY ENGINEER _____ DATE _____

PLANNING AND SPECIAL PROJECTS:
 ROBERT G. MCKAY, AICP, DIRECTOR OF PLANNING AND SPECIAL PROJECTS _____ DATE _____

PLANNING COMMISSION:
 DANA ARTH, SECRETARY _____ DATE _____

**JACKSON COUNTY:
 APPROVED: ASSESSOR'S OFFICE**
 _____ DATE _____
 JACKSON COUNTY ASSESSOR

SEE SHEETS 3 & 4 FOR EASEMENT TIE DOWN DIMENSIONS

**FINAL PLAT
 STREETS OF WEST PRYOR
 LOTS 1 THRU 14,
 TRACTS "A", "B", "C", & "D"
 TO
 LEE'S SUMMIT, MISSOURI**



DATE OF PREPARATION: JANUARY 22, 2019 PROJECT NO. A14_7067-1 SHEET 1 OF 5

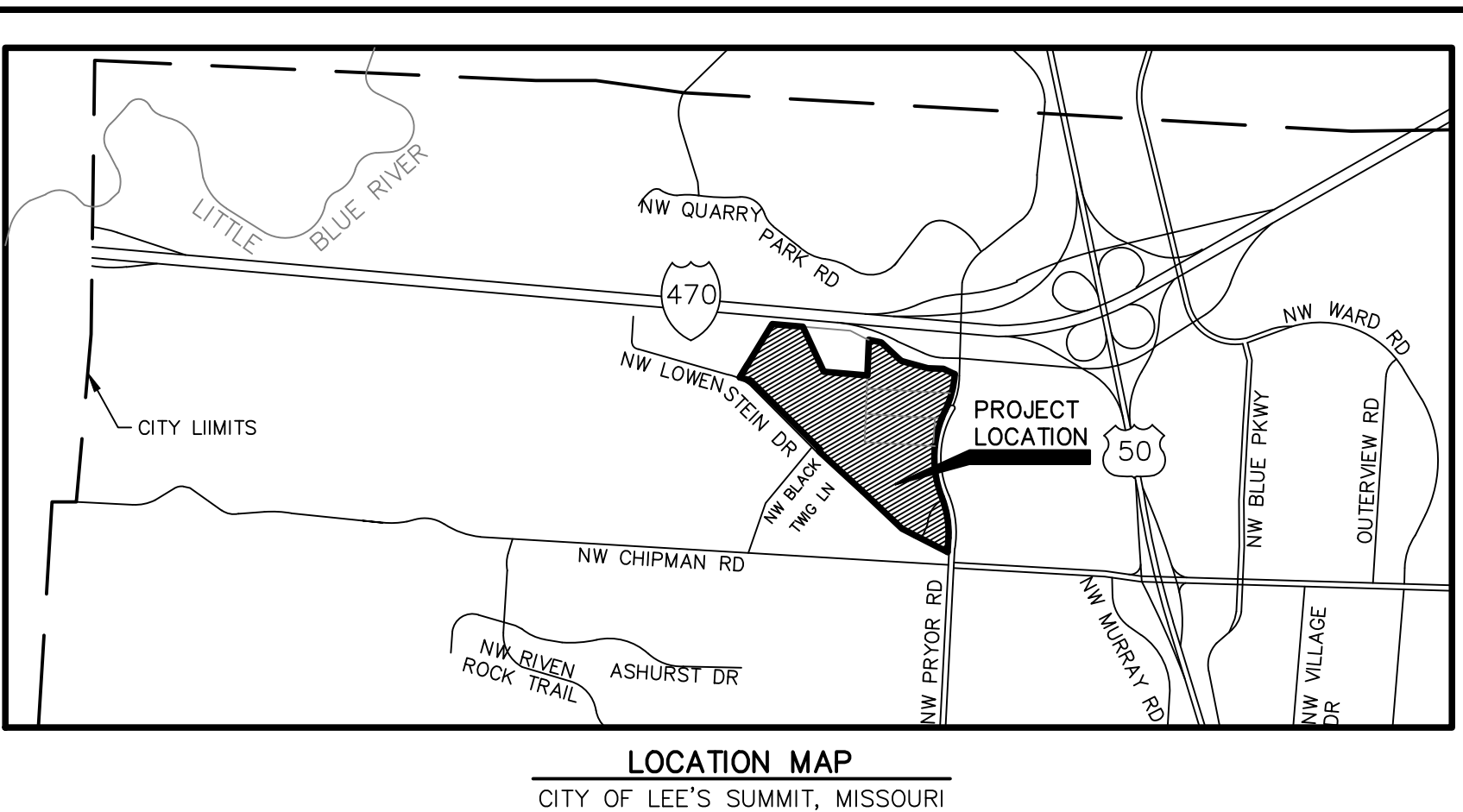
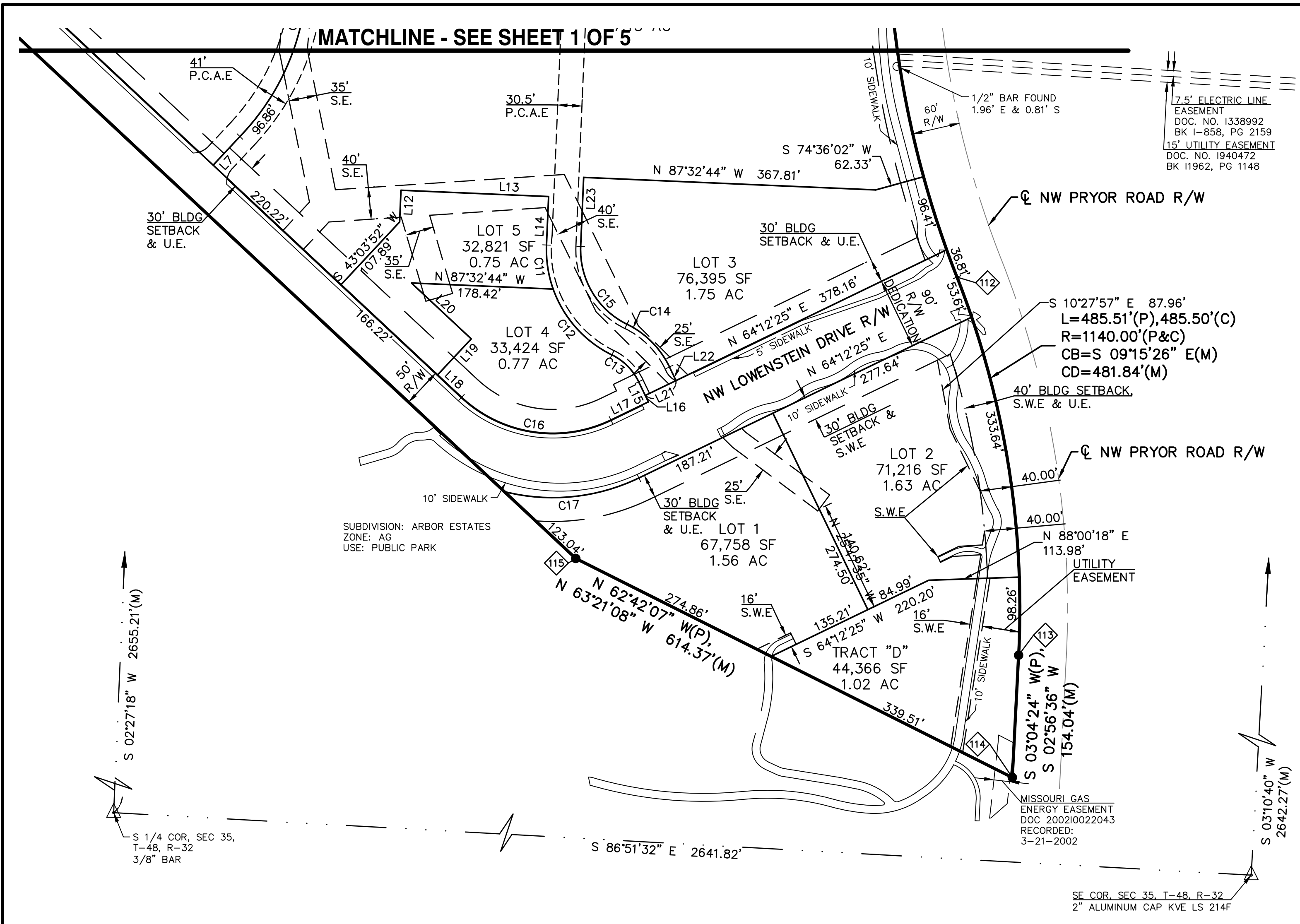

COORDINATE TABLE

POINT #	NORTHING	EASTING
100	1007391.33	2811593.79
101	1007700.59	2811782.46
102	1007670.80	2812140.78
103	1007144.64	2812384.22
104	1007101.16	2812893.73
105	1007518.07	2812911.60
106	1007486.79	2813056.82
107	1007270.33	2813288.69
108	1007185.45	2813600.27
109	1007178.16	2813782.18
110	1007116.28	2813912.93
111	1006689.02	2813800.90
112	1005678.45	2813762.03
113	1005202.89	2813839.54
114	1005049.05	2813831.63
115	1005324.60	2813282.52
116	1006216.05	2812328.71
117	1006233.96	2812346.16
118	1006254.45	2812324.24
119	1007040.27	2811533.06
120	1007078.58	2811402.99

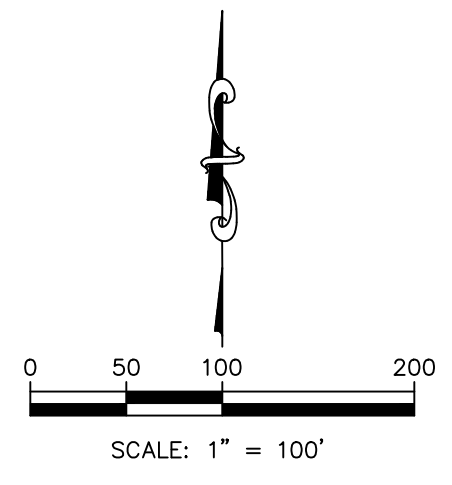

CURVE TABLE

CURVE	CHORD BEARING	CHORD LENGTH	TANGENT	RADIUS	DELTA	
C1	S 54°52'02" W	212.87'	216.87'	112.65'	381°3'58"	
C2	S 72°26'39" W	209.36'	214.78'	113.20'	44°44'56"	
C3	S 31°58'32" E	138.09'	138.45'	69.59'	147°1'35"	
C4	S 43°39'04" E	67.12'	67.19'	33.66'	90°3'29"	
C5	S 49°27'13" E	24.67'	24.67'	12.34'	555.00'	2°32'48"
C6	S 27°11'23" E	195.68'	201.29'	106.72'	245.00'	47°04'28"
C7	N 20°18'39" E	36.55'	37.64'	20.00'	45.00'	47°55'37"
C8	N 20°18'39" E	162.46'	167.29'	88.89'	200.00'	47°55'35"
C9	N 22°06'53" W	253.34'	257.78'	133.55'	400.00'	36°55'29"
C10	N 13°57'34" E	301.47'	315.86'	174.34'	300.00'	60°19'29"
C11	S 8°32'21" E	56.07'	56.41'	28.56'	147.00'	21°59'13"
C12	S 41°43'35" E	111.06'	113.88'	59.97'	147.00'	44°23'17"
C13	N 44°51'25" W	47.69'	48.58'	25.23'	73.00'	38°07'38"
C14	N 44°51'25" W	75.78'	77.19'	40.09'	116.00'	38°07'38"
C15	S 30°43'59" E	113.86'	120.48'	68.02'	104.00'	66°22'30"
C16	S 81°21'52" E	189.97'	201.90'	115.16'	168.00'	68°51'27"
C17	N 84°11'16" E	170.17'	173.67'	90.54'	249.00'	39°57'43"

LINE TABLE

LINE	BEARING	LENGTH
L1	N 58°36'52" W	16.45'
L2	S 16°00'59" E	28.89'
L3	N 4°45'09" E	17.00'
L4	S 85°14'51" E	71.09'
L5	S 50°52'40" W	130.00'
L6	N 41°49'12" E	130.00'
L7	S 43°03'52" W	49.28'
L8	N 73°47'49" E	28.02'
L9	N 73°47'49" E	42.44'
L10	S 16°12'11" E	97.91'
L11	N 87°32'44" W	21.89'
L12	S 2°27'16" W	40.00'
L13	N 87°32'44" W	185.86'
L14	N 2°27'16" E	60.96'
L15	N 25°47'35" W	19.08'
L16	N 25°47'35" W	9.00'
L17	N 64°12'25" E	52.31'
L18	N 46°56'08" W	41.35'
L19	S 43°03'52" W	62.00'
L20	S 46°56'08" E	102.98'
L21	N 64°12'25" E	43.00'
L22	N 25°47'35" W	19.08'
L23	N 2°27'16" E	86.95'
L24	N 15°22'47" E	37.29'
L25	N 71°41'12" W	61.48'

**CITY OF LEE'S SUMMIT
MAYOR AND CITY COUNCIL CERTIFICATION:**
THIS IS TO CERTIFY THAT THE ACCOMPANYING PLAT OF STREETS OF WEST PRYOR LOTS 1 THRU 14, TRACTS "A", "B", "C", & "D" WAS SUBMITTED TO AND DULY APPROVED BY THE MAYOR AND CITY COUNCIL OF THE CITY OF LEE'S SUMMIT, MISSOURI THIS DAY OF _____ 20__ BY ORDINANCE NO. _____

WILLIAM A. BAIRD, MAYOR DATE _____
TRISHA FOWLER ARCURI, CITY CLERK DATE _____

**APPROVED
PUBLIC WORKS / ENGINEERING:**
GEORGE W. BINGER, III, P.E., CITY ENGINEER DATE _____

PLANNING AND SPECIAL PROJECTS:
ROBERT G. MCKAY, AICP, DIRECTOR OF PLANNING AND SPECIAL PROJECTS DATE _____

PLANNING COMMISSION:
DANA ARTH, SECRETARY DATE _____
**JACKSON COUNTY:
APPROVED: ASSESSOR'S OFFICE**
JACKSON COUNTY ASSESSOR DATE _____

SEE SHEETS 3 & 4 FOR EASEMENT TIE DOWN DIMENSIONS

**FINAL PLAT
STREETS OF WEST PRYOR
LOTS 1 THRU 14,
TRACTS "A", "B", "C", & "D"
TO
LEE'S SUMMIT, MISSOURI**



2319 NORTH JACKSON | P.O. BOX 1304
JUNCTION CITY, KANSAS 66441
PH. (785) 762-5040 | FAX (785) 762-7744
jv@kven.com | www.kven.com

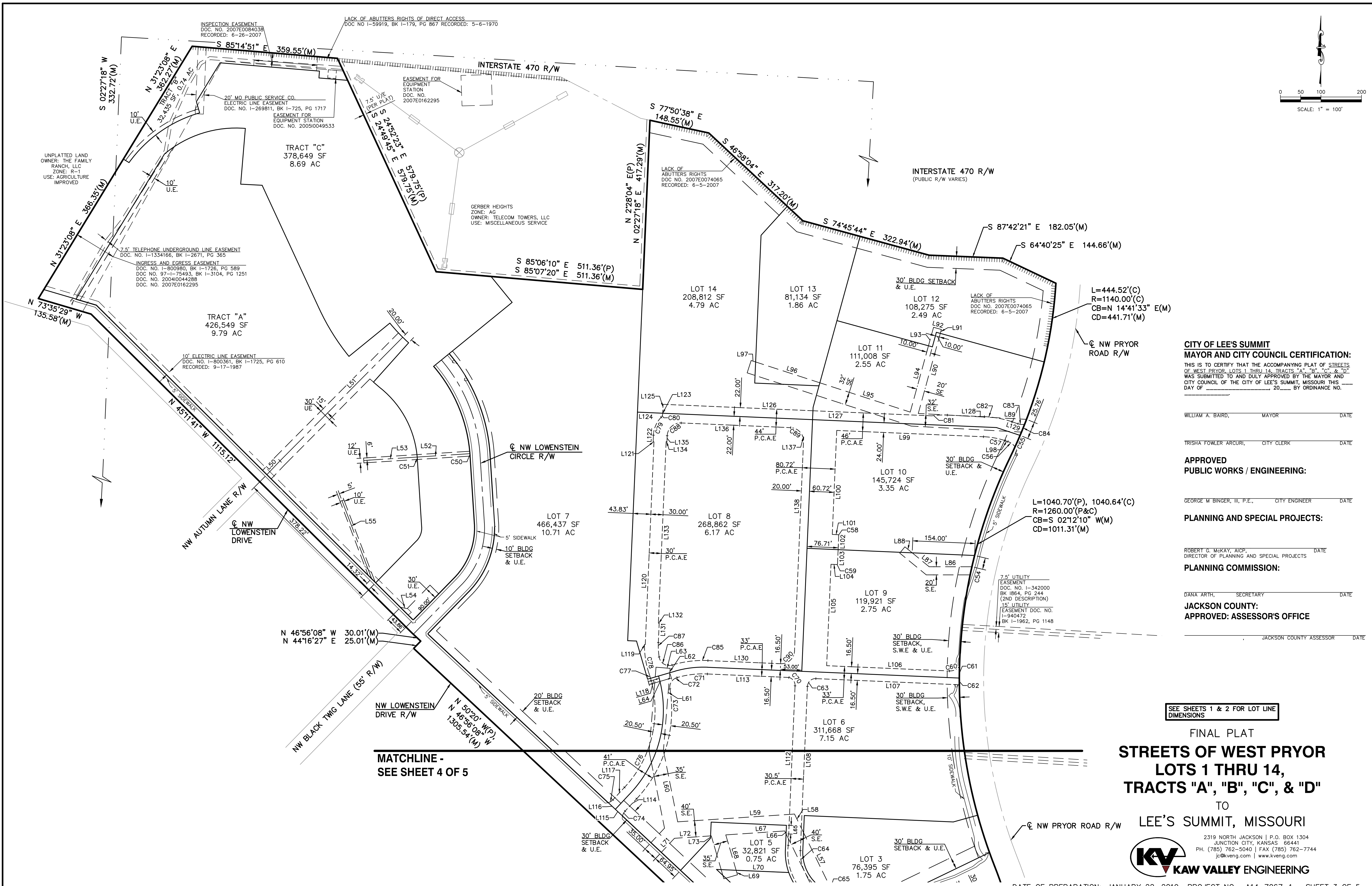
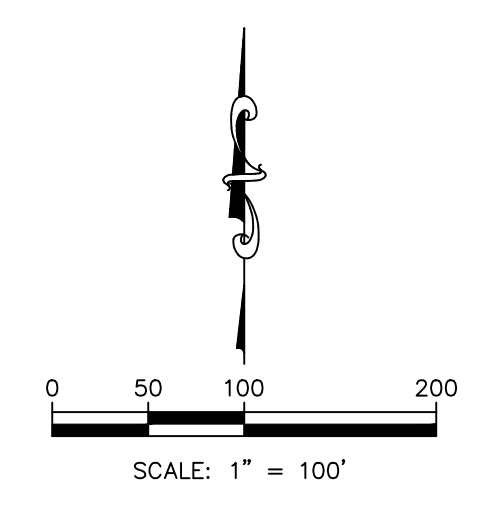

**CITY OF LEE'S SUMMIT
MAYOR AND CITY COUNCIL CERTIFICATION:**
THIS IS TO CERTIFY THAT THE ACCOMPANYING PLAT OF STREETS
OF WEST PRYOR LOTS 1 THRU 14, TRACTS "A", "B", "C", & "D"
WAS SUBMITTED TO AND DULY APPROVED BY THE MAYOR AND
CITY COUNCIL OF THE CITY OF LEE'S SUMMIT, MISSOURI THIS
DAY OF _____ 20____ BY ORDINANCE NO. _____

WILLIAM A. BAIRD, MAYOR DATE _____

TRISHA FOWLER ARCURI, CITY CLERK DATE _____

**APPROVED
PUBLIC WORKS / ENGINEERING:**

GEORGE W. BINGER, III, P.E., CITY ENGINEER DATE _____

PLANNING AND SPECIAL PROJECTS:

ROBERT G. MCKAY, AICP, DIRECTOR OF PLANNING AND SPECIAL PROJECTS DATE _____

PLANNING COMMISSION:

DANA ARTH, SECRETARY DATE _____

**JACKSON COUNTY:
APPROVED: ASSESSOR'S OFFICE**

JACKSON COUNTY ASSESSOR DATE _____

SEE SHEETS 1 & 2 FOR LOT LINE DIMENSIONS

FINAL PLAT
**STREETS OF WEST PRYOR
LOTS 1 THRU 14,
TRACTS "A", "B", "C", & "D"**
TO
LEE'S SUMMIT, MISSOURI



DATE OF PREPARATION: JANUARY 22, 2019 PROJECT NO. A14_7067-1 SHEET 3 OF 5

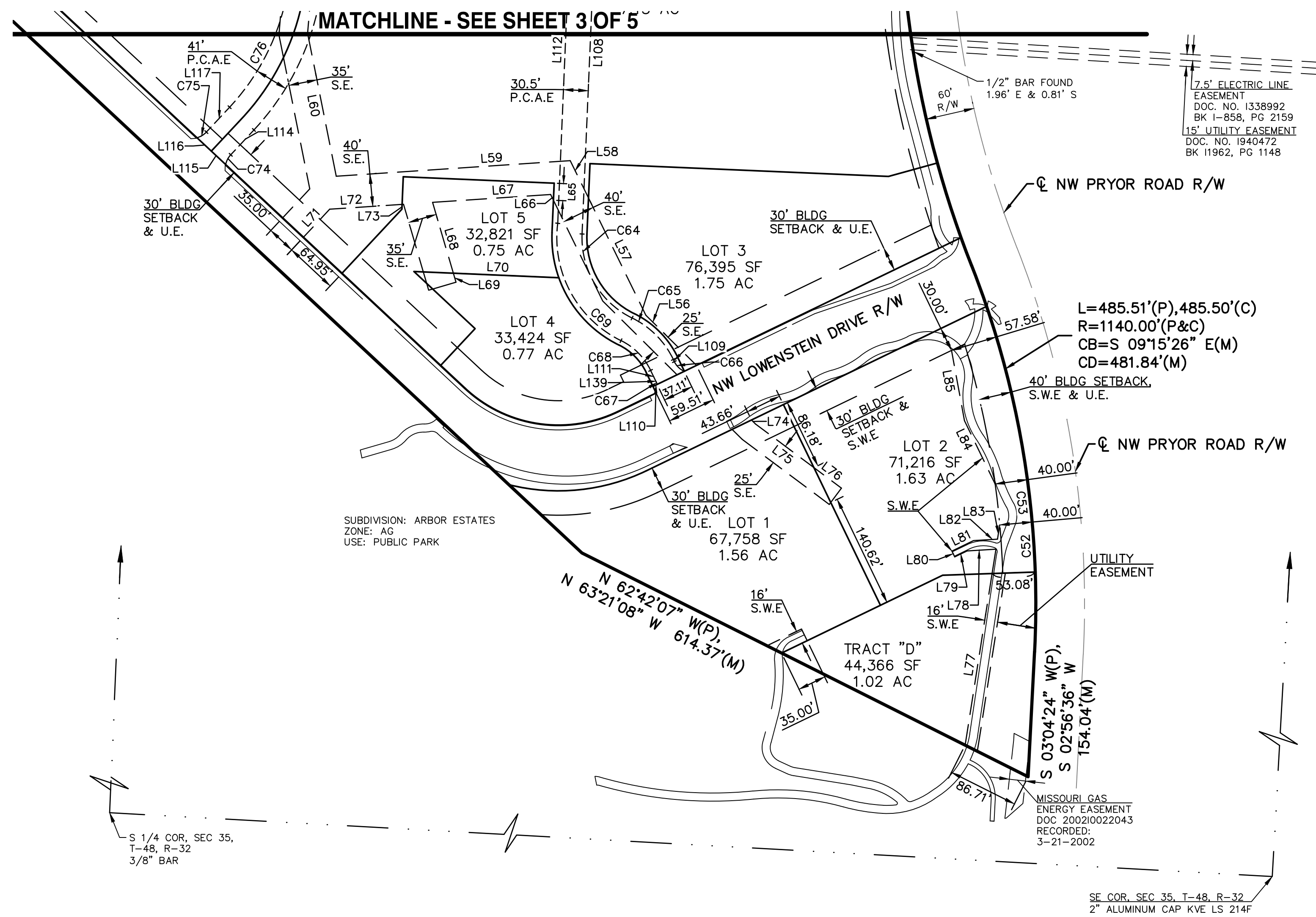

CURVE TABLE						
CURVE	CHORD BEARING	CHORD	LENGTH	TANGENT	RADIUS	DELTA
C50	N 4°03'40" W	5.35'	5.35'	2.67'	375.00'	0°49'02"
C51	N 4°16'40" W	5.35'	5.35'	2.67'	245.00'	1°15'03"
C52	N 3°32'39" W	61.64'	61.65'	30.83'	1140.00'	3°05'55"
C53	N 8°24'52" W	52.56'	52.56'	26.29'	1140.00'	2°38'30"
C54	S 13°23'36" W	28.50'	28.50'	14.25'	1260.00'	1°17'45"
C55	N 23°45'40" E	31.04'	31.04'	15.52'	1140.00'	1°33'36"
C56	N 53°23'26" W	21.97'	22.35'	11.57'	35.00'	36°35'32"
C57	N 79°36'58" W	54.63'	54.80'	27.58'	198.00'	15°51'32"
C58	N 42°32'44" W	2.83'	3.14'	2.00'	2.00'	90°00'00"
C59	N 47°27'16" E	2.83'	3.14'	2.00'	2.00'	90°00'00"
C60	N 65°16'56" E	27.40'	28.45'	15.40'	30.00'	54°20'40"
C61	S 0°49'14" W	29.02'	29.03'	14.51'	1260.00'	1°19'11"
C62	S 0°12'54" E	16.52'	16.52'	8.26'	1260.00'	0°45'04"
C63	S 47°27'16" W	28.28'	31.42'	20.00'	20.00'	90°00'00"
C64	S 30°43'59" E	120.42'	127.43'	71.95'	110.00'	66°22'30"
C65	N 44°51'25" W	71.86'	73.20'	38.01'	110.00'	38°07'38"
C66	S 45°41'21" E	17.02'	17.36'	9.05'	25.00'	39°47'31"
C67	S 21°11'23" E	4.01'	4.02'	2.01'	25.00'	9°12'25"
C68	N 44°51'25" W	51.61'	52.57'	27.30'	79.00'	38°07'38"
C69	S 28°19'11" E	164.16'	175.22'	100.95'	141.00'	71°12'06"
C70	N 36°12'19" W	25.61'	27.66'	16.40'	20.50'	77°19'11"
C71	S 83°12'10" W	75.08'	75.41'	38.03'	233.50'	18°30'11"
C72	S 32°19'25" W	33.21'	36.33'	22.22'	25.00'	83°15'19"
C73	N 16°52'49" E	282.85'	292.94'	157.60'	320.50'	52°22'07"
C74	S 27°23'54" W	13.50'	13.67'	7.01'	25.00'	31°19'56"
C75	N 58°43'50" E	13.50'	13.67'	7.01'	25.00'	31°19'56"
C76	N 13°25'51" E	276.40'	289.12'	159.00'	279.50'	59°16'03"
C77	N 17°24'36" W	11.78'	11.78'	5.89'	279.50'	2°24'52"
C78	S 8°55'47" E	73.03'	73.38'	37.04'	217.00'	19°22'31"
C79	S 23°24'56" W	47.94'	49.02'	25.67'	67.00'	41°55'19"
C80	N 23°24'56" E	9.30'	9.51'	4.98'	13.00'	41°55'19"
C81	S 87°16'21" W	38.75'	38.80'	19.45'	214.50'	10°21'53"
C82	N 79°36'58" W	68.29'	68.51'	34.47'	247.50'	15°51'32"
C83	S 85°29'05" E	16.70'	16.86'	8.60'	35.00'	27°35'46"
C84	N 22°14'19" E	29.55'	29.55'	14.78'	1140.00'	1°29'07"
C85	S 82°49'40" W	89.13'	89.55'	45.20'	266.50'	19°15'13"
C86	S 57°45'40" E	37.76'	42.79'	28.80'	25.00'	98°04'34"
C87	S 3°08'03" E	35.64'	35.70'	17.91'	183.00'	1°11'03"
C88	S 47°27'17" W	46.67'	51.84'	33.00'	33.00'	90°00'00"
C89	N 52°34'14" W	37.83'	40.29'	23.09'	33.00'	69°57'00"
C90	N 47°27'15" E	46.67'	51.84'	33.00'	33.00'	90°00'02"

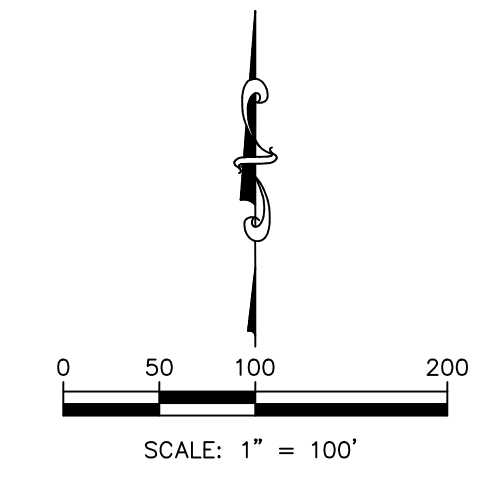

**CITY OF LEE'S SUMMIT
MAYOR AND CITY COUNCIL CERTIFICATION:**
THIS IS TO CERTIFY THAT THE ACCOMPANYING PLAT OF STREETS OF WEST PRYOR LOTS 1 THRU 14, TRACTS "A", "B", "C", & "D" WAS SUBMITTED TO AND DULY APPROVED BY THE MAYOR AND CITY COUNCIL OF THE CITY OF LEE'S SUMMIT, MISSOURI THIS DAY OF _____, 20__ BY ORDINANCE NO. _____

WILLIAM A. BAIRD, MAYOR DATE

TRISHA FOWLER ARCURI, CITY CLERK DATE

**APPROVED
PUBLIC WORKS / ENGINEERING:**

GEORGE W. BINGER, III, P.E., CITY ENGINEER DATE

PLANNING AND SPECIAL PROJECTS:

ROBERT G. MCKAY, AICP, DIRECTOR OF PLANNING AND SPECIAL PROJECTS DATE

PLANNING COMMISSION:

DANA ARTH, SECRETARY DATE

**JACKSON COUNTY:
APPROVED: ASSESSOR'S OFFICE**

JACKSON COUNTY ASSESSOR DATE

SEE SHEETS 1 & 2 FOR LOT LINE DIMENSIONS

LINE TABLE			LINE TABLE			LINE TABLE			LINE TABLE			LINE TABLE		
LINE	BEARING	LENGTH	LINE	BEARING	LENGTH	LINE	BEARING	LENGTH	LINE	BEARING	LENGTH	LINE	BEARING	LENGTH
L50	N 43°33'51" E	46.71'	L70	N 87°32'44" W	129.93'	L90	N 15°22'47" E	204.76'	L110	S 64°12'25" W	5.68'	L130	S 87°32'44" E	179.38'
L51	N 44°48'19" E	429.64'	L71	N 43°03'52" E	47.19'	L91	N 15°22'47" E	10.00'	L111	S 25°47'35" E	15.08'	L131	S 22°7'16" W	47.65'
L52	N 86°20'51" E	130.02'	L72	N 86°11'24" E	89.35'	L92	S 74°37'13" E	20.00'	L112	S 22°7'16" W	393.57'	L132	S 87°32'35" E	2.00'
L53	N 86°20'51" E	132.07'	L73	S 22°7'16" W	5.94'	L93	N 15°22'47" E	47.29'	L113	S 87°32'44" E	201.38'	L133	N 22°7'16" E	448.00'
L54	N 79°10'18" W	16.61'	L74	S 45°12'45" E	6.92'	L94	N 15°22'47" E	169.55'	L114	N 43°03'52" E	41.82'	L134	S 87°32'44" E	2.00'
L55	N 20°49'59" W	205.57'	L75	S 53°13'59" E	89.76'	L95	N 72°02'28" W	234.40'	L115	S 46°56'08" E	24.20'	L135	N 22°7'16" E	14.51'
L56	S 45°12'45" E	87.75'	L76	S 53°13'59" E	42.33'	L96	N 72°02'28" W	166.53'	L116	S 46°56'08" E	24.09'	L136	N 87°32'44" W	270.50'
L57	S 26°04'02" E	160.68'	L77	N 8°55'24" E	213.90'	L97	N 72°02'28" W	11.56'	L117	S 43°03'52" W	41.82'	L137	S 87°32'44" E	2.00'
L58	S 26°04'02" E	51.17'	L78	S 86°30'33" W	35.56'	L98	S 71°41'12" E	6.75'	L118	S 73°47'49" W	20.50'	L138	N 22°7'16" E	527.80'
L59	N 86°11'24" E	288.63'	L79	S 64°12'25" W	16.87'	L99	S 87°32'44" E	362.32'	L119	N 89°14'31" W	1.91'			
L60	N 11°19'49" W	179.48'	L80	S 25°47'35" E	8.00'	L100	N 22°7'16" E	256.65'	L120	N 22°7'16" E	500.02'			
L61	N 4°41'24" E	192.24'	L81	S 64°12'25" W	29.61'	L101	N 87°32'44" W	13.99'	L121	N 87°32'44" W	2.00'			
L62	N 4°41'24" E	10.82'	L82	S 86°30'33" W	29.51'	L102	N 22°7'16" E	34.83'	L122	N 22°7'16" E	16.51'			
L63	N 85°18'36" W	35.00'	L83	N 8°55'24" E	17.70'	L103	N 22°7'16" E	34.82'	L123	N 22°7'16" E	1.55'			
L64	S 73°47'49" W	57.00'	L84	N 25°47'35" W	86.63'	L104	S 87°32'44" E	13.99'	L124	N 87°32'44" W	62.30'			
L65	S 22°7'16" W	20.99'	L85	S 10°27'57" E	87.96'	L105	N 22°7'16" E	250.19'	L125	N 22°7'16" E	22.00'			
L66	S 26°04'02" E	7.87'	L86	N 90°00'00" W	105.43'	L106	N 87°32'44" W	303.04'	L126	N 87°32'44" W	370.02'			
L67	N 86°11'24" E	145.62'	L87	N 50°38'01" W	54.11'	L107	S 87°32'44" E	354.23'	L127	N 87°32'44" W	293.02'			
L68	N 16°19'56" W	90.88'	L88	N 50°38'01" W	23.31'	L108	N 22°7'16" E	405.44'	L128	N 87°32'44" W	91.43'			
L69	N 16°19'56" W	11.55'	L89	S 86°52'41" E	267.42'	L109	N 25°47'35" W	3.08'	L129	N 71°41'12" W	16.37'			

FINAL PLAT
**STREETS OF WEST PRYOR
LOTS 1 THRU 14,
TRACTS "A", "B", "C", & "D"**
TO
LEE'S SUMMIT, MISSOURI



DATE OF PREPARATION: JANUARY 22, 2019 PROJECT NO. A14_7067-1 SHEET 4 OF 5

KAW VALLEY ENGINEERING, INC. IS AUTHORIZED TO OFFER SURVEYING SERVICES BY MISSOURI STATE CERTIFICATE OF AUTHORIZATION NO. 000214. EXPIRES 12/31/19

SURVEYORS DESCRIPTION:

ALL OF LOT 1, PRYOR ACRES RECORDED IN BOOK 147 PAGE 36, ALL OF CORLEW'S ESTATES RECORDED IN BOOK 35, PAGE 54, ALL OF ERICKSON ACRES, 1ST PLAT, RECORDED AS DOCUMENT 20010086408, ALL OF LOT 17, TRACT C AND TRACT D, AND A PORTION OF LOT 18 CHIPMAN-HWY 50, RECORDED IN BOOK 168, PAGE 62, A PORTION OF LOWENSTEIN DRIVE RIGHT-OF-WAY, AND UN-PLATTED LAND IN THE SOUTH HALF OF SECTION 35, TOWNSHIP 48, RANGE 32, CITY OF LEE'S SUMMIT, COUNTY OF JACKSON, STATE OF MISSOURI, BEING DESCRIBED AS FOLLOWS:

COMMENCING AT THE NORTHWEST CORNER OF THE SOUTHEAST QUARTER OF SAID SECTION 35; THENCE ON THE WEST LINE OF SAID SOUTHEAST QUARTER, ON AN ASSUMED BEARING OF S 02°27'18" W 332.72 FEET TO THE POINT OF BEGINNING; THENCE N 31°23'08" E 362.27 FEET TO THE SOUTH RIGHT-OF-WAY LINE OF INTERSTATE 470; THENCE ON SAID SOUTH RIGHT-OF-WAY LINE, S 85°14'51" E 359.55 FEET TO THE NORTHWEST CORNER OF GERBER HEIGHTS RECORDED IN BOOK 151, PAGE 74; THENCE ON THE WESTERLY LINE OF SAID GERBER HEIGHTS, S 24°49'45" E 579.75 FEET TO THE SOUTHWEST CORNER OF SAID GERBER HEIGHTS; THENCE ON THE SOUTH LINE OF SAID GERBER HEIGHTS, S 85°07'20" E 511.36 FEET TO THE SOUTHEAST CORNER OF SAID GERBER HEIGHTS; THENCE ON SAID EAST LINE, N 02°27'18" E 417.29 FEET TO THE SOUTHERLY RIGHT-OF-WAY LINE OF INTERSTATE HIGHWAY 470; THENCE ON SAID SOUTHERLY RIGHT-OF-WAY LINE, S 77°50'38" E 148.55 FEET; THENCE ON SAID SOUTHERLY RIGHT-OF-WAY LINE, S 46°58'04" E 317.20 FEET; THENCE ON SAID SOUTHERLY RIGHT-OF-WAY LINE, S 74°45'44" E 322.94 FEET; THENCE ON SAID SOUTHERLY RIGHT-OF-WAY LINE, S 87°42'21" E 182.05 FEET; THENCE ON SAID SOUTHERLY RIGHT-OF-WAY LINE, S 64°40'25" E 144.66 FEET TO THE INTERSECTION OF SAID SOUTHERLY RIGHT-OF-WAY LINE WITH THE WESTERLY RIGHT-OF-WAY LINE OF PRYOR ROAD BEING THE BEGINNING OF A NON-TANGENT CURVE TO THE RIGHT; THENCE ON SAID WESTERLY RIGHT-OF-WAY LINE, SOUTHWESTERLY ON THE ARC OF SAID CURVE HAVING A RADIUS OF 1140.00 FEET, AN ARC LENGTH OF 444.52 FEET, AND WHOSE CHORD BEARS S 14°41'33" W 441.71 FEET TO THE BEGINNING OF A REVERSE CURVE TO THE LEFT; THENCE CONTINUING ON SAID WESTERLY RIGHT-OF-WAY LINE, SOUTHERLY AND SOUTHEASTERLY ON THE ARC OF SAID CURVE HAVING A RADIUS OF 1260.00 FEET, AN ARC LENGTH OF 1040.64 FEET, AND WHOSE CHORD BEARS S 02°12'10" W 1011.31 FEET TO THE BEGINNING OF A REVERSE CURVE TO THE RIGHT; THENCE ON SAID WESTERLY RIGHT-OF-WAY LINE, SOUTHERLY ON THE ARC OF SAID CURVE HAVING A RADIUS OF 1140.00 FEET, AN ARC LENGTH OF 485.50 FEET, AND WHOSE CHORD BEARS S 09°15'26" E 481.84 FEET; THENCE CONTINUING ON SAID WESTERLY RIGHT-OF-WAY LINE, S 02°56'36" W 154.04 FEET TO THE INTERSECTION OF SAID WESTERLY RIGHT-OF-WAY LINE WITH THE SOUTHERLY RIGHT-OF-WAY LINE OF LOWENSTEIN DRIVE; THENCE ON SAID SOUTHERLY RIGHT-OF-WAY LINE, N 63°21'08" W 614.37 FEET; THENCE CONTINUING ON SAID SOUTHERLY RIGHT-OF-WAY LINE, N 46°56'08" W 1305.54 FEET TO THE SOUTHERLY RIGHT-OF-WAY LINE OF BLACK TWIG LANE; THENCE N 44°16'27" E 95.01 FEET TO THE CENTERLINE OF LOWENSTEIN DRIVE; THENCE ON SAID CENTERLINE, N 46°56'08" W 30.01 FEET; THENCE CONTINUING ON SAID CENTERLINE, N 45°11'41" W 1115.12 FEET; THENCE CONTINUING ON SAID CENTERLINE, N 73°35'29" W 135.58 FEET; THENCE N 31°23'08" E 366.35 FEET TO THE POINT OF BEGINNING.

CONTAINS 3,167,055 SQUARE FEET, 72.71 ACRES MORE OR LESS.

END OF DESCRIPTION

BASIS OF BEARINGS:

ASSUMED N 86°35'09" W ON THE NORTH LINE OF THE SOUTHEAST QUARTER OF SECTION 35, TOWNSHIP 48, RANGE 32, CITY OF LEE'S SUMMIT, COUNTY OF JACKSON, STATE OF MISSOURI.

DEDICATION

STATE OF KANSAS } SS
COUNTY OF _____

THE UNDERSIGNED OWNER(S) OF THE PROPERTY DESCRIBED HEREIN HAS/HAVE CAUSED THE SAME TO BE SUBDIVIDED IN THE MANNER SHOWN ON THIS PLAT AND THE PROPERTY SHALL HEREAFTER BE KNOWN AS
STREETS OF WEST PRYOR, LOTS 1 THRU 14, TRACTS "A", "B", "C", & "D".

EASEMENTS:

AN EASEMENT OR LICENSE IS HEREBY GRANTED TO THE CITY OF LEE'S SUMMIT, MISSOURI, TO LOCATE, CONSTRUCT AND MAINTAIN, OR TO AUTHORIZE THE LOCATION, CONSTRUCTION AND MAINTENANCE OF POLES, WIRES, ANCHORS, CONDUITS, AND/OR OTHER STRUCTURES FOR WATER, GAS, SANITARY SEWER, STORM SEWER, SURFACE DRAINAGE CHANNEL, ELECTRICITY, TELEPHONE CABLE TELEVISION, OR ANY OTHER NECESSARY PUBLIC UTILITY OR SERVICES, ANY OR ALL OF THEM, UPON, OVER, OR UNDER THOSE AREAS OUTLINE OR DESIGNATED UPON THIS PLAT AS "UTILITY EASEMENT" (UE) OR WITHIN ANY STREET OR THOROUGHFARE DEDICATED TO PUBLIC USE ON THIS PLAT. GRANTOR, ON BEHALF OF HIMSELF, HIS HEIRS, HIS ASSIGNS AND SUCCESSORS IN INTEREST, HEREBY WAIVES, TO THE FULLEST EXTENT ALLOWED BY LAW, INCLUDING, WITHOUT LIMITATION, SECTION 527.188 RSMo. (2006), ANY RIGHT TO REQUEST RESTORATION OF RIGHTS PREVIOUSLY TRANSFERRED AND VACATION OF THE EASEMENT HEREIN GRANTED.

STREETS:

ROADS AND STREETS SHOWN ON THIS PLAT AND NOT HERETOFORE DEDICATED TO PUBLIC USE AS THOROUGHFARES ARE HEREBY SO DEDICATED.

BUILDING LINES:

BUILDING LINES OR SETBACK LINES ARE HEREBY ESTABLISHED AS SHOWN ON THE ACCOMPANYING PLAT AND NO BUILDING OR PORTION THEREOF SHALL BE CONSTRUCTED BETWEEN THIS LINE AND THE STREET RIGHT OF WAY LINES.

SIDEWALKS: THE UNDERSIGNED HEREBY DEDICATES A PERMANENT SIDEWALK EASEMENT (S.W.E) OVER AND ACROSS THE LAND HEREAFTER SPECIFICALLY DESCRIBED, FOR THE PURPOSE OF CONSTRUCTING, USING, REPLACING, AND MAINTAINING PUBLIC SIDEWALK AND APPURTENANT WORK IN ANY PART OF THE EASEMENT, INCLUDING THE RIGHT TO REPAIR, MAINTAIN, AND REPLACE THE SIDEWALK, AND FOR ANY RECONSTRUCTION AND FUTURE EXPANSION OF ANY FACILITY WITHIN THE AREA OF THE EASEMENT.

COMMON AREAS: TRACTS "A", "B", "C" & "D" (20.24 ACRES)
TRACTS "A", "B", "C" & "D" ARE HEREBY RESERVED AS COMMON AREA AND SHALL BE MAINTAINED AND OWNED BY DEVELOPER OR AS OTHERWISE DEFINED IN THE SEPARATE DOCUMENT TITLED "DECLARATION OF COVENANTS, RESTRICTIONS AND EASEMENTS". THE DEVELOPER SHALL REMAIN JOINTLY AND SEVERALLY LIABLE FOR THE MAINTENANCE OBLIGATIONS DEFINED IN THE SEPARATE DOCUMENT TITLED "DECLARATION OF COVENANTS, RESTRICTIONS AND EASEMENTS".

PUBLIC COMMON AREA EASEMENT: PUBLIC COMMON AREA EASEMENTS (P.C.A.E.) AS SHOWN SHALL BE MAINTAINED IN ACCORDANCE WITH SEPARATE DOCUMENT TITLED "DECLARATION OF COVENANTS, RESTRICTIONS AND EASEMENTS". STREETS OF WEST PRYOR, LLC, THE DEVELOPER, SHALL MAINTAIN THE PUBLIC COMMON AREA EASEMENTS IN ACCORDANCE WITH SAID SEPARATE DOCUMENT.

MASTER DRAINAGE PLAN:

INDIVIDUAL LOT OWNERS(S) SHALL NOT CHANGE OR OBSTRUCT THE DRAINAGE FLOW LINES ON THE LOTS AS SHOWN BY THE MASTER DRAINAGE PLAN, UNLESS SPECIFIC APPLICATION IS MADE AND APPROVE BY THE CITY ENGINEER.

COVENANTS:

THE USE OF ALL TRACTS, LOTS, UNITS AND PROPERTIES IN THIS SUBDIVISION SHALL HEREAFTER BE SUBJECT TO COVENANTS AND RESTRICTIONS, WHICH INSTRUMENTS ARE RECORDED IN THE OFFICE OF THE RECORDER OF DEEDS OF JACKSON COUNTY, MISSOURI AND SHALL HEREBY BECOME A PART OF THE DEDICATION OF THIS PLAT AS THOUGH SET FORTH HEREIN.

IN TESTIMONY WHEREOF, THE UNDERSIGNED OWNERS HAVE HEREUNTO SET THEIR HANDS THIS _____ DAY OF _____, _____

CITY OF LEE'S SUMMIT
MATT PENNINGTON, MANAGER,
STREETS OF WEST PRYOR, LLC

NOTARY CERTIFICATE

STATE OF _____ } SS
COUNTY OF _____

BE IT REMEMBERED THAT ON THIS ____ DAY OF _____, 20____, BEFORE ME, A NOTARY PUBLIC IN AND FOR SAID COUNTY AND STATE, CAME _____ TO ME PERSONALLY KNOWN TO BE THE SAME PERSON WHO EXECUTED THE FOREGOING INSTRUMENT OF WRITING AND DULY ACKNOWLEDGED THE EXECUTION OF SAME. IN TESTIMONY WHEREOF I HAVE HEREUNTO SET MY HAND AND AFFIXED MY NOTARIAL SEAL THE DAY AND YEAR ABOVE WRITTEN.

NOTARY PUBLIC
MY COMMISSION EXPIRES _____

NOTARY CERTIFICATE

STATE OF _____ } SS
COUNTY OF _____

BE IT REMEMBERED THAT ON THIS ____ DAY OF _____, 20____, BEFORE ME, A NOTARY PUBLIC IN AND FOR SAID COUNTY AND STATE, CAME _____ TO ME PERSONALLY KNOWN TO BE THE SAME PERSON WHO EXECUTED THE FOREGOING INSTRUMENT OF WRITING AND DULY ACKNOWLEDGED THE EXECUTION OF SAME. IN TESTIMONY WHEREOF I HAVE HEREUNTO SET MY HAND AND AFFIXED MY NOTARIAL SEAL THE DAY AND YEAR ABOVE WRITTEN.

NOTARY PUBLIC
MY COMMISSION EXPIRES _____

OWNER:
STREETS OF WEST PRYOR, LLC
7200 WEST 132ND STREET
OVERLAND PARK, KS 66213
CONTACT: MATT PENNINGTON
email: matt@drakekc.com

PREPARED BY:
KAW VALLEY ENGINEERING, INC.
2319 N. JACKSON
JUNCTION CITY, KS 66441
785-762-5040
CONTACT: LEON D OSBOURN, MO PLS
EMAIL: ldo@kveng.com

DEVELOPER:
DRAKE DEVELOPMENT, LLC
7200 WEST 132ND STREET
OVERLAND PARK, KS 66213
AGENT: DAVID N. OLSON
email: daveolson@monarchprojectllc.com

SURVEYOR'S CERTIFICATE

I, THE UNDERSIGNED, DO HEREBY CERTIFY THAT I AM A REGISTERED LAND SURVEYOR IN THE STATE OF MISSOURI, WITH EXPERIENCE AND PROFICIENCY IN LAND SURVEYING, THAT THE HERETOFORE DESCRIBED PROPERTY WAS SURVEYED AND SUBDIVIDED BY ME OR UNDER MY DIRECT SUPERVISION; THAT ALL SUBDIVISION REGULATIONS OF THE CITY OF LEE'S SUMMIT, MISSOURI, HAVE BEEN COMPLIED WITH IN THE PREPARATION OF THIS PLAT; THAT THIS PLAT AND THE SURVEY ON WHICH IT IS BASED WERE MADE IN ACCORDANCE WITH THE KANSAS MINIMUM STANDARDS FOR BOUNDARY SURVEYS, AND THAT ALL THE MONUMENTS SHOWN HEREIN ACTUALLY EXIST AND THEIR POSITIONS ARE CORRECTLY SHOWN TO THE BEST OF MY KNOWLEDGE AND BELIEF.
GIVEN UNDER MY HAND AND SEAL AT JUNCTION CITY, KANSAS, THIS ____ DAY OF _____, 20____.
DATE OF SURVEY: _____

LAND SURVEYOR, JASON R. LOADER
REGISTRATION NO. 1462

**CITY OF LEE'S SUMMIT
MAYOR AND CITY COUNCIL CERTIFICATION:**

THIS IS TO CERTIFY THAT THE ACCOMPANYING PLAT OF STREETS OF WEST PRYOR, LOTS 1 THRU 14, TRACTS "A", "B", "C", & "D" WAS SUBMITTED TO AND DULY APPROVED BY THE MAYOR AND CITY COUNCIL OF THE CITY OF LEE'S SUMMIT, MISSOURI THIS ____ DAY OF _____, 20____ BY ORDINANCE NO. _____

WILLIAM A. BAIRD, MAYOR DATE

TRISHA FOWLER ARCURI, CITY CLERK DATE

**APPROVED
PUBLIC WORKS / ENGINEERING:**

GEORGE W BINGER, III, P.E., CITY ENGINEER DATE

PLANNING AND SPECIAL PROJECTS:

ROBERT G. MCKAY, AICP, DIRECTOR OF PLANNING AND SPECIAL PROJECTS DATE

PLANNING COMMISSION:

DANA ARTH, SECRETARY DATE

**JACKSON COUNTY:
APPROVED: ASSESSOR'S OFFICE**

JACKSON COUNTY ASSESSOR DATE

FINAL PLAT
**STREETS OF WEST PRYOR
LOTS 1 THRU 14,
TRACTS "A", "B", "C", & "D"**
TO
LEE'S SUMMIT, MISSOURI

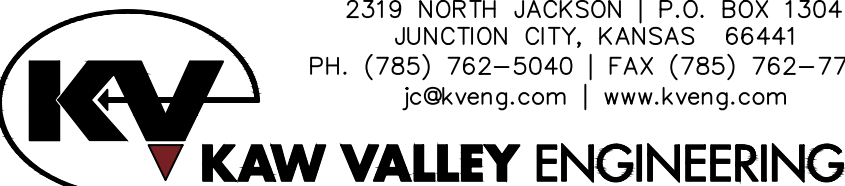

2319 NORTH JACKSON | P.O. BOX 1304
JUNCTION CITY, KANSAS 66441
PH. (785) 762-5040 | FAX (785) 762-7744
jv@kveng.com | www.kveng.com

DATE OF PREPARATION: JANUARY 22, 2019 PROJECT NO. A14_7067-1 SHEET 5 OF 5