

## **Cuddle Up Pup – Dog Daycare, Boarding, Grooming, and Retail**

In recent years it is becoming more popular for boarding facilities to veer away from the traditional kennel style and to more luxurious setting. In keeping with this trend we will emphasize on creating a home away from home atmosphere. We will do this by constructing upscale suites that will mimic a bedroom feel with cozy bedding and temper glass doors. This is uniquely different than the common kennel with the cold prison like feel. Unlike many boarding facilities that drastically limit play time during daycare we will be able to extend play times due to having multiple large indoor and outdoor play areas to section off in groups, rather than rotating groups back and forth to their runs.

Each daycare room will have sofas and toddler beds for dogs to have a comfortable place to cuddle with a friend while taking a break from play. Other attributes to the daycare room will be indoor theater, where dog specific shows will be playing. Staff will interact with the dogs by engaging different fun activities such as blowing bubbles, playing ball, or summer water activities.

We seek to create a fulfilling work environment for each member of our team. To do this we plan to give the staffing the tools they need by training them in animal behavior, health, nutrition, safety and customer service. Unlike many of our competitors we will have 24/7 staffing on site. This is appealing for many clients that are concerned with their pet being alone in a building. This offers the benefit of late night let outs to keep the dogs on the same schedule as if they were at home.

Cuddle Up Pup will be open Monday through Friday from 7am to 7pm and Saturday and Sunday from 8am to 5pm.

Staffing will be there 24/7

Dogs will be rotated outside starting at 7am. They will be taken outside at least 5 times a day. Our last let out before they go to bed will be at 9pm.

Our outside yard will have a vinyl privacy fence along the back side of the yard as well as breaking up the existing yard into multiple yards. This will reflect the noise back to our building. We will be putting in K9 Grass (included in this packet is more information on K9 grass) for our yard. This will help us keep the yard clean and sanitized. K9 Grass is a special turf that allows the solid to stay on top and the liquid to filter through into a natural filtration system. The solid will be picked up and disposed of in an air tight container that will also be disposed of into the dumpster that will be picked up one to two times a week by the trash service. After each outside group play the yard will be sprayed with a bacterial and odor eliminator cleaning agent in order to keep a sanitized area at all times.

## Frequently Asked Questions & Concerns

*Q:* What kind of training will your staff have?

*A:* Our staff will be trained in animal behavior, dog CPR, animal health, nutrition, and play group control.

*Q:* How many dogs will you allow in your facility at once?

*A:* The number of dogs fluctuates during peak times of the year. We estimate an average of 70 dogs during regular times. The dogs are divided up into groups base on size and temperament. Every group will be supervised by our staff members at all times. The dogs are never allowed to be unattended.

*Q:* How often are dogs let outside?

*A:* Dogs are let out in groups. Each group will have their own designated time to go outside every other hour for about 15 to 20 mins at a time.

*Q:* How early do the dogs go outside?

*A:* We start taking dogs out at 7am.

*Q:* What is the last time they go outside before bed?

*A:* Their last break outside is 9pm

*Q:* What kind of dogs will you allow in your facilities?

*A:* Every dog that comes into our facility must have Rabies, Distemper (DHLPP,DA2PP), Bordatella (kennel cough) and a negative fecal check annually. Dogs will be screened prior to staying with us to make sure this is the proper place for them.

*Q:* How do you handle excessive barking when the dogs are outdoors?

*A:* Our staff will be trained in how to redirect dogs in order to distract them from barking. Dogs that are playing or distracted in some activity will not excessively bark. If the staff is unable to correct this, the dog will be moved indoors.

*Q:* How do you combat the potential odors caused by animals?

*A:* We will have set cleaning procedures. Every morning the whole facility will be deep cleaned and throughout the day we will spot clean. As for the outside area, we will be putting in K9Grass which will allow the solid waste to stay on top and liquid to filter through a natural filtration system. The solid will be picked up immediately and put in a receptacle bin with an air tight lid and then be disposed of in the trash dumpster that will be picked up once to twice a week. The yards will be sprayed down after each outside breaks with a bacteria and odor eliminator cleaning agent.

## **Surrounding Neighbors and what they think.**

I have met with these surrounding business owners on Monday Aug 29<sup>th</sup>. This is who I talked to and what we discussed.

### **Summit Inn and suites – David Baddock**

David had some concerns about early morning let out and the noise that may disturb his guests. At the time of our conversation, there were three men mowing the lawn at the purpose location I was looking at. We went into the hotel to the closest room to the location to see what we could hear. We heard a faint noise coming from the lawn mowers. He felt that it would be okay. I told them that if they had any complaints that they could reach me at any time and I would rectify the situation. Plus, we discussed working together due to that fact that they are a pet friendly facility. We offered to give a discount to their customers as well as be of service to them if they have a pet that is a nuisance at their location that they could bring the animal to us at any time. I believe we will have a good working relationship.

### **ENT of greater Kansas City – Ron Boothe**

Ron Boothe had no issues with us being next to his facility. He actually thought it was great. We also talked to the receptionists at his facility and they were all for it.

### **Summit Bar and grill – Andy Lock**

Left message about what I wanted to do. Have not heard from him.  
?????????

## **What we are asking for?**

We are requesting for the use of an outside yard. Whether it be through a special use permit or a variance.

Facility model pictures

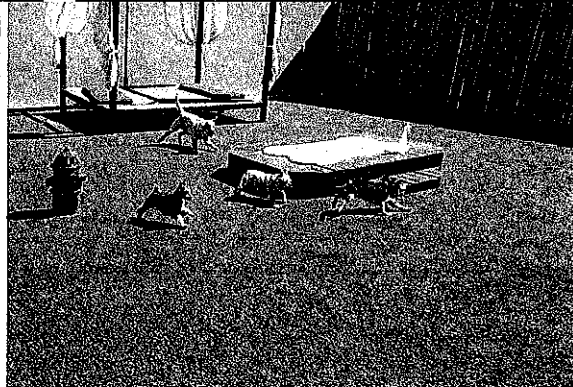
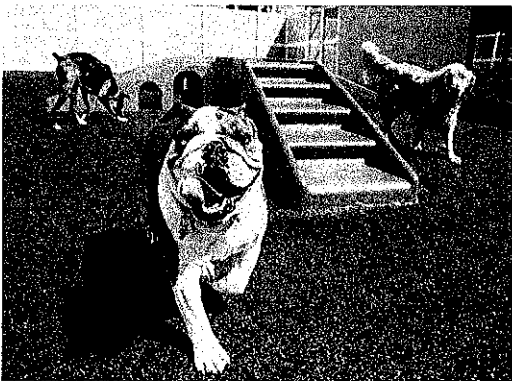
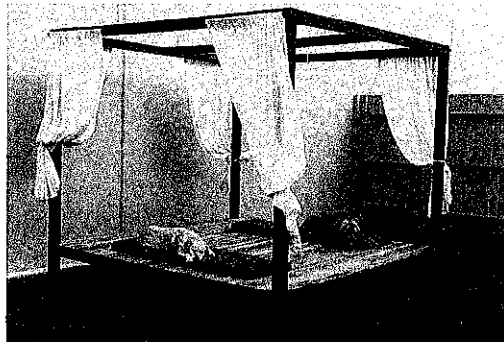
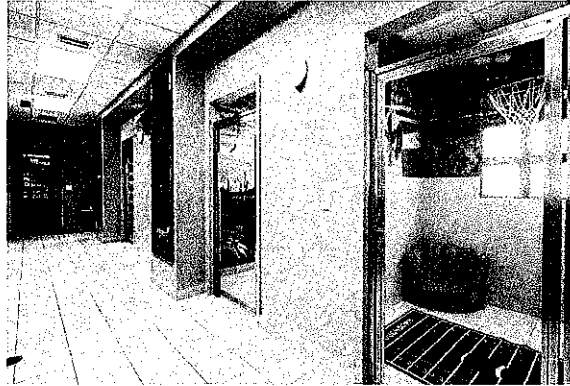
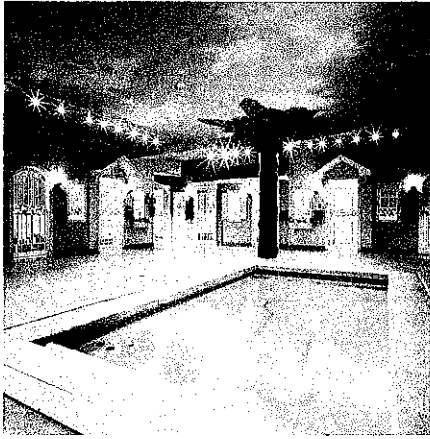

# Stephanie Mayer - Haddadi

Manager

Stephhaddadi@outlook.com

816.304.1656

16007 Terry Ave

Belton, MO 64012

## Summary

Dedicated, Experienced and Knowledgeable of the Pet Industry. Superior customer care service, patient, gentle and understanding of the different temperaments of various animals and the skills to assess potential health or behavioral problems and act accordingly for the well-being of the animal. Ability to teach and instruct others. Excellent capability of accounting and record keeping. Great critical thinking to identify the strengths and weaknesses of alternative solutions.

## Work Experience

### Manager

#### Tails R Waggin, Overland Park, KS

Apr 2010 – Current

- Managed on average of 20 employees
- Oversee daily operations
- Developed and participated in animal care training program for staffing
- Ensure the safety of animals and staffing
- Head groomer
- Receptionist
- Customer Care
- Employee Hiring/Firing
- Evaluated dog groups
- Scheduling

### Owner/Manager

#### Pet Village, LLC, Kansas City, MO

May 2008 – Apr 2010

- Managing on average 25 employees
- Reconstructed an existing Dog boarding facility into an increasingly profitable business
- Created an LLC
- Added on Dog daycare, full service grooming, and retail
- Joining with onsite Veterinarian services
- Developing daily task systems and staffing training programs
- Organizing and maintaining relevant records and filing
- Maintaining a clean, secure and fun environment
- Marketing
- Accounting

### Manager

#### Puppy's Playpen, Overland Park, KS

Mar 2004 – May 2008

- Managed on average 20 employees in a Cage-less Facility
- Head Groomer
- Trained groomers, shift leaders, pack leaders, and receptionists
- Employee Hiring/Firing
- Oversaw daily tasks

- Evaluated dog groups
- Accounting
- Scheduling
- Marketing
- Events Coordinator
- Maintained clean, safe and fun environment

### **Manager/Veterinarian Assistant**

#### **Winding River Animal Clinic, Kansas City, MO**

Jun 2001 – Mar 2004

- Managed on average 20 employees
- Assisted veterinarian in animal surgeries, appointments and other medical duties
- Assisted in Emergency after hour appointments
- Head Kennel Tech
- Employee Hiring/Firing
- Employee Training
- Receptionist
- Scheduling
- Accounting
- Rescue Group Liaison
- Maintained clean, secure and fun environment

### **Veterinarian Assistant/Head Kennel Tech**

#### **College Boulevard Animal Hospital, Overland Park, KS**

Jun 2003 – Mar 2004

- Assisted Veterinarian in animal surgeries, appointments, and other medical Duties
- Organized medical records
- Head Kennel Tech
- Receptionist/Customer Service
- Employee Training
- Scheduling
- Cleaned disinfected and maintained facility
- Fed, watered and exercised animals

### **Manager**

#### **Country Lane Kennels, Kansas City, MO**

Mar 1999 – Jun 2003

- Managed on average 15 employees
- Head Kennel Tech
- Employee Hiring/Firing
- Employee Training
- Scheduling
- Accounting
- Receptionist
- Rescue Group Liaison
- Maintained clean, secure and fun environment

### **Education**

Raymore-Peculiar High School

2003

Longveiw Community College

### **Certification and Training**

- Education in full service animal Grooming 2004
- The Humane Society of the United States - Disaster Animal Response team training Certificate 2006
- Dog CPR and Health Course - 2003 and 2011
- Animal Behavior Courses 2001, 2004, 2006 (Certificates)
- Dog Nutrition Course - Brookside Barkery 2007
- Dog and Cat Dietary needs Course - Bark to Basic 2005

## **References**

Andrea Gakeski-Mlnarik - Owner of Puppy's Playpen 816.804.2004

Dan Hecker DVM - Owner of Winding River Animal Clinic 816.590.1953

Mike Tarrant DVM - Owner of Arbor Creek Animal Clinic 913.764.9000

Brad Spain DVM - Owner of Blue Valley Animal Hospital 913.681.2818



K9 GRASS<sup>®</sup>

by ForeverLawn<sup>®</sup>

Product

Photo Gallery

Installation Process

Featured Projects

Safety

K9Grass Mats

K9Grass Profile

Contact Us

News

## K9GRASS PROFILE

K9Grass is a ForeverLawn brand. ForeverLawn is a leading supplier of synthetic turf that was created out of a desire to develop and provide the highest quality, most technologically advanced synthetic grass products for a variety of uses. For more information on ForeverLawn, visit [www.foreverlawn.com](http://www.foreverlawn.com).

For several years, we had installed our synthetic grasses for use with dogs in yards and kennels. While synthetic turf definitely offered advantages, there were very distinct drawbacks as well. There were limitations in drainability, cleanability, durability, etc as well as issues with excessive odor from urine absorbing into the infill material.

Finally, one day, we asked the question – “How could we improve a synthetic grass product for use with dogs?” The pursuit of this answer sent us on a 10-month journey – the end result being K9Grass.

We changed everything. We made it knitted, to create the unique flow-through backing. We added AlphaSan, an antimicrobial agent, to protect the yarn from stains and odors associated with bacteria. The knitted construction enabled us to achieve a density not possible through tufting (the common turf construction), which eliminates the need for infill. The durability and construction makes it completely washable.

In short, K9Grass is a truly unique product that is unmatched in the industry. It was developed to specifically meet and fill a need in the marketplace, and was developed with specific thought and intent. What it is not is a label slapped on a common turf product. Today, you can find any number of products claiming to be “for dogs”, but don’t be fooled by the label. Look to the construction of the product. Look to the integrity of the company behind it. Look to K9Grass.



**K9Grass - The artificial grass designed specifically for dogs!**

ForeverLawn<sup>®</sup>  
INC.

Grass Without Limits.

Visit [www.foreverlawn.com](http://www.foreverlawn.com)

Copyright 2011 ForeverLawn. All Rights Reserved. [\[Contact ForeverLawn\]](#)



by ForeverLawn

Product

Photo Gallery

Installation Process

Featured Projects

Safety

K9Grass Mats

K9Grass Profile

Contact Us

News

## SAFETY

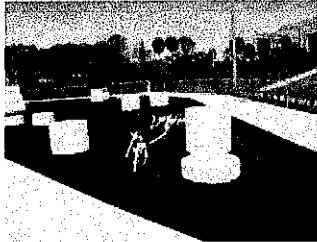

### Fact Sheet: K9Grass is Safe for Pets and the Environment

Our goal at ForeverLawn is creating environments that improve the health and welfare of people and their pets. We take safety very seriously and we are proud to be a leader in the industry by offering a cleaner safer environment in K9Grass with its antimicrobial protection.

We are often asked about the safety of K9Grass and its components, and we are pleased to offer the following data to support our safety claims. Below is a list of questions that we have received:

#### **1. Is K9Grass new and untested, or has it been around for a while?**

K9Grass was introduced in 2005, and from 2005 through 2011 more than 1.4 million square feet of K9Grass has been installed throughout the country in pet facilities, dog parks, and homes, including [Nestle-Purina](#), [Best Friends Pet Care at Walt Disney World](#), [LA Dogworks](#), [The Barkley Pet Hotel & Day Spa](#), and the [Curtis-Hixon Dog Park](#) in Tampa, Florida, to name a few. The early success of K9Grass was accompanied by a great deal of excitement and media attention, including [this article in USA Today](#), which appeared in April, 2007. One of the first large-scale K9Grass projects was the [Saratoga Creek Dog Park](#), a 14,000-square-foot dog park in San Jose, California, that is still enjoyed today by local pets and their families. For more examples of K9Grass in the press, visit our [News Page](#).

#### **2. Do dogs like the grass? Is it difficult to train dogs to use K9Grass?**

Dogs love it! When introduced to K9Grass, it is common for dogs to roll, run, and play on it. The City of Tampa released [this video](#) showing a playful pooch taking advantage of the new Curtis-Hixon Waterfront Dog Park that was part of Tampa's redevelopment project (see [another video here](#)). K9Grass offers a cushioned surface that is great for dogs' paws and joints, and a textured blade structure that dogs love to roll over and rub their backs on. When it's time for dogs to do their "business," they readily use K9Grass as a pet potty. The superior drainage present in K9Grass allows for quick and effective rinsing of liquid waste, and the short, textured surface of K9Grass makes solid waste easy to identify and remove quickly. This prompt removal of waste helps keep odors under control.

#### **3. Should I be concerned about lead in the surface?**

Absolutely not. In April 2008, concerns about lead in synthetic turf arose when elevated levels were found in several New Jersey synthetic turf fields. At the time, the lead chromate that was used to promote colorfastness in synthetic turf was encapsulated to prevent it from being readily absorbed by the body or released into the environment. The issue was resolved, and the safety of synthetic turf was validated on July 30, 2008 when the U.S. Consumer Product Safety Commission staff released the results of its study of lead in synthetic turf, and concluded that "young children are not at risk from exposure to lead in these fields." [Here is their full statement](#). In over 40 years there has never been an instance of human illness or environmental damage caused by synthetic turf. Today, synthetic turf is made without lead as a pigment ingredient. This change in the pigment formulations was a

#### **Media Contact:**

Donna Kent  
Marketing Director  
5801 Mayfair Rd., Ste. 4  
North Canton, OH 44720  
phone  
866.212.1925 fax



voluntary and responsible response by the synthetic turf industry to the CPSC's request of all industries that lead be removed from all products, if possible.

ForeverLawn has compiled an [extensive library of safety data](#) and references to support safety claims.

**4. Is the antimicrobial agent in the grass a danger to the environment or the park users?**

No. In fact, the antimicrobial agent in K9Grass is provided to increase the cleanliness and safety of the pet environment, and poses no threat to the environment, pets, or people who use the park. AlphaSan® antimicrobial technology from Milliken Chemical is manufactured into the grass blades in K9Grass, and is not toxic, flammable, explosive, or corrosive. [See the full statement from Milliken here.](#) AlphaSan® is used in a wide range of products including hospital apparel, bedding, and wound care, food storage containers, kitchen counters, cutting boards, and more.

**5. Does K9Grass get hot?**

In hot weather, the temperature of K9Grass will be slightly cooler than the surface temperature of concrete or asphalt.

**6. Where has K9Grass been used? Do you have references?**

To see several examples of dog parks and pet facilities that utilize K9Grass, visit our [featured projects section](#) of the website. The City of Philadelphia Parks and Recreation Department recently issued a statement detailing their decision to install K9Grass at the Schuylkill River Park Dog Run, [which can be viewed here.](#) We are happy to provide [our current reference list here.](#) For further information, please [contact us.](#)

**About ForeverLawn**

ForeverLawn provides innovative synthetic grass products to create better landscapes worldwide. In areas where real grass is difficult to grow or maintain—due to high traffic or poor conditions—ForeverLawn offers a natural-looking alternative that is beautiful, functional, and durable. In addition to its landscape lines, ForeverLawn also offers specialty products including SplashGrass, K9Grass, SportsGrass, Playground Grass, and Golf Greens. ForeverLawn—Grass without limits. [www.foreverlawn.com](http://www.foreverlawn.com).

**K9Grass - The artificial grass designed specifically for dogs!**



Grass Without Limits.

Visit [www.foreverlawn.com](http://www.foreverlawn.com)

## INSTALLATION PROCESS

The uniqueness of K9Grass goes beyond the grass to the system we can employ. Our system provides a comprehensive drainage solution that will allow for the maintenance of a clean, safe facility.

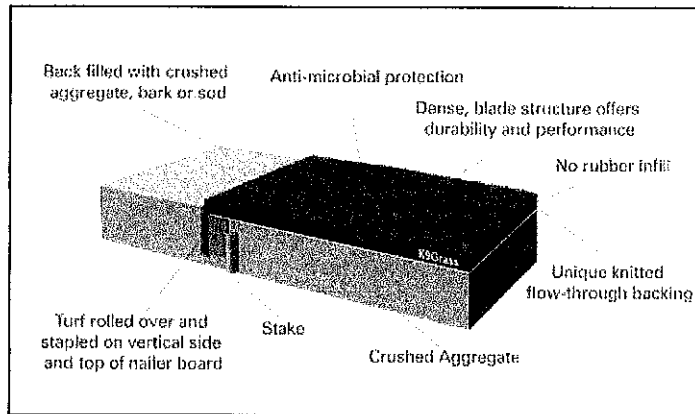

For more information about K9Grass installation options, please download the attached specification sheets:

- [Edging Detail on Aggregate Base \(No Perimeter Curb or Anchor Point\)](#)
- [Edging Detail on Aggregate Base \(Perimeter Curb or Anchor Point\)](#)
- [Edging Detail on Concrete Base](#)

"With the added durability, safety, and cleanliness, K9Grass is in a class by itself. The improved customer satisfaction and lower maintenance and grooming costs also make it a smart business decision."

- Jill Sousa

Citizen Canine

Deluxe Hotel for Dogs

Well, my grass is installed and boy, do I like it! It is easy to care for, and is a BIG improvement over the mulch that I had prior. I am one happy customer.

- Rachel

Limestone Ridge Kennels

"I recently had an opportunity to work with Dave Trotter in having K9Grass installed at Dream Katcher Lodge in Knoxville, TN. My staff and I are extremely pleased with the product, but more than that, I have to tell you how delightful Dave is to work with. Thanks so much for a thoroughly professional experience."

- Mili Bass

DVM

# K9 Grass™

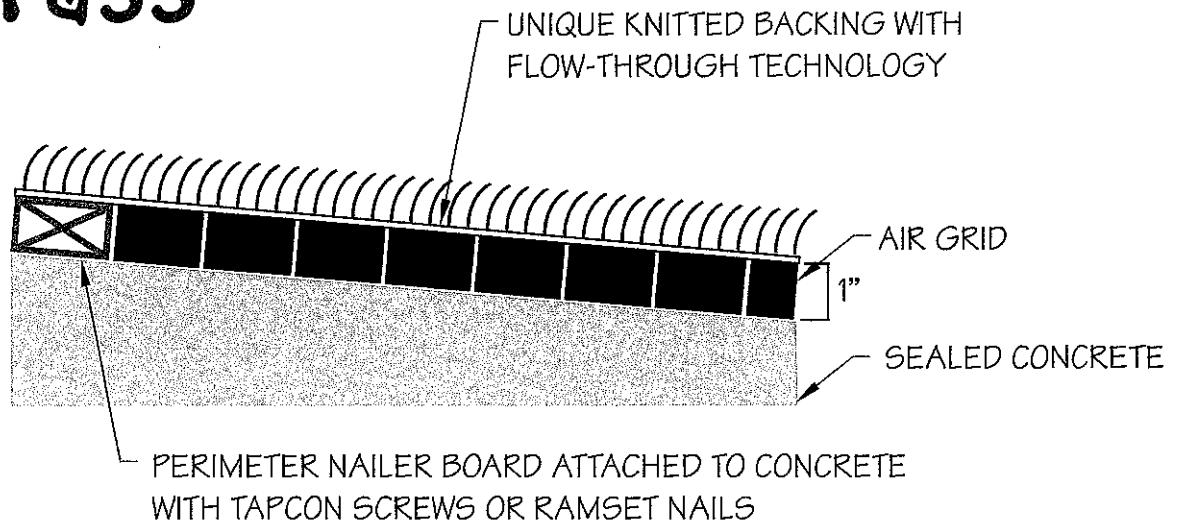

DETAIL #5: EDGING DETAIL ON CONCRETE BASE

# ForeverLawn

INC.

ForeverLawn Inc. 4500 Bogan Avenue NE Albuquerque, NM 87109 Phone: 505.217.0177 Fax: 866.212.1925 www.K9grass.com www.foreverlawn.com	drawn by	name	date
	reference:	T. Smith	12/01/06
	approved by:	quote #	ref dwg
	scale:	Not to Scale	
	drawing no.	DETAIL 5	

# K9 Grass™

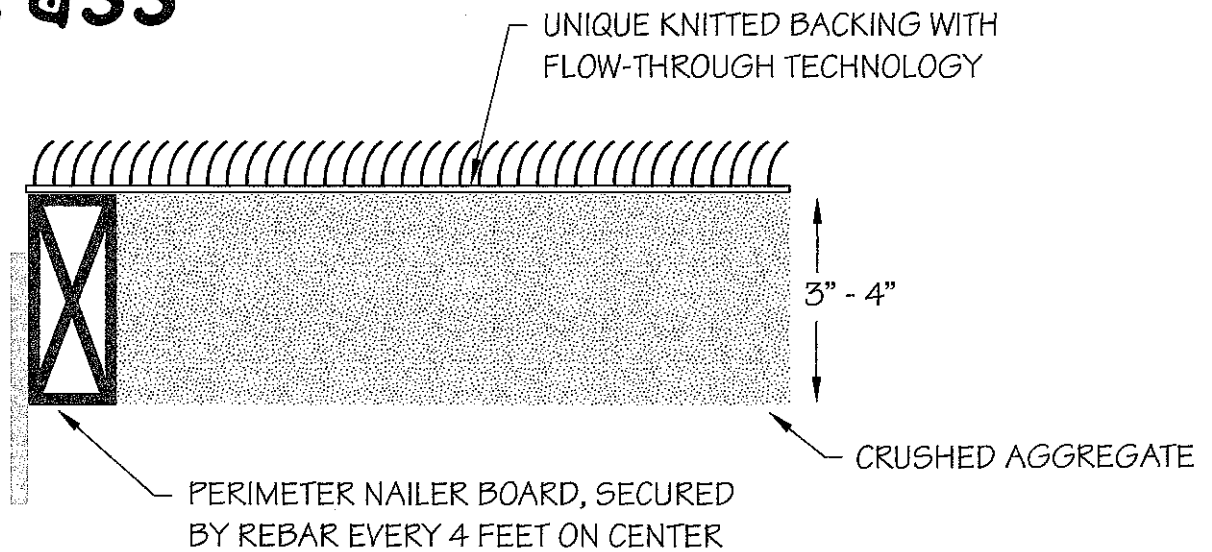

DETAIL #4: EDGING DETAIL ON AGGREGATE BASE  
(NO PERIMETER CURB OR ANCHOR POINT)

# ForeverLawn INC.

ForeverLawn Inc. 4500 Bogan Avenue NE Albuquerque, NM 87109 Phone: 505.217.0177 Fax: 866.212.1925 www.K9grass.com www.foreverlawn.com	drawn by	name T. Smith	date 12/01/06
	reference:	quote #	ref dwg
	approved by:		
	scale:	Not to Scale	
	drawing no.	DETAIL 4	

# K9 Grass™

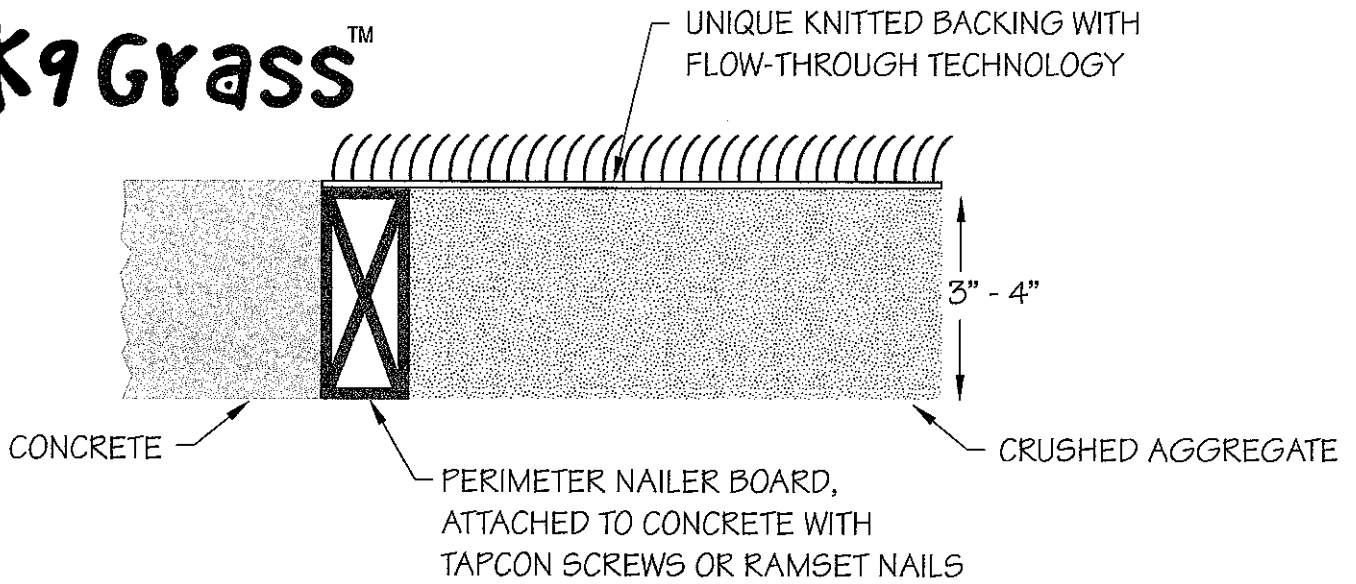

DETAIL #6: EDGING DETAIL ON AGGREGATE BASE  
(PERIMETER CURB OR ANCHOR POINT)

# ForeverLawn INC.

ForeverLawn Inc. 4500 Bogan Avenue NE Albuquerque, NM 87109 Phone: 505.217.0177 Fax: 866.212.1925 www.K9grass.com www.foreverlawn.com	drawn by	name T. Smith	date 12/01/06
	reference:	quote #	ref. dwg
	approved by:		
	scale:	Not to Scale	
	drawing no.	DETAIL 6	

***What Overland Park, KS is doing for dog daycare, boarding and grooming facility?***

Pulled from overland park website – [www.OPkansas.org](http://www.OPkansas.org)



Land Use Lookup	
Land Use Category	Commercial
Land Use	Animal hospitals, large animal veterinarians, or animal kennels
Results	
Special Use	<u>A,RE,R-1,R-1A,R-2,R-3,C-0,C-1,C-2,C-3,M-1,M-2,DD,MS-1,MS-2,SFD,DND,MD,RP-OE,RP-OS,RP-1,RP-1A,RP-1N,RP-2,RP-3,RP-4,RP-5,RP-6,PRN,CP-O,CP-1,CP-2,MXD,CP-3,BP,MP-1,MP-2,MHP</u>

## TITLE 18 - UNIFIED DEVELOPMENT ORDINANCE

---

### 18.110 RULES OF INTERPRETATION AND DEFINITIONS

---

#### 18.110.020 Definitions

---

- A. Where a word or term is not defined in this Chapter but is defined elsewhere in this ordinance or in the Code, such definition shall be applicable unless the context indicates that a standard dictionary definition is more appropriate.
- B. Where a word or term is defined in this Chapter and also defined elsewhere in this ordinance, the definition contained in this Chapter shall be generally applicable except in the Chapter or Section to which the other definition applies.

(History: Ord. ZRR-1725; ZRR-1661; ZRR-1637)

#### 18.110.335 Kennel

---

**Kennel** means a commercial operation that (i) provides food, shelter and care for more than 4 animals of 6 months of age or older for purposes not primarily related to medical care (a kennel may or may not be run by or associated with a veterinarian), or (ii) regularly engages in the breeding of animals for sale.

(History: Ord. ZRR-1725; ZRR-1661; ZRR-1637)

## TITLE 6 - ANIMALS

---

### 6.09 ANIMAL WELFARE

---

#### 6.09.005 Definitions.

---

Whenever in this chapter the following terms are used, each shall have the meaning respectively ascribed in this section:

- F. **Commercial Animal Establishment** is any pet shop, grooming shop, boarding kennel, animal exhibit, auction, riding school, stable carriage horse service, cattery, kennel, sentry or guard dog service, animal trainer, business keeping animals in stock for retail or wholesale trade or sale, or any establishment providing one or more of the principal activities of the aforementioned establishment.

## **TITLE 6 - ANIMALS**

---

### **6.09 ANIMAL WELFARE**

---

#### **6.09.037 Commercial Animal Establishments.**

---

**Standards:** Any person operating a commercial animal establishment shall keep and maintain the animals, and all structures, pens, or yards, tanks, ponds, or other holding areas in which the animals are kept, in such a manner as to prevent a nuisance or health hazard to humans and to avoid injury and illness to these animals. All holding areas must be properly sanitized so as to keep the animals enclosed therein free of diseases. All such animals shall be provided with a constant supply of wholesome food and water or in lieu of this, the proprietor shall prominently and publicly post and shall follow a schedule for adequate feeding and watering. A schedule shall also be posted for cleaning and maintaining cages and other holding areas at the facility. Any animal that is infected or diseased with an infectious agent shall be immediately isolated in such a manner as to prevent spread of disease to any other healthy animals, and it shall be treated immediately to prevent further condition deterioration or euthanized, and if the owner or keeper fails or refuses to provide for such, the supervisor of animal control may remove each such animal to the animal shelter for disposition. All commercial animal establishments must permit inspection of their records, premises and the animals harbored therein by animal control officers of the City, law enforcement officers, and City officials. Failure to comply with the requirements of this section shall be a violation. A conviction for violation of this section shall result in a fine of not less than \$500 and not more than \$1,000. Each day shall be considered a separate offense.

(History: Ord. DAC-1729 §8, 92)

## TITLE 7 - HEALTH AND SANITATION

---

### 7.08 NOISE

---

**Contents:**

- 7.08.001 Definitions.
- 7.08.002 Unlawful to Cause a Noise Disturbance.
- 7.08.003 Unlawful to Allow a Noise Disturbance; Responsibility for Abatement.
- 7.08.004 Exemptions.
- 7.08.005 Penalties.

#### 7.08.001 Definitions.

---

The following words and phrases when used in this ordinance shall, for the purpose of this ordinance, have the meanings respectively ascribed to them in this section unless otherwise defined in the text of the section.

**Commercial Area**- property zoned C-0, CP-0, C-1, CP-1, C-2, CP-2, C-3, CP-3, CBD, DD, Oxford Township Districts CP-0J, CP-1J, CP-2J, CP-3J (per the March, 1982, Zoning and Subdivision Regulations for Oxford Township), or property operating under a special use permit for a commercial use.

**dB(A)**- A-weighted sound level measured in decibels by a general purpose, properly calibrated, sound level meter complying with the provisions of the American National Standard Institute.

**Emergency Motor Vehicle**- a motor vehicle belonging to a fire department or certified private volunteer firefighter or firefighting association, partnership or corporation, an ambulance, or a motor vehicle belonging to a federal, state, county or municipal law enforcement agency, provided such vehicle is being used as an emergency vehicle by one authorized to use such vehicle for that purpose.

**Industrial Area** - property zoned BP, M-1, MP-1, M-2, MP-2, and Oxford Township Districts IP-1J and IP-2J (per the March, 1982, Zoning and Subdivision Regulations for Oxford Township).

**Plainly Audible**- capable of being heard. It is not necessary to distinguish words or melodies. A plainly audible sound may consist of bass alone.

**Property Owner**- the named property owner as indicated by the records of the Register of Deeds or Appraiser's Office in Johnson County, Kansas.

**Residential Area**- property zoned RE, R-1, RP-1, R-1A, RP-1A, R-2, RP-2, R-3, RP-3, RP-4, R-5, RP-5, R-6, RP-6, former District R-4, and Oxford Township Districts RR, R-1A, R-1B, R-2, R-3 and R-4 (per the March, 1982, Zoning and Subdivision Regulations for Oxford Township) or property upon which a legal non-conforming residential use is operating.

**Sound Amplification or Producing Device or Similar Equipment**- shall mean radio, radio receiving set, television, phonograph, stereo, tape player, cassette player, compact disc player, "boom box," loudspeaker, drum, juke box, nickelodeon, musical instrument, sound amplifier or other device which produces, reproduces, or amplifies sound.

**Tenant**- any person who has an interest in real property either by oral or written lease or covenant.

(History: Ord. NOI-2287 §1, 2001)

**7.08.002 Unlawful to Cause a Noise Disturbance.**

It shall be unlawful to make or cause to be made a Noise Disturbance within the City. A Noise Disturbance shall include any or all of the following:

- A. A sound registered on a decibel meter from any source not exempted or otherwise regulated by this Chapter and which, when measured anywhere off of the property of the sound source, is in excess of the dB(A) established for the time period and zones listed below.

AREA	7:00 a.m. – 10:00 p.m.	10:00 p.m. – 7:00 a.m.
Residential	60 dB(A)	55 dB(A)
Commercial	65 dB(A)	60 dB(A)
Industrial	70 dB(A)	65 dB(A)

- B. The owning, keeping or harboring of any animal that howls, barks or emits audible sounds, without provocation of the complainant, that are unreasonably loud or disturbing which are of such character, intensity and duration as to disturb the peace and quiet of a reasonable person in the neighborhood or to be detrimental to the life and health of any individual.
- C. A sound resulting from the erecting, constructing, excavating, demolishing, altering or repairing of any structure, or operating, or permitting the operation of any tools or equipment used in construction, drilling, or demolition work in such a manner as to cause a sound Plainly Audible across any property boundary line between the hours of 9:00 p.m. and 7:00 a.m. Between the hours of 7:00 a.m. and 9:00 p.m., this activity shall not be subject to the time, area and dB(A) limits set forth in subsection A.
- D. The repairing, rebuilding, modifying or stationary testing of any motor vehicle, motorcycle, or motorboat in such a manner as to cause a sound Plainly Audible across any property boundary line between the hours of 10:00 p.m. and 7:00 a.m. Between the hours of 7:00 a.m. and 10:00 p.m., this activity shall not be subject to the time, area and dB(A) limits set forth in subsection A.
- E. The operating or occupancy of a vehicle, which is moving or stationary, standing or parked, whether persons are seated in the vehicle or not, from which any Sound Amplification or Producing Device or Similar Equipment is creating a sound that is Plainly Audible at least fifty (50) feet from the source of the sound.\* A violation of this subsection shall be a traffic offense.
- F. The operation of any power tool, garden tool, lawnmower, snow blower or other similar equipment or device in Residential Areas in such a manner as to cause a sound Plainly Audible across any property boundary line between the hours of 10:00 p.m. and 7:00 a.m. Between the hours of 7:00 a.m. and 10:00 p.m., this activity shall not be subject to the time, area and dB(A) limits set forth in subsection A.
- G. The operating, playing, permitting or causing to be operated or played any Sound Amplification or Producing Device or Similar Equipment in a manner as to cause a sound Plainly Audible

across any property boundary line between the hours of 12:00 a.m. (midnight) and 6:00 a.m. Between the hours of 6:00 a.m. and 12:00 a.m. (midnight), this activity is subject to the area and dB(A) limits set forth in subsection A above.

\*As to vehicle equipment and maintenance and prevention of excessive or unusual noise therefrom, see OPMC 12.04.175(a).

(History: Ord. NOI-3051 §1, 2014; NOI-2772 §1, 2008; NOI-2373 §1, 2002; NOI-2287 §2, 2001)

### **7.08.003 Unlawful to Allow a Noise Disturbance; Responsibility for Abatement.**

- A. It is unlawful for any Property Owner or Tenant, or other person with control, occupancy, or possession of residential property, to allow or permit a person or group of persons to create a Noise Disturbance as defined in subsections A through G of Overland Park Municipal Code Section 7.08.002 on said property.
- B. The Property Owner, Tenant or other such person with control, occupancy, or possession of property, shall be responsible for abatement of Noise Disturbances occurring on that property and failure to do so shall be a violation of this section.

(History: Ord. NOI-2310, §1, 2001; Ord. NOI-2287, §3, 2001)

### **7.08.004 Exemptions.**

The following shall not be considered to be Noise Disturbances for purposes of this ordinance:

- A. Sound from law enforcement motor vehicles and other Emergency Motor Vehicles including, but not limited to, snow-clearing equipment.
- B. Sound from vehicles or equipment belonging to the city, state, county, federal government, school or other governmental agencies or utilities engaged in preparing for or remedying a potentially hazardous situation.
- C. Sound that a person is making or causing to be made when said person has received and maintains a valid license or permit which specifically allows sound levels in excess of those set forth in this ordinance from any department, board or commission of the City authorized to issue such license or permit.
- D. Sound originating from private property, provided that such property was annexed into the City by either Ordinance No. A-2367 or Ordinance No. A-2719.

(History: Ord. NOI-2696 §1, 2008; NOI-2402 §1, 2002; NOI-2373 §2, 2002; NOI-2291 §1, 2001; NOI-2287 §4, 2001)

### **7.08.005 Penalties.**

- A. Upon a first conviction for a violation of this chapter, the Court shall assess a fine of no less than fifty dollars (\$50.00). Upon a second conviction, the Court shall assess a fine of no less than one hundred fifty dollars (\$150.00). Upon a third or subsequent conviction, the Court shall assess a fine of no less than two hundred fifty dollars (\$250.00). No prior conviction shall be considered

in determining the penalty to be assessed if twenty-four (24) months have elapsed between the date of the violation and the date of the conviction next immediately preceding the sentencing date.

- B. No person shall be eligible for a parole, suspension or reduction of any part of said fine except that that portion of any fine or combination of fines that exceeds two hundred dollars (\$200.00) assessed from the same set of operative facts may be suspended for twelve (12) months on the condition the violator have no further violations of the noise ordinance during that period. In addition to any such fine imposed, the Court may impose a jail term of up to six (6) months.
- C. Each occurrence of a violation, or in the case of a continuous violation, each day a violation occurs or continues, constitutes a separate offense and shall be punishable as such hereunder.

(History: Ord. NO1-2287 §5, 2001)



## TITLE 18 - UNIFIED DEVELOPMENT ORDINANCE

---

### 18.370 SPECIAL USES

---

**Contents:**

- 18.370.010 Statement of Intent
- 18.370.020 Special Uses Designated
- 18.370.030 Special Uses Not Permitted
- 18.370.040 Development and Performance Standards
- 18.370.050 Revocation of Special Use Permits

#### 18.370.010 Statement of Intent

---

Certain uses of land or buildings may not be appropriate under all circumstances in any zoning district, but may be appropriate where adequate precautions can be taken to assure the compatibility of the use with surrounding uses. It is the intent of this Chapter to allow for such uses by the granting of a special use permit, subject to the same procedures applicable to a rezoning. (History: Ord. ZRR-2795 §6, 2009; ZRR-1725; ZRR-1637)

#### 18.370.020 Special Uses Designated

---

Any building, structure, land or premises may be used, and any building or structure may be erected, constructed, reconstructed, moved or altered, for one (1) or more of the following special uses, subject to approval of a special use permit by the Governing Body and subject to the development and performance standards set forth in Section 18.370.040: <sup>1</sup>

- A. Airports or aviation fields, heliports and helicopter landing pads.\*
- B. Asphalt plants, concrete plants and foundries.
- C. Assembly halls, community centers or convention centers.
- D. Utility structures including outdoor storage areas accessory to a utility maintenance facility.
- E. Cemeteries, mausoleums or crematories for the disposal of the dead.
- F. Clubs and drinking establishments.\*
- G. Day care homes, group day care homes, child care centers, preschools or Mother's Day Out programs (which are not otherwise permitted as an accessory use or as a permitted use). \*
- H. Drive-in theaters.
- I. Group boarding homes for minors or group boarding homes for adults.
- J. Hospitals, nursing or convalescent homes, and continuing care community.
- K. Hotels, motor hotels or motels.

- L. Keeping of farm animals such as horses, ponies, cows and chickens on a lot or tract of less than three acres in size.
- M. Animal hospitals, large animal veterinarians, or animal kennels.\*
- N. Mines or quarries (including the removing, screening, crushing, washing or storage of ore, sand, clay, stone, gravel or similar materials).\*
- O. Nurseries, greenhouses and buildings or areas for the wholesale or retail sale of landscaping supplies, plant materials or landscape maintenance services.
- P. Off-street parking lots/structures of a temporary or permanent nature.
- Q. Oil or gas drilling or production.\*
- R. Outdoor advertising (poster panels, billboards, recreational sponsor signs or off-site promotional signs).\*
- S. Penal or correctional institutions.
- T. Radio, television, microwave.
- U. Communications facilities, towers and antennas.\*
- V. Reservoirs, towers, filter beds or water treatment plants.
- W. Residential real estate sales offices.\*
- X. Sales and display areas for manufactured homes, mobile homes or modular housing.
- Y. Solid waste disposal facilities or sanitary sewage plants.
- Z. Sports or recreation facilities of all types, private.
- AA. Taverns and dance facilities.
- BB. Amusement centers and arcades.\*
- CC. Temporary use of land for commercial or industrial purposes.\*
- DD. Churches, elementary and secondary schools, and publicly-owned and operated community buildings, museums and libraries.
- EE. Retail sale of building supplies, with outside storage in excess of 20 percent (20%) of the ground floor area of the building in a CP-2 District.\*
- FF. The sale, leasing, rental and servicing of construction equipment and farm machinery.
- GG. Contractor's yard and storage.
- HH. Motor vehicle tow lots (but not salvage yards).
  - B. Sale of used passenger cars in conjunction with either a new car dealership or a qualified rental car agency.\*
- JJ. Indoor self-storage facilities.\*
- KK. Transportation facilities for public agencies (including but not limited to, school districts, municipal or public transportation agencies, and public utilities).\*
- LL. Car wash.\*

MM. Wind turbine(s).\*

NN. Municipal Facilities.

OO. Uses previously authorized by conditional use permits issued by Johnson County for properties in the areas annexed by Ordinance No. A-2367 (effective May 8, 2002) or Ordinance No. A-2719 (effective March 13, 2008).\*

(History: Ord. ZRR-3044 §1, 2014; ZRR-2968 §1, 2012; ZRR-2952 §1, 2012; ZRR-2836 §14, 2010; ZRR-2828 §1, 2009; ZRR-2684 §1, 2007; ZRR-2650 §3, 2007; ZRR-2491 §2, 2004; ZRR-2262 §14, 2001; ZRR-2180 §1, 99; ZRR-2152 §1, 99; ZRR-2079 § 1, 97; ZRR-2004 § 9,96; ZRR-1977 §1,96; ZRR-1916 §2,95; ZRR-1829 §1,94; ZRR-1725; ZRR-1637; ZRR-1477 §1; ZRR-1447 §4; ZRR-1429 §8; ZRR-1304 §11; ZRR-1237 §7; ZRR-1166 §1; ZRR-1106 §1; ZRR-900 §1; ZRR-889 §18.36; ZRR-813 §5; ZRR-412-32; ZRR-412 §20)

1. All special uses are subject to the development and performance standards in Section 18.3.70.040 A. Special uses with additional specific development and performance standards in Section 18.3.70.040 are marked with a "\*".

### **18.370.030 Special Uses Not Permitted**

It shall be presumed that any use listed in Section 18.370.020 shall not be permitted in the City without a special use permit unless that use is also specifically listed as a use permitted by right or as an accessory use in a given zoning district.

(History: Ord. ZRR-2795 §7, 2009; ZRR-1725; ZRR-1637)

### **18.370.040 Development and Performance Standards**

#### **A. Development and performance standards applicable to all special uses.**

1. At the time of approval of any special use permit, the Governing Body may impose such restrictions as to height or bulk of buildings or structures, yard and lot area requirements, parking requirements, open space or landscaping requirements, fencing requirements or other requirements determined to be reasonably necessary for the protection of the public health, safety and welfare of the neighborhood and the community at large. Further, the Governing Body may require that the applicant submit a final development plan for approval by the staff, Planning Commission or Governing Body prior to the issuance of any building or site development permit.
2. Except where a longer or shorter time has been stated for a specific special use, and except as provided below, the maximum time period for any special use permit, or any extension thereof, shall be ten (10) years. In cases of extreme hardship, the Governing Body may consider granting a permit, or extension thereof, for such period as is warranted under the circumstances.
3. Renewal of a special use permit is not a matter of right. The same discretion shall attach to a decision to renew a special use permit as existed in the original decision to grant or deny that permit; provided, however, that in considering the decision to grant or deny renewal, any factor which would be relevant to consideration of revocation shall also be relevant to consideration of renewal.

**B. Airports or aviations fields.**

At the time of approval of any permit for an airport or aviation field, the Governing Body may impose such restrictions on land, buildings or structures within an approach or transition plane or turning zone as is necessary to promote safety of navigation and to prevent undue danger from confusing lights, electrical interference or other hazards.

**C. Amusement centers and arcades.**

1. The initial special use permit may be granted for a period of up to twelve (12) months, with renewals for a period of up to five (5) years. The Planning Commission and Governing Body may, upon a finding that time restrictions on the permit are not required to protect the public health, safety and welfare, approve an indefinite special use permit for an indoor amusement center and arcade located within an enclosed shopping mall in excess of 400,000 square feet.
2. All facilities shall comply with the requirements contained in 5.24 of the Code.
3. On-site parking shall be provided at the rate of one parking space for each two occupants, to be calculated by building code standards. Parking shall be available to be assigned solely to the proposed establishment and cannot be counted for other establishments, except that for shopping centers in excess of 400,000 total square feet the provisions of Section 18.430.140 for shared parking may be applied.
4. All facilities shall provide enclosed trash structures either inside or outside of the facility of sufficient size to adequately and sanitarily contain all trash produced by the facility. The management shall be responsible for the policing of all trash associated with the operation of the facility.

**D. Clubs and drinking establishments.**

1. No permit shall be approved unless a determination is made that the impacts of traffic, access and parking, noise and litter will not adversely affect the surrounding neighborhood.
2. An initial permit may be issued for a maximum time period of three (3) years. Subsequent renewals may be issued for a maximum time period of five (5) years. Provided, however, that establishments within facilities such as convention centers, hotels, motels, or similar structures determined not to have traffic, parking, noise, litter or other adverse impacts on surrounding properties, may be issued a special use permit for an indefinite time period.

**E. Day care homes, group day care homes, child care centers, preschools or Mother's Day Out programs (which are not otherwise permitted as an accessory use or as a permitted use).**

1. The property must be zoned District A or residentially zoned property.
2. The day care operation must have been in existence continually since January 16, 1984. Alternatively, a day care operation in an area annexed by Ordinance No. A-2367 (effective May 8, 2002) or Ordinance No. A-2719 (effective March 13, 2008) may be issued a special use permit under this provision if the day care operation was previously authorized by and operating in compliance with a conditional use permit issued by Johnson County, and the

conditional use permit (or subsequent special use permit) has not been expired for a period of time exceeding six (6) months.

3. The day care operation shall be licensed or registered with the State of Kansas and shall comply with all applicable standards set out in Section 18.390.140 B of these regulations. Where the public hearing process clearly indicates that no parking, traffic generation, noise or other adverse impacts are resulting from the facility, the Planning Commission and Governing Body may waive the performance standards referenced above. The Planning Commission and Governing Body may, as a part of any special use permit renewal, require that the number of children and/or

employees be reduced until, in their judgment, the adjoining properties are not adversely impacted.

4. Where the day care operation is operated from a residential dwelling, the owner or operator shall occupy the structure as his or her private residence.
5. No signs identifying the daycare operation shall be permitted on the premises.

**F. Mines or quarries (including the removing, screening, crushing, washing or storage of ore, sand, clay, stone, gravel or similar materials).**

1. Mines or quarries shall be subject to the development and performance standards set forth in Section 18.310.050 (District M-2).
2. All mines or quarry operations shall be located adjacent, or have direct access over a private haul road, to a thoroughfare capable of handling the expected loads of heavy truck traffic.
3. All above-ground operations shall be located not less than 400 feet from the property line of adjoining commercial or industrial property, 750 feet from the property line of adjoining agricultural or residentially zoned property, and not less than 1,000 feet from the nearest residence existing at the time of commencement of operations.
4. All below-ground operations shall be located not less than 200 feet from the nearest property line, measured laterally.
5. The initial special use permit may be issued for a maximum time period of ten (10) years, with subsequent renewals issued for a maximum time period of five (5) years.

**G. Oil or gas drilling or production.**

1. Special use permits for oil or gas drilling or production may be approved provided that the approval is consistent with the intent and purpose of 5.51 of the Code as well as the spirit and intent of this Title. In the event of a conflict between the definitions or terms of this Section and 5.51, the provisions of 5.51 shall control.
2. In addition to the criteria stated in Section 18.370.040, the Planning Commission and Governing Body shall consider the following criteria in reviewing an application for an oil or gas special use permit:
  - a. The development of the natural resources as it relates to the local, regional or national economy.
  - b. The economic conditions as they affect other types of development.

- c. The effect of approval of the special use permit on existing and future development or development potential of the property.
  - d. The cumulative effect of approval of the proposed permit and other oil and gas special use permits on existing and future development or development potential of the area.
  - e. Past history of the operator with regard to spills, overall safety and compliance with local or state laws.
3. The minimum tract size for special use permits for oil drilling or production shall be ten (10) acres, including any public street right-of-way. The applicant shall have the written authorization of all owners of the tract. There is no minimum tract size for special use permits for gas drilling or production.
4. No portion of the drilling area shall be closer than 165 feet from any point along the tract line or from public street right-of-way. No drilling or production related activities shall occur within this required buffer area.
5. The maximum depth of any well shall be 1,200 feet below grade unless a greater depth is authorized at the time of the permit approval.
6. In addition to the aforementioned requirements, additional information or conditions may be required, as deemed necessary and proper to protect and promote the public health, safety and welfare, and which requirements are consistent with the intent and purpose of this Chapter, including but not limited to the following:
  - a. Enclosure or burial of the wellhead and/or appurtenances.
  - b. Material types and height of any fencing.
  - c. Noise suppression devices or procedures.
  - d. Hours of operation for drilling equipment delivery, drill pipe storage, racking, servicing, loading of oil, removal of equipment, perforating or fracturing and restoration.
  - e. Routes used by drilling or production related vehicles.
  - f. The capacity number and color of storage or other tanks.
  - g. An environmental impact assessment addressing those areas about which the Planning Commission or Governing Body require additional information, such as noise pollution, water pollution, air pollution, geological impacts or safety and nuisance potential. Any such environmental impact assessment shall include baseline data against which actual impacts may be evaluated and shall also include the reasonable and preferred procedures and/or equipment for mitigating or abating any and all significant impacts. Any such environmental impact assessment shall be prepared and certified by a professional qualified in the field(s) to which the assessment applies.
  - h. Fiscal impact analysis.
7. Any oil or gas drilling or production operation shall comply with the development and performance standards set forth in Section 18.310.050 (District M-2).

8. An initial special use permit for oil or gas drilling or production may be granted for a period of up to ten (10) years, but in no case shall the period granted be less than five (5) years. All subsequent special use permits may be granted for renewal periods of up to ten (10) years, but in no case shall the period granted be less than one year. A special use permit granted for gas production only may be granted for an indefinite period of time.
9. The granting of a period for oil or gas drilling or production shall not be construed, nor interpreted as implying, that refineries or dehydration or absorption plants are permissible within the permit. Storage tank farms not accessory to the production for which the special use permit has been granted shall not be permitted.

#### H. Outdoor advertising.

##### 1. Billboards (including poster panels).

- a. **Zoning:** Billboards may be located on property zoned M-1, Industrial Park District, and M-2, General Industrial District, which has frontage on Interstate-35, Interstate-435 or Interstate-635, provided all other conditions of this Chapter are met.
- b. No billboard shall be located within the following areas, whichever is more restrictive:
  1. Within 400 feet of the property line of any residentially zoned property, park, playground, school, hospital or church. Such measurements shall be made as a 400-foot linear measurement along the street frontage on which the billboard is located.
  2. Within 200 feet of the property line of any residentially zoned property, park, playground, school, hospital or church. Such measurements shall be made as a 200-foot radial distance 360 degrees around the location of the proposed billboard.
  3. A billboard located within a parking lot shall not cause a reduction in the number of required parking spaces, nor be located so as to interfere with normal circulation patterns.
- c. **Spacing:** All billboards shall maintain a minimum spacing of 1,200 feet from existing billboards along interstate or adjacent frontage road rights-of-way. The 1,200 spacing dimension shall be measured along the side of the roadway where the sign is proposed regardless of the direction from which the sign may be viewed. All billboards existing within the City at the time of the adoption of this ordinance shall be used as the beginning point for such 1,200 foot minimum spacing measurements.
- d. **Size and Shape:** No billboard within the City shall exceed 672 square feet in size. The shapes of all proposed billboards shall comply with representations shown on Exhibit "A" attached to Resolution No. 2907. Deviations from the standard billboard shapes represented in said Exhibit "A" shall not be permitted.
- e. **Height:** No billboard shall exceed thirty (30) feet in height above the right-of-way grade from which it is viewed. In cases where the grade at the location of the proposed billboard is higher than the right-of-way grade adjacent to which it is located, the Planning Commission and Governing Body may require the overall height of the billboard to be lowered.

- f. **Lighting:** All billboards shall be indirectly illuminated or nonilluminated and comply with all building codes of the City. Billboards may be lit only from dusk to 12 a.m. midnight.
- g. No billboard shall be permitted to be mounted, attached or affixed to a building rooftop or the walls of any building.
- h. All billboards shall maintain the required front yard building setback from adjacent right-of-way equal to that required of any structure built within the zoning district in which the billboard is located.
- i. The area around any billboard and its supports shall be kept clear of debris, and all scrub brush, tall grass and weeds shall be cleared away to a distance of a ten (10) foot radius from the billboard and supports.
- j. Any landscaping approved as part of a special use permit allowing a billboard shall be replaced to original species and size during the next appropriate planting season.
- k. No more than one double-faced billboard shall be permitted per pole and/or location for which a special use permit is approved.
- l. No special use permit for any billboard shall be granted for more than three (3) years, with a sixty (60) day time limit for removal in the event the permit is not renewed.

## 2. Off-site promotional signs.

- a. Off-site promotional signs for developments may be permitted for each project of up to ten (10) acres in area. For projects of more than ten (10) acres, one off-site promotional sign for each additional twenty (20) acres or portion thereof shall be permitted. No project shall have more than three such signs. A project shall mean a unit of development under one development plan, one financing package and one identifying name. An entire residential subdivision shall be deemed a project even though several builders may be involved.
- b. Off-site promotional signs shall be permitted for a maximum period of three years, beginning with the issuance of the first building permit on the project. Such signs shall be removed immediately upon termination of the three (3)- year period regardless of the extent of project completion or occupancy.
- c. Projects constructed in phases shall be considered as only one project with respect to the three (3)- year limitation, except that in the case of a division into two (2) or more developments, each having a separate owner-developer financing status, each development shall be considered a project.
- d. Off-site promotional signs shall be limited to single-family subdivisions, duplex and apartment or townhouse complexes.
- e. Off-site promotional signs may have a maximum height of 11 feet, maximum length of 16 feet, may be flood-lighted and shall be well-designed and maintained throughout the life of the sign.

## 3. Recreational sponsor signs.



- a. Signs shall be permitted only on the inside surface of the perimeter fencing around an athletic field or on a scoreboard associated with an athletic field. The placement of all signs shall be in accordance with a sign plan, approved by the Governing Body as part of the special use permit, which indicates the location and approximate height of all potential signs.
- b. Signs shall be oriented toward the playing field so that they are visible to participants and spectators, and shall not be positioned so that they can be readily viewed from surrounding streets or adjacent properties.
- c. Signs shall not be illuminated except when the playing field or scoreboard is in use.
- d. Sign permits shall not be required.

**I. Residential real estate sales offices.**

Real estate sales offices which are not otherwise a permitted use in a residential subdivision or project, may be operated under a special use permit for the purpose of selling properties located within the subdivision or project under such conditions as may be imposed at the time of approval of the permit. No such permit shall be issued for a period exceeding two (2) years. The precise location of any such real estate sales office within the subdivision or project shall be indicated on the application for the permit.

**J. Taverns and dance facilities.**

1. No permit shall be granted unless the distance between the walls of the facility within which the operation is located and the property line of the nearest residentially zoned property is in excess of 200 feet.
2. On-site parking shall be provided at the rate of one (1) parking space for each two (2) occupants, to be calculated by building code standards. Parking shall be available to be assigned solely to the proposed establishment and cannot be counted for other establishments except in the case of shopping centers in excess of 300,000 total square feet. The Governing Body may as a part of the required special use permit approve shared parking not solely available to the facility provided the following criteria are met:
  - a. The shared parking shall not exceed more than fifty percent (50%) of the total required parking;
  - b. The business that parking is shared with shall be closed during any period of the day that such shared parking is being used to meet the requirements for an increased occupant load as specified in the special use permit;
  - c. Legal documentation acceptable to the City ensuring the facility's ability to have access to the shared parking for the term of the proposed special use permit shall be submitted with the application;
  - d. All shared parking shall be located on property abutting the land containing the facility;
  - e. The facility shall be posted with two alternate occupant loads, which shall specify the hours when each load is in effect. The first load shall be based on the parking solely available to the facility. The alternate load shall be based on the parking solely available to the facility, together with the shared spaces.

3. All facilities shall provide enclosed trash structures either inside or outside of the facility of sufficient size to adequately and sanitarily contain all trash produced by the facility. The management shall be responsible for the policing of all trash associated with the operation of the facility.
4. The initial special use permit may be granted for a period of up to twelve (12) months, with renewals for one- (1) year periods thereafter provided all standards of performance are being met.
5. Taverns shall also be subject to the requirements contained in 5.12 of the Code.

**K. Temporary uses of land for commercial or industrial purposes.**

Special use permits for temporary uses of land for commercial or industrial purposes may be granted for a period not to exceed two (2) years, subject to renewal for one or more periods of time not to exceed a maximum of two (2) years for each renewal. Any stored equipment or material shall be removed from the site on the date of expiration of the special use permit. This provision shall not be used as a means of seeking approval for occupations which are not permitted as accessory uses in residential districts under 18.390.

**L. Retail sale of building supplies, with outside storage in excess of 20 percent (20%) of the ground floor area of the building in a CP-2 District.**

Approval or disapproval shall be based on the following criteria in addition to the criteria specified in Section 18.140.150 E:

1. The compatibility of the open storage area to the surrounding or proposed land use of adjacent properties.
2. The size of the open storage area in relation to the size of the main retail structure.
3. The amount of storage area under roof.
4. The amount, type, and quality of screening of the open storage area.
5. The ability of emergency vehicles to enter and maneuver through the site.

**M. Communications facilities, towers and antennas.**

1. The definitions in Section 18.395.020 shall apply to Special Use Permits for communications facilities.
2. Each application for a special use permit for a communications tower shall follow the process and submit the required information listed in Section 18.395.050.
3. A request for a Special Use Permit for a communications facility shall use the location criteria in Section 18.395.060.
4. A Special Use Permit for a communications facility shall be subject to the performance standards listed in Section 18.395.070.
5. An initial request for a Special Use Permit shall be limited to five (5) years. At the time of renewal the applicant shall demonstrate, to the satisfaction of the City, that a good faith effort has been made to cooperate with other communications service providers to establish co-location at the facility. Good faith effort shall include, but is not limited to, timely response

to co-location inquiries from other providers and sharing of technical information to evaluate the feasibility of establishing co-location. Failure to demonstrate that a good faith effort has been made may result in the denial of the request for renewal.

**N. Sale of used passenger cars in conjunction with either a new car dealership or a qualified rental car agency.**

1. For the purposes of this Chapter:
  - a. A "new car dealership" must be a licensed "new vehicle dealer" under the laws of the state of Kansas (K.S.A. 8-2401 (b) as may be amended).
  - b. A "qualified rental car agency" is defined to mean a company whose primary business objective is the rental of passenger cars to the general public in multiple (more than two states and whose used car inventory consists predominantly of the company's former rental car inventory).
2. The property must be zoned District CP-2, C-2 or DFD.
3. Used car facility size limitation.
  - a. In the case of a new car dealership, the net site area of the used car facility shall not exceed 50 percent (50%) of the net site area of the new car dealership.
  - b. In the case of a qualified rental car agency, the net site area of the used car facility shall be less than the net site area of the qualified rental car agency. Accordingly, the portion of the net site area dedicated for the used car facility shall be less than 50% of the overall net site area; and the net site area of the rental car operation shall be in excess of fifty percent (50%) of the overall net site area. In order to maintain this limitation, the special use permit may set a cap on the number of used cars allowed on the site at any given time.
4. Proximity.
  - a. In the case of a new car dealership, the property line of the used car facility must be within 300 feet of the property line of the associated new car dealership.
  - b. In the case of a qualified rental car agency, the two businesses shall either be located on the same property or the property line of the used car facility must be directly contiguous to the property line of the rental car facility.
5. A site plan must be submitted which clearly defines the location of all used car display areas, new car display areas (if any), rental car display areas (if any), and employee and customer parking.
6. The used car facility must be licensed to the same person as the applicable new car dealership or qualified rental car agency, or to said person's affiliate, defined as a wholly owned parent or subsidiary or as an entity under common ownership or control.
7. All signage for the used car facility will be requested and approved with the special use permit application.

- a. In the case of a new car dealership, the used car facility must use, and maintain on all signage, the same trade name and the same manufacturers' brand name as the new car dealership, with the additional option of the words "used cars" or their equivalent.
  - b. In the case of a qualified rental car agency, the used car facility must use, and maintain on all signage, the same trade name as the qualified rental car agency, with the additional option of the words "used cars" or their equivalent. In addition, there shall be no use of attention-attracting devices, pennants or streamers; except where a Special Event Permit specifically allowing such devices has been obtained.
8. In the case of a new car dealership, the operation of the used car facility must be governed by an agreement with the same first or second stage manufacturer or distributor as the new car dealership. (This requirement does not apply to qualified rental car agencies.)
  9. Documentation of compliance with these performance standards must be submitted with the application for a special use permit.
  10. The initial special use permit may be for a period up to ten (10) years. Any subsequent renewals may be for a period up to ten (10) years. Criteria for said renewals shall include, but not be limited to, whether or not the maintenance and appearance standards, and the manner of display of vehicles, of the used car facility have been equal to or greater than the associated new car dealership or qualified rental car agency.

**O. Animal hospital** means a building or group of buildings used primarily for providing acute or emergency in-patient services within a completely enclosed building for the diagnosis, treatment, or medical and surgical care of sick or injured animals operating on a not less than twenty-four (24) hours, seven (7) days a week basis. Such hospitals may include related facilities such as laboratories, out-patient department, and staff offices; provided, however, that such related facilities must be incidental and subordinate to the main use and must be an integral part of the hospital operation and does not include any outdoor facilities such as kennels, non-medical boarding, pet runs and enclosures unless specifically approved as part of the special use permit.

**P. Indoor self-storage facilities**

1. Indoor self-storage facilities shall only be permitted in the C-2, CP-2, C-3 or CP-3 districts.
2. In consideration of the special use permit request, the Planning Commission and Governing Body shall consider the prominence of the proposed location in relation to surrounding commercial development, the potential impact of the storage facility on the character and economic vitality of those surrounding developments, and the appropriateness of the Land Use Intensity Guidelines.
3. The storage facility shall not adversely alter the architectural design of a shopping center, and shall conform to the Shopping Center Design Guidelines.
4. At the final development plan stage, the applicant shall demonstrate that the facility can be converted without major structural changes into a space suitable for a generic retail business.
5. All operations shall be within a fully enclosed climate controlled building. Overhead doors or other means that directly access storage space from outside the building are prohibited.

6. Setbacks shall be provided as required by the underlying zoning district.

**Q. Transportation facilities for public agencies.**

1. Preliminary and final site plan approval shall be required for all transportation facilities. Preliminary and final site plans shall include, but not be limited to, the following: adequate employee parking areas for the facility, parking and storage areas for all buses and other vehicles, structures for administration, maintenance and repairs, and screening of the facility.
2. All parking and vehicle storage areas shall be screened from view from all adjacent public streets and adjacent property. The screening technique and materials are subject to review and approval by the Planning Commission and Governing Body.
3. All maintenance and repair of any vehicles shall be conducted inside of a permanent structure.
4. All inoperable vehicles shall be stored inside a permanent structure or removed from the facility.
5. Transportation facilities shall not have a common property line with property identified as low-density or very-low-density on the City's Future Development Plan map.

**R. Car wash.**

1. A special use permit for a car wash shall only be allowed for property zoned CP-2, Planned General Business District.
2. A car wash shall meet the requirements of the Commercial Design Guidelines and Standards, Site Design Standards, and the Architectural Design Standards.
3. The location for a car wash shall not have a common property line with property identified as low-density-residential or very-low-density-residential on the Future Development Plan Map.
4. A car wash shall be a tunnel type, fully enclosed building. The car wash shall clean a moving vehicle by using employees or by an automated system.
5. All mechanical equipment for the car wash system and vacuums shall be internal to a fully enclosed building. Vacuum bays shall be covered by a roof structure. Vacuum bays may be self-serve drive-in bays.
6. The entrance and exit to the car wash shall be 200 feet from any residentially zoned property. Provided, however, that the distance restriction may be reduced or waived by the Planning Commission or the Governing Body at the time of preliminary and final development plan approval where the residentially zoned property is not designated on the Future Development Plan Map as being within a residential category. In determining to what degree the 200-foot distance should be reduced, if any, the Planning Commission or Governing Body shall consider the same factors referenced in Section 18.270.050 A1.
7. No amplified speaker used for the kiosk or pay station shall be located within 200 feet of any residentially zoned property. Provided, however, that the distance restriction above may be reduced or waived by the Planning Commission or the Governing Body at the time of

preliminary and final development plan approval where the residentially zoned land is not designated on the Future Development Plan Map as being within a residential category. In determining to what degree the 200-foot distance should be reduced, if any, the Planning Commission or Governing Body shall consider, but not be limited to the factors listed in Section 18.270.050A1, a through d.

**S. Wind turbine(s).**

1. Each application for a special use permit for a wind turbine or wind turbines shall be accompanied by the following information:
  - a. Preliminary development plan (see Section 18.140.190).
  - b. Turbine information, including type, model, size, height, rotor material, rated power output, performance, safety, and noise characteristics of each wind turbine being proposed, tower and electrical transmission equipment.
  - c. Meteorological tower information, if applicable, including location, height, and appearance.
  - d. Digital pictorial representations of "before and after" (photo simulation) views from key viewpoints as may be appropriate.
  - e. The Director, Planning Commission, or Governing Body may require additional technical studies deemed necessary to fully evaluate the application, such as a shadow/flicker model, noise study, geotechnical report, or wildlife impact study.
2. A request for a special use permit for a wind turbine(s) may be approved for an indefinite period of time.
3. **Height** - The maximum height which may be approved for a wind turbine is one hundred fifty (150) feet. Height shall be measured from average grade at the tower base to the highest point of the wind turbine structure, including blades, if applicable. A lightning rod, not to exceed ten (10) feet, shall not be included within the height limitations. The maximum height which may be approved for a roof-mounted wind turbine shall be equal to one-half the height of the building, not to exceed twenty (20) feet. Height shall be measured from the surface of roof on which the turbine is mounted to the highest point of the wind turbine structure, including blades, if applicable.
4. **Minimum lot size** - Ground-mounted wind turbines shall be located on property a minimum of one-half acre in size.
5. **Setbacks** - All wind turbines, other than roof-mounted wind turbines, shall be setback a distance equal to the height of the wind turbine, including blades, if applicable, from all property lines.
6. **Separation requirements** - When two (2) or more ground-mounted wind turbines are located on one lot, they shall be separated by a distance equal to the overall height of one wind turbine system, including blades, if applicable.
7. The Planning Commission or Governing Body shall have the ability to grant a deviation from these standards subject to Section 18.150.070 (H). In support of a deviation request from

these requirements, the applicant shall submit detailed information illustrating the need for the deviation.

8. **Color/Finish** – Wind turbines, including the towers, shall be painted a non-reflective, non-obtrusive color or a color that conforms to the environment and architecture of the community.
9. **Tower design** – All tower structures shall be of self-supporting, monopole construction unless attached to a structurally reinforced roof where such support is not warranted. No lattice structures shall be permitted.
10. **Blade size** – The diameter of the blades for a ground-mounted horizontal-axis, propeller-style wind turbine system shall be limited to one-third the height of the tower.
11. **Lighting** – Wind turbines shall not be artificially lit unless such lighting is required by the Federal Aviation Administration (FAA) or other applicable authority.
12. **Signage** – Signs shall be limited to the appropriate warning signs (e.g. electrical hazard or high voltage) placed on the wind turbine tower(s), electrical equipment, and the wind turbine. Commercial advertising is strictly prohibited.
13. **Federal and State regulations** – All wind turbines shall meet or exceed current State and Federal standards and regulations.
14. **Building code compliance** – All wind turbines shall meet or exceed the current standards expressed in the adopted building codes. A building permit is required prior to the installation of any wind turbine.
15. **Utility connections** – Reasonable efforts shall be made to locate utility connections from the wind turbine(s) underground, depending on appropriate soil conditions, shape, and topography of the site and any requirements of the utility provider. Electrical transformers for utility interconnections may be above ground if required by the utility provider. For electrical transformers with a footprint greater than two (2) square feet in area, landscaping shall be provided where necessary to substantially screen the structure from public view and/or the view of adjacent homeowners. Maintenance of all landscaping shall be the responsibility of the property owner.
16. **Electrical wires** – All electrical wires associated with a wind turbine shall be located underground except for those wires necessary to connect the wind generator to the tower wiring, the tower wiring to the disconnect junction box, and the grounding wires.
17. **Safety shutdown** – Each wind turbine shall be equipped with both manual and automatic overspeed controls to limit the rotational speed of the blade within the design limits of the rotor. Manual electrical and/or overspeed shutdown disconnect switches shall be provided and clearly labeled on the wind turbine structure. No wind turbine shall be permitted that lacks an automatic braking, furling, or feathering system to prevent uncontrolled rotation, overspeeding and excessive pressure on the tower structure, rotor blades, and turbine components.
18. **Minimum blade clearance** – The blade tip clearance for a ground-mounted, horizontal-axis, propeller-style wind turbine shall, at its lowest point, have a ground clearance of not less than thirty (30) feet.

19. **Noise** – The noise emitted from any wind turbine shall not exceed the noise level limits set out in 7.08, except during short-term events such as utility outages and severe windstorms.
  20. **Utility notification** – No building permit for a wind turbine shall be issued until a copy of the utility company's approval for interconnection of a customer-owned generator has been provided. Off-grid systems shall be exempt.
  21. **Removal of abandoned wind turbines** – Any wind turbine that is not operated for energy production for a continuous period of twelve (12) months shall be considered abandoned, and the owner of such wind turbine shall remove the same within ninety (90) days of a receipt of notice from the governing authority notifying the owner of such abandonment. If such wind turbine is not removed within said ninety (90) days, the governing authority may remove such wind turbine at the owner's expense.
  22. **Screening** – Equipment associated with a roof-mounted wind turbine shall be permitted on the roof so long as it is screened from view in accordance with Section 18.450.100. The roof-mounted wind turbine itself shall be exempt from the screening requirement for optimum functionality of the turbine.
- T. Uses previously authorized by conditional use permits issued by Johnson County for properties in the areas annexed by Ordinance No. A-2367 (effective May 8, 2002) or Ordinance No. A-2719 (effective March 13, 2008).**
1. The purpose of this special use category is to provide a means for uses in areas annexed by Ordinance No. A-2367 or Ordinance No. A-2719 that were previously granted a conditional use permit by Johnson County and for which there is no comparable city special use category. Properties that did not previously have a Johnson County conditional use permit cannot utilize this special use category.
  2. Special use permit approval shall not be granted as a matter right, but shall be subject to the same procedures and the same discretionary approval and standards as any other special use permit or any renewal thereof.
  3. The Planning Commission and the Governing Body may approve the special use permit with some or all of the stipulations imposed by the County's conditional use permit. Further, additional or alternative stipulations may be approved, provided such stipulations shall not unreasonably restrict or frustrate the intended use lawfully approved under the conditional use permit.
  4. Applications for this special use category will not be considered when the County approved conditional use permit has been expired for a period of time exceeding 6 months.
  5. Applicants not in compliance with the conditions and stipulations of the County approved conditional use permit may be denied outright.

(History: Ord. ZRR-3044 §2, 2014; ZRR-2968 §2, 2012; ZRR-2836 §15, 2010; ZRR-2795 §8, 2009; ZRR-2684 §2, 2007; ZRR-2491 §3, 2004; ZRR-2420 §21, 2003; ZRR-2285 §18, 2001; ZRR-2180 §2, 99; ZRR-2152 §2, 99; ZRR-2079 §2, 97; ZRR-2004 §10, 96; ZRR-1916 §3, 95; ZRR-1867 §1, 94; ZRR-1858 §1, 94; ZRR-1829 §2, 94; ZRR-1725; ZRR-1637)

### **18.370.050 Revocation of Special Use Permits**

---



**A. Basis for revocation**

Any special use permit granted under the authority of this Chapter is subject to revocation for any or all of the following reasons:

1. Non-compliance with any applicable requirement set forth in Section 18.370.040.
2. Non-compliance with any special conditions imposed at the time of approval of the special use permit.
3. Violation of any provisions of the Code pertaining to the use of the land, construction or uses of buildings or structures or activities conducted on the premises by the permittee or agents of the permittee.
4. Where conditions in the neighborhood have changed to the extent that approval of the permit would be clearly unwarranted if being applied for at the time of revocation.
5. Violation of any other applicable Code provisions or any state or federal law or regulation by the permittee or agents of the permittee, provided that such violations relate to the conduct or activity authorized by the special use permit or the qualifications of the permittee or its agents to engage in such conduct or activity.

**B. Procedure for revocation**

1. The Governing Body may initiate revocation proceedings by a majority vote of the members present and voting at the meeting.
2. Unless the permittee and landowner agree in writing that the permit may be revoked, the Governing Body shall hold a public hearing to consider the revocation of the special use permit.
3. The City shall give the permittee and landowner notice of the scheduled revocation hearing at least five days prior to the date scheduled for such hearing. If the permittee and landowner are present at the meeting of the Governing Body at which the revocation proceedings are initiated, no further notice shall be required; otherwise, notice shall be given by personal service or certified mail, return receipt requested. If the notice cannot be delivered or is not accepted, notice may be given by publishing a notice of hearing in the official City newspaper and by posting a notice of hearing on the property at least five days prior to the date scheduled for the hearing.
4. At the hearing, the City Attorney, or his or her designee, shall present the evidence known to the City which may justify revocation of the special use permit. Testimony may be presented by members of the City staff, Planning Commission or Governing Body, or by such other witnesses as may be called by the City Attorney. Following the presentation of evidence by the City Attorney, any person having relevant evidence may present such evidence to the Governing Body. The permittee, landowner or their attorney may pose questions to any person giving evidence under such conditions as may be imposed by the Mayor or presiding officer. Following the presentation of evidence by the City and any other persons, the permittee and landowner shall be entitled to present evidence or testimony of witnesses. Members of the Governing Body and the City Attorney, or his or her designee, shall be allowed to pose questions to the permittee, landowner and any witnesses called on their behalf. Following the receipt of their evidence, the public hearing shall be closed. After closing the public hearing, the Governing Body may hear closing statements from the City

Attorney, or his or her designee, and the permittee and landowner or their attorney. The Governing Body may render its decision following such closing statements or may take the matter under advisement.

5. No special use permit shall be revoked unless a majority of the Governing Body is satisfied by a preponderance of the evidence that grounds for revocation exist. Any motion for the revocation of a special use permit shall clearly state the grounds for revocation. In addition, where the basis for revocation is "changed conditions" pursuant to subsection A.4. of this Section, revocation may only occur upon an explicit finding that revocation is necessary for the protection of the public health, safety and welfare. Adoption of any motion to revoke a special use permit may be made subject to subsequent adoption of written findings of fact and conclusions of law, at the discretion of the Governing Body.
6. An appeal of any decision of the Governing Body to revoke a special use permit may be filed in the District Court of Johnson County, Kansas, pursuant to K.S.A. 12-760, or amendments thereto. Any appeal taken shall not suspend the order of revocation during the pendency of the appeal unless so ordered by the District Court.

(History: Ord. ZRR-2795 §9, 2009; ZRR-2454 §11, 2003; ZRR-1725; ZRR-1637)

***Where other dog daycare, boarding and grooming facilities are located in overland park, ks in commercial districts.***

Puppy's Play Pen  
5205 W. 95th St.  
O.P. KS

Google Maps Overland Park, Kansas

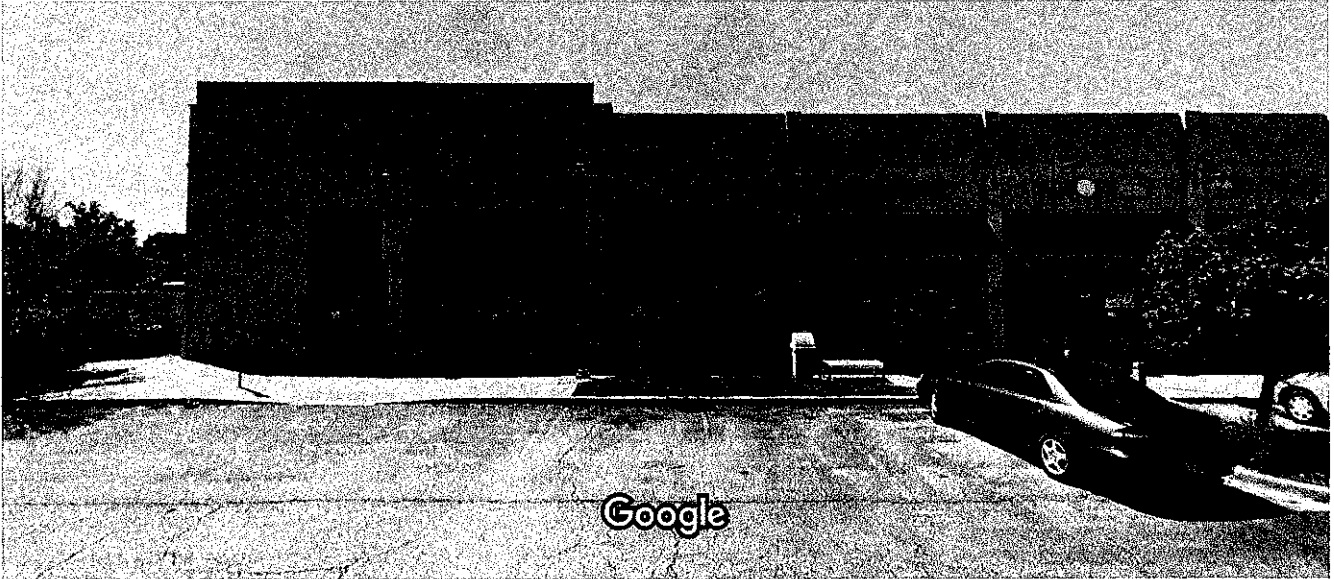
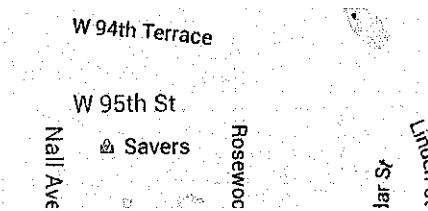

Image capture: May 2015 © 2016 Google

Street View - May 2015



Zoning - Commercial - 1  
w/ special use permit

Surrounding Businesses

- Sun Rice - Restaurant
- Domino's Pizza
- State Farm Insurance
- Conroy's Public House - Bar
- Trailwood Elementary School

Other -  
Residential

Google Maps Rosewood

Puppy's Playpen  
5205 W. 95th St.  
O.P. KS



Image capture: May 2015 © 2016 Google

Overland Park, Kansas  
Street View - May 2015

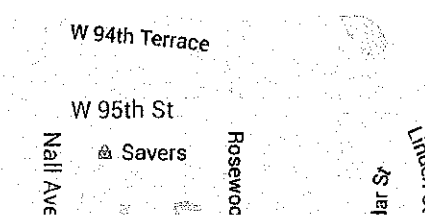

outside  
play yard

# Kennel Creek

10750 El Monte St.

Google Maps El Monte St OP, KS



Image capture: Aug 2014 © 2016 Google

Overland Park, Kansas

Street View - Aug 2014



Zoning -

Commercial - 2

w/ special use

## Surrounding Businesses

- Americas Best Value Inn + Suites
- McCray Lumber
- Al Huber General Contractor
- Heartland Fencing Academy

## Other Amenities

- Indian Creek Bike Trail

Two Dogs and a Cat  
7801 W. 119th Street.

Google Maps W 119th St O. P. , KS

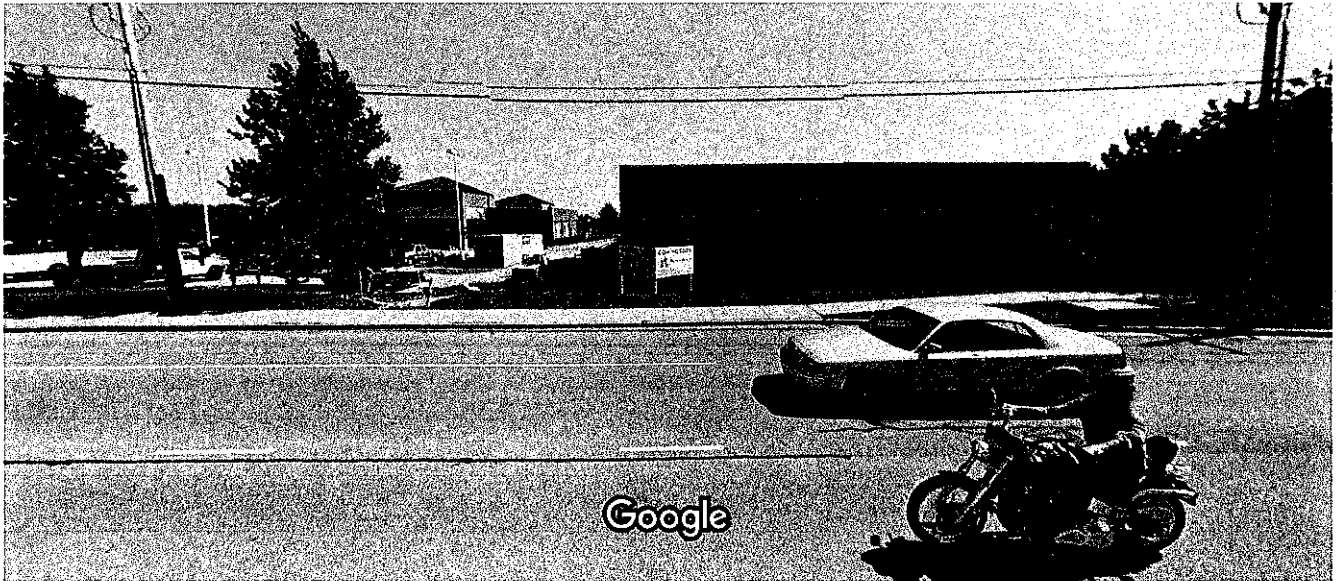
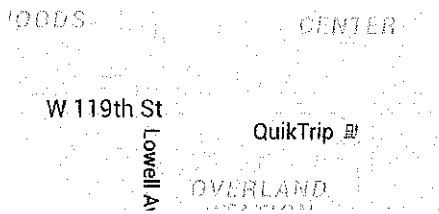

Image capture: Aug 2015 © 2016 Google

Overland Park, Kansas

Street View - Aug 2015



Zoned - Commercial-2  
w/ Special use

### Surrounding Businesses

- Holy Cross Lutheran Church
- H+R Block
- Firehouse Subs
- Beauty Brands

Pawz at Play  
- Cage-less Facility

Google Maps

Mastin St

11200 Mastin St.  
O.P. KS



Image capture: Sep 2011 © 2016 Google

Overland Park, Kansas

Street View - Sep 2011

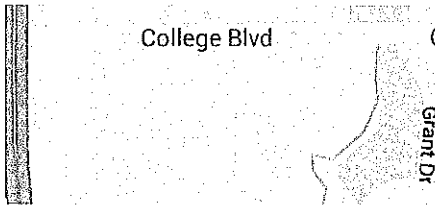

Zoning - Commercial - 2  
w/ Special use

Surrounding Businesses

- Capitol Federal
- Bowling Alley - AMF College lanes
- Car X



***Sound Studies done by Camp Bow Wow***

***2007***

***Pulled for Overland Park, KS***

***Website***

***[www.OPkansas.org](http://www.OPkansas.org)***



North side of the brick building that would be exposed to the site.

On the East side of the building, there will be one 3' x 6'8" metal fire door as well as two 6' x 6'8" double metal fire doors. The neighbor to the East has drive-in dock doors and fire exit doors on the West side of the brick building that would be exposed to the site.

On the North side of the building, there are four 89 1/2" x 27 1/2" windows, one glass door and one drive-in door. The drive-in door is sufficiently insulated to prevent sound emission; however, weather sealing is required where the door meets the building and this will be added. Two of the windows are located in a suite room and in a utility room. The glass side door and one window are in the kennel area. The neighbor to the North has three small windows on the South side of the cement building that would be exposed to the site.

Interior baffling would not be helpful in reducing emissions due to the solid nature of the brick building.

### **Sound Studies at Comparable Dog Day Care and Boarding Sites**

We studied the sound issue at existing facilities in Overland Park, using both objective and subjective methods.

**Pawz at Play – College and Mastin:** We interviewed staff at Capitol Federal Savings, a neighbor to the North, and Car-X, a neighbor to the South. Staff at both sites said that they heard barking but had no complaints about the barking interfering with their ability to operate effectively





**Capitol Federal ATM next to Pawz at Play (fence for Pawz at Play approximately 20 to 30 feet from ATM):**

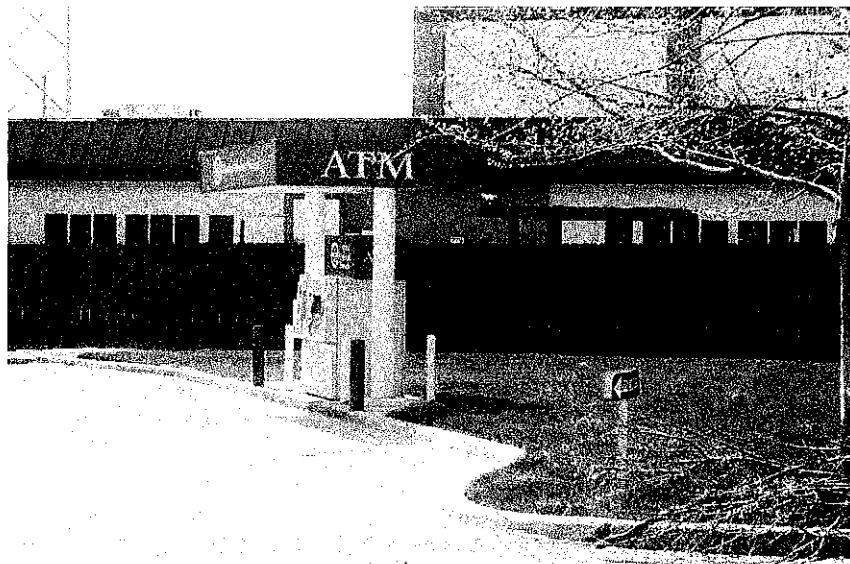

**Puppy's Playpen – 95<sup>th</sup> and Nall:** This facility is on the end of a strip center, and we interviewed the neighbors, and again, there was no complaint about the sound level at this facility.





## Decibel Sound Study

The following chart shows different readings taken at local sites as well as benchmark readings for comparison purposes. It should be emphasized that people who are inside a neighboring office building would have exposure similar to that as described in the measurements taken when the dogs were inside (52 dBA). It should also be noted that dog barking has a tonal quality that is more noticeable than other types of mechanical sound, so psychologically, the human ear might be as sensitive to barking that is actually 10dBA less than a mechanical sound. We are confident that the sound levels from activity at Camp Bow Wow will be no more intrusive than other activities in the Congleton Industrial Park, including the heavier traffic on Nieman Road.

### Comparative Sound Energy Measurements

Change of 3 dBA is barely noticeable;  
change of 5 is noticeable; change of  
10 is double

Date	Location	Noise Source	dBA Measurement	Subjective Measurement
		Threshold of pain	130	-
		Jet engines	120	DEAFENING
		Loud rock band	110	-
		Loud horn	100	-
		8-hour industrial noise exposure limit	90	VERY LOUD
9/19/2006	Camp Bow Wow Troy, MI	20 feet away from dogs who had been incited to bark	82	-
		Busy downtown street	80	-
3/10/2007	350 feet from Highway 69-East side of Nieman	Light highway traffic	80	-
3/10/2007	9120 Nieman	Busy street traffic - 8:30 a.m.	76	-
		Stenographic room	70	LOUD
3/10/2007	9120 Nieman	Medium traffic levels	64	-
		100 feet away from freeway	60	-
9/19/2006	Camp Bow Wow Troy, MI	100 feet away from dogs who had been incited to bark	59	-
		Average open office	60	MODERATE
		Soft background music	40	-
		Average residence - No activity	30	QUIET
		Whisper	20	-
		Human breathing	10	VERY QUIET
		Threshold of audibility	0	-