

**NOTE:**

1. City of Lee's Summit UDO and Design & Construction Manual requirements shall govern over other specifications.
2. Contractor shall flag all utilities above and below surface, prior to commencement of removal operations.
3. Contractor shall lawfully dispose of removed items in accordance with all applicable local, state, federal and other applicable guidelines.
4. Contractor shall grade the site to drain during demolition operations. Standing water, or ponding shall not be allowed.
5. Existing trees to remain in place shall be protected from damage during construction operations. Reference tree protection detail on this sheet.
6. Contractor shall bench excavations as necessary to accommodate demolition and removal operations of structures and foundations. Benches shall not exceed 5 feet in height. Maximum slope for benched excavations shall not exceed a ratio of 1.5 feet horizontal to 1.0 foot vertical.
7. Contractor shall coordinate removal of utilities with the appropriate utility company/contact. All utilities shall be removed to the property line and properly capped.
8. Backfill of trenches/voids for utility line, storm and sanitary sewer pipes and related structure removals at the end of each day. Backfill shall be placed in 8" loose lifts and compacted to 95% of maximum dry density as per ASTM D 698, standard proctor. Excavated trenching remaining open shall not exceed 25 linear feet. The contractor shall place a temporary construction fence around any excavation or structures remaining open.
9. Contractor shall place a temporary construction fence around the open excavations of the removed structures until the void has been backfilled to the proposed finished grade.
10. Pavements and other infrastructure not identified for removal and damaged by Contractor's operations shall be repaired and/or replaced by Contractor's at no cost to Owner.

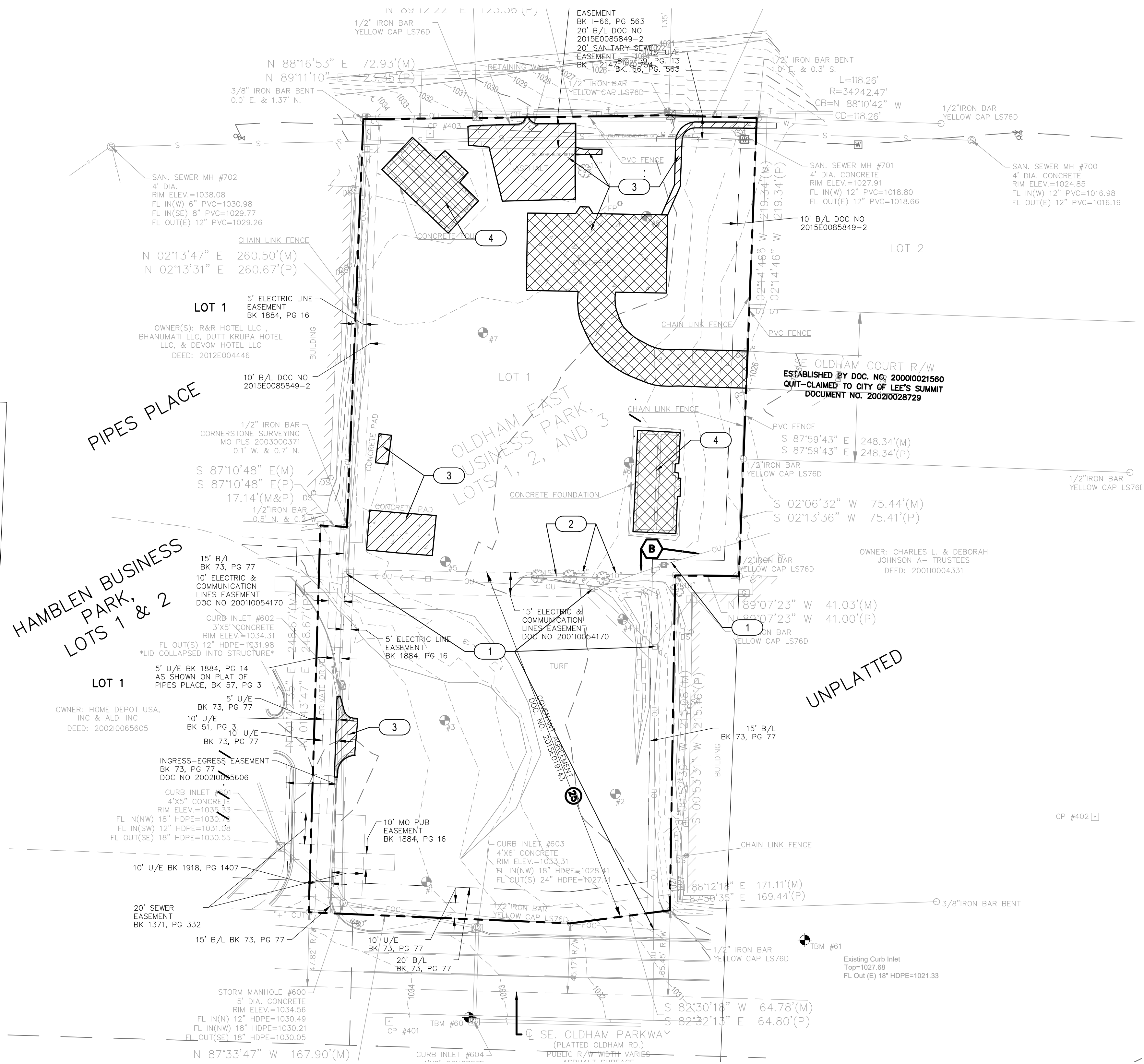

mo1call.com 1-800-DIG-RITE  
1-800-344-7483  
**Missouri811**  
know what's below  
Call before you dig.  
Dial: 811

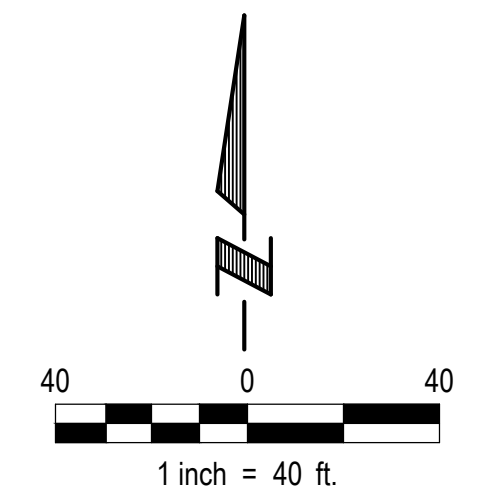

**LEGEND**

	Remove Existing Building/Structure/Foundation
	Remove Existing Paving
	Sawcut Full Depth (Removal Limit/Pipe Removal)
	Property Line

**REMOVAL NOTES**

NO	REMOVAL NOTES
1	Contractor to coordinate removal and relocation of existing overhead power with Power Utility.
2	Remove Existing Trees
3	Remove Existing Pavement (All pavement removals shall be saw cut full depth prior to removal).
4	Remove all footings and foundations from existing building footprint. Cap all utilities at property line and remove from that point to service connection.* *Includes removing all sanitary sewer service lines and utility meters. All existing fencing on the subject property shall be removed. If it appears that a neighbor is using the fence, Contractor shall contact them and give them opportunity to salvage. Owner and Contractor shall coordinate with Electrical Utility regarding removal and relocation of Electrical Service Line Crossing Property, as well as coordinating relocation and removal of easement.

**EXTRA SPACE STORAGE - LEE'S SUMMIT**  
 650 OLDHAM PARKWAY  
 LEE'S SUMMIT, MO

**REMOVAL PLAN**  
SCALE AS NOTED



**E & A CONSULTING GROUP, INC.**  
 Engineering • Planning • Environmental & Field Services  
 10909 Mill Valley Road, Suite 100 • Omaha, NE 68154  
 Phone: 402.895.4700 • Fax: 402.895.3599  
 www.eacg.com  
 Missouri State Certificate of Authority # E-2014008210

E&A Job # :  
2018.037.006

**Hernly ASSOCIATES**

1100 Rhode Island  
Lawrence, Kansas  
66044  
785 - 749 - 5806  
FAX 785 - 749 - 1515

DRAWINGS

Date: 9/18/2018  
Drawn by: DRH  
Checked by: DRH  
Revisions:

**C1**

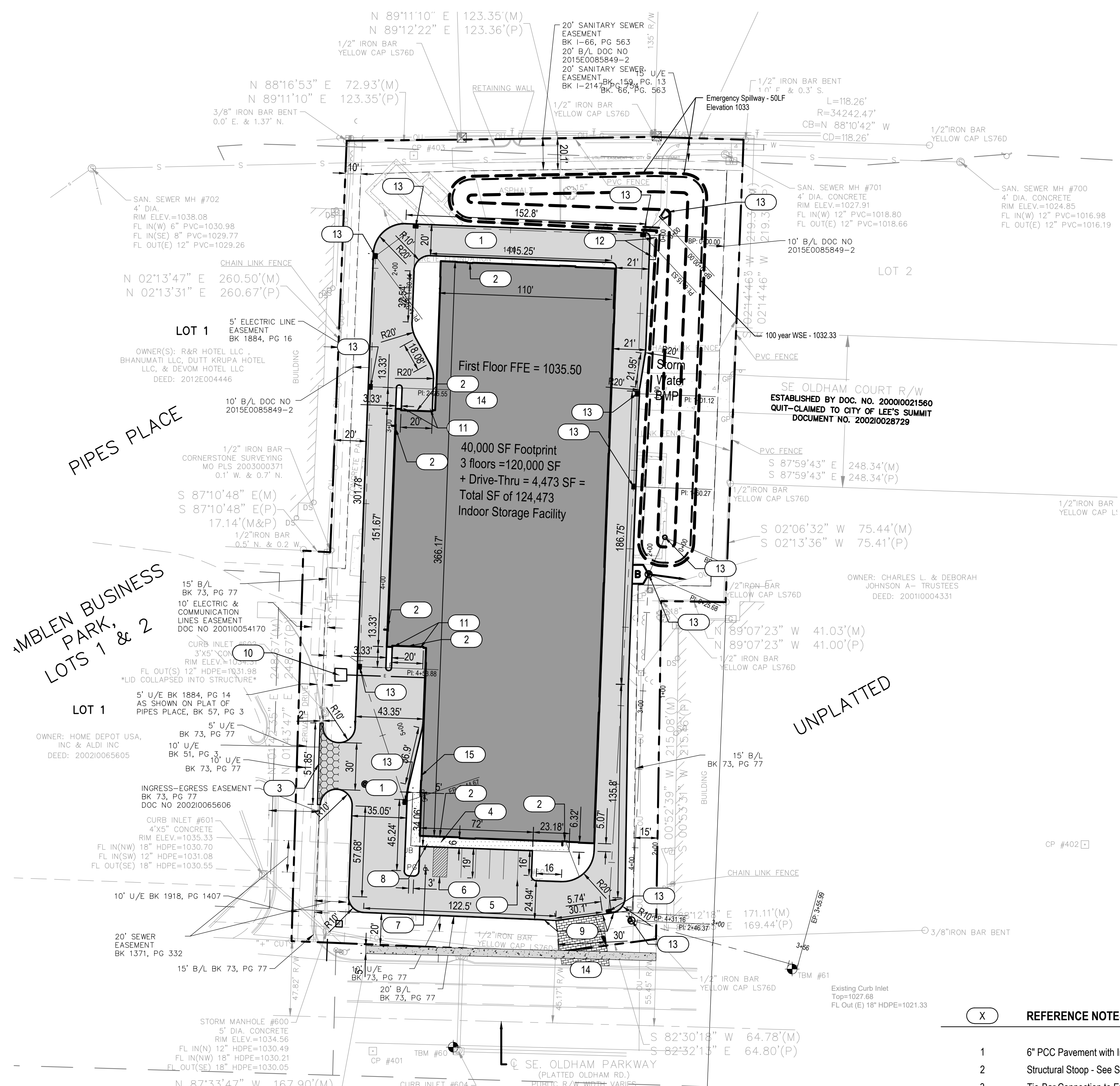
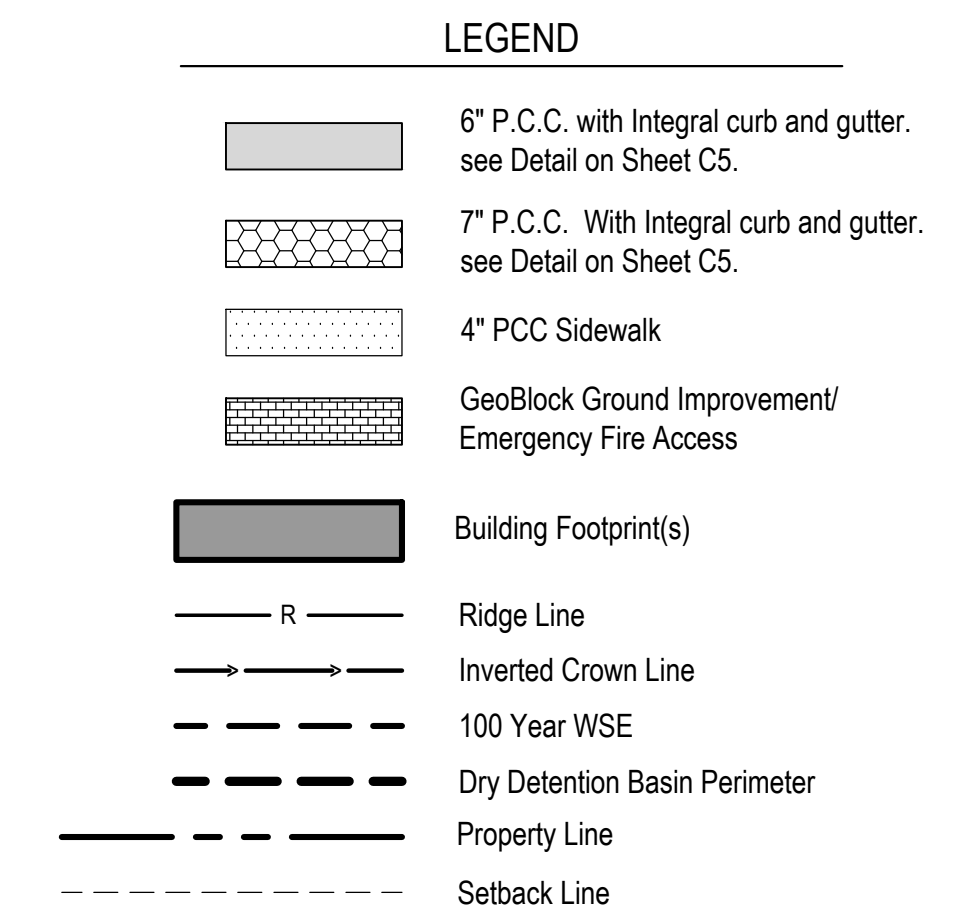
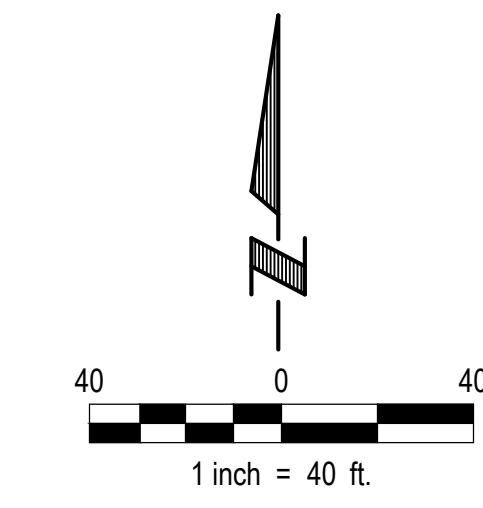

**GENERAL PAVING AND LAYOUT NOTES**

1. All back of curb and sidewalk radii are 3' unless indicated otherwise.
2. All parking stalls are 9' wide.

**Land Use Table & Parking Information**

City of Lee's Summit, Missouri Municipal Code  
Mini-warehouse parking requirements are 2 for facility, and 1 for each employee on maximum shift.  
Max Shift = 2 Employees  
Total Parking Required = 4  
Regular Parking Stalls = 5  
HC Parking Stalls = 1  
Total Parking Provided = 7

Floor Area Ratio (FAR) = 0.991  
Impervious Coverage = 58.1%

**REFERENCE NOTES**

- 1 6" PCC Pavement with Integral Curb - See Detail on Sheet C5
- 2 Structural Sloop - See Structural & Architectural Plans
- 3 Tie-Bar Connection to Existing Pavement - See Detail on Sheet C5
- 4 Handicap Ramp - See Detail on Sheet C5
- 5 Painted Parking Striping, 4" Wide, See Detail on Sheet C5
- 6 Painted Parking Striping, 4" Wide @ 45° with 4" Wide Perimeter Stripe, See Detail on Sheet C5
- 7 Painted Handicapped Symbol - See Detail on Sheet C5
- 8 Van Accessible Handicap Sign and Post - See Detail on Sheet C5 (May be building mounted)
- 9 Transition Curb from Full Height Curb to Type CG-2 over 10 LF for Fire Access Drive ONLY. 30' Width of Fire Access Drive shall be CG-2 mountable curb. All other Curb and Gutter shall be Type CG-1.
- 10 Transformer Location - See Electrical Plans
- 11 Bollards at Overhead Doors - See Detail on Sheet C5
- 12 Trash Enclosure, See Sheet C7 & Architectural Plans for Details
- 13 Storm Sewer Structure
- 14 30' Wide Geoweb Ground improvement for Emergency Fire Access, See Sheet C11 for Details.
- 15 Building mounted Knox box. Coordinate with Architectural Plans.

**CONSTRUCTION NOTES - 650 SE Oldham Parkway**

1. City of Lee's Summit UDO and Design & Construction Manual requirements shall govern over other specifications.
2. Site is 2.884 Acres, Zoned CS.
3. Impervious Area is 78,090 SF = 1.793 Acres.
4. No sidewalk along along the west property line frontage; 5' sidewalk along Oldham Parkway frontage.
5. Pavement subgrade shall be prepared and compacted in accordance with City of Lee's Summit for Public Works Construction, Latest Edition.
6. All integral curbs shall be Straight Back Curb & Gutter (Type CG-1) per APWA-Kansas City Metropolitan Chapter Standard Drawing Number C-1.
7. Water-reducing admixture shall be added to all hand-placed and finished concrete.
8. Paving widths shall be as shown on plans. All dimensions shown are edge of pavement to edge of pavement.
9. A diamond edge saw blade shall be used for cutting all required contraction and longitudinal pavement joints.
10. THE CONTRACTOR shall construct ADA compliant curb ramps at all intersection returns where new sidewalk is constructed, as well as where existing sidewalk has been removed. All ADA compliant curb ramps shall conform to the American Public Works Association Kansas City Metropolitan Chapter Drawing SW-1 and any additions or revisions thereto. Truncated Domes shall be selected from the list of approved products and shall be "RED BRICK" in color. The aforementioned publication can be found at <http://kcmetro.apwa.net/content/chapters/kcmetro.apwa.net/file/Specifications/APWAStdDwgs.pdf>
11. Within one (1) hour the concrete pavement shall be cured using a white pigmented liquid membrane-forming curing compound that has been approved by the City of Lee's Summit. Apply liquid membrane-forming curing compound at the concentration and application rate recommended by the manufacturer.
12. Subgrade Preparation includes the adjustment of the subgrade under all areas to be surfaced including driveways, intersections, and the area 48 inches beyond the longitudinal edges of the pavement or the backs of curbs for proper placing of the pavement slab. The Contractor shall scarify and recompact the subgrade to a depth of one foot. The top 12" of subgrade as described shall be compacted as outlined in the City of Lee's Summit Design & Construction Manual.
13. Mechanical units shall be totally screened from view in accordance with UDO Article 7.
14. Contractor to locate and relocate any existing utilities that may conflict with construction as needed.
15. The development shall meet requirements of the Unified Development Ordinance, Design and Construction Manual, Access Management Code and other ordinances for development.
16. Every ADA Accessible parking space shall be identified by a sign, pole mounted or on another structure, between 36 and 60 inches above the ground as measured from the bottom of the sign and the head of the parking stall.
17. All identifying signs shall conform with the Detail on Sheet C5, as well as the MUTCD.
18. All Landscaping must meet Article 14 of the UDO.
19. Two-way traffic movement is provided.
20. See Architectural Plans for building dimensions, monument signs and all lighting details.
21. Parking spaces shall be 9' by 19' for perimeter stalls with curb and interior stalls with curb at front.
22. Watershed is East Fork-Little Blue River, to Prairie Lee Lake.
23. Knox Padlocks shall be provided on all gates, per IFC 506.1. The Key Box shall be an approved type in accordance with UL 1037, and shall contain keys to gain access as required by the fire code official. See Sheet C11, Fire Plan.



**E & A CONSULTING GROUP, INC.**  
Engineering • Planning • Environmental & Field Services

10909 Mill Valley Road, Suite 100 • Omaha, NE 68154  
Phone: 402.895.4700 • Fax: 402.895.3599  
www.eacg.com

E&A Job #: 2018.037.006  
Missouri State Certificate of Authority # E-2014008210

EXTRA SPACE STORAGE - LEE'S SUMMIT  
650 OLDHAM PARKWAY  
LEE'S SUMMIT, MO

**Hernly ASSOCIATES**

1100 Rhode Island  
Lawrence, Kansas  
66044  
785 - 749 - 5806  
FAX 785 - 749 - 1515

DRAWINGS

Date: 9/18/2018  
Drawn by: DRH  
Checked by: DRH  
Revisions:

**GENERAL GRADING NOTES**

- City of Lee's Summit UDO and Design & Construction Manual requirements shall govern over other specifications.
- The General Contractor and/or sub-contractor shall have complete responsibility for damage caused by blowing dust from his construction activities.
- Topsoil and non-woody vegetation shall be stripped to a depth of 6" in areas to be graded.
- Topsoil generated from stripping operations shall be stockpiled in an approved location and re-spread on areas finish graded to receive topsoil.
- Rubble and waste materials from site clearing and demolition shall be removed from the site and lawfully disposed, salvaged, or recycled. Where fence posts are removed, their concrete bases shall be excavated and completely removed. Waste materials shall not be buried on site.
- OSHA's Construction Standards for Excavations require that the Contractor's excavation activities follow certain worker safety procedures. Excavations over 4 feet deep shall be sloped back, shored, or shielded. The maximum allowable slope for an unbraced excavation in these soils is 1H:1V and 1.5H:1V respectively, although other provisions and restrictions apply. The Contractor is solely responsible for site/excavation safety and compliance with OSHA regulations.
- Existing fill soils within proposed building footprints including a 5 foot offset of the proposed building footprint shall be excavated a minimum depth of 18 inches, backfilled and compacted as structural fill.
- All structural fill and backfill soils shall be low plasticity, cohesive soil that are free of organic material or debris. Structural fill/backfill materials shall have a Liquid Limit less than 45 and a Plasticity Index less than 20. Excavated site soils will generally be suitable for use as structural fill.
- Fill Compaction Requirements:**  
 Shallow Foundations -  
 Areas to receive fill shall be scarified to a minimum depth of 6". Fill shall be placed in lifts not to exceed 8" in loose thickness. Structural Fill shall be compacted to a minimum of 95% of the maximum dry density // ASTM D-698 (Standard Proctor) // ASTM D1557 (Modified Proctor) // at a moisture content between -1 and +3% of optimum. // The Geotechnical Engineer shall observe and test bearing soils exposed in all foundation excavations. //  
 All Other Locations  
 Areas to receive fill shall be scarified to a minimum depth of 6". Fill shall be placed in lifts not to exceed 8" in loose thickness. Structural Fill shall be compacted to a minimum of 95% of the maximum dry density // (ASTM D-698, Standard Proctor) // ASTM D1557 (Modified Proctor) // at a moisture content between -1 and +3% of optimum. All requirements to meet or exceed City of Lee's Summit requirements.
- PCC Pavements: Prepare subgrade as per notes and specifications identified on the Site Layout and Paving Plan Sheet and the requirements of the Geotechnical Report, to meet or exceed City of Lee's Summit requirements.
- PCC Sidewalks: Prepare subgrade as per notes and specifications identified on the Site Layout and Paving Plan Sheet and the requirements of the Geotechnical Report to meet or exceed City of Lee's Summit requirements.
- Backfill soils in utility trenches shall be compacted to a minimum of 95% of the maximum dry density as per ASTM D698 (Standard Proctor) at a moisture content between -1% and +3% of optimum. Fill shall be placed in loose lifts appropriate to the equipment and methods used for compaction. Granular backfill shall not be used in exterior trenches. A "trench plug" shall be constructed to a distance 5 feet from face of building exteriors. The plug material shall consist of a clay compacted at a water content at or above the soil's optimum water content. The clay fill should be placed to completely surround the utility line and compacted as described above.
- Imported fill material, if required, shall be free of organic matter and debris, and shall be a clean, inorganic silt or lean clay with a Liquid Limit less than 45 and a Plasticity Index less than 20. Imported material shall not contain any foreign material or debris with a dimension greater than 3".
- Any excess material shall be disposed of at an off-site at a location determined by the Contractor.
- Unless otherwise noted, all spot elevations shown are Top of Curb (TC), Top of Slab (P) or Finished Grade (G).
- The subgrade of the floor slab shall be reworked and compacted as structural fill prior to concrete placement. The upper 12 to 18 inches of base soils shall be compacted to a minimum of 95% of the maximum dry density as per ASTM D698 (Standard Proctor) at a moisture content between -2% and +3% of optimum. 4 inches of free draining granular material shall be placed as an aggregate base on top of the structural fill. Floor slab shall be rough graded and proof rolled prior to fine grading and placing aggregate base.
- If unstable soils are encountered in the bottom of shallow foundations or subgrade areas, the Contractor shall implement over-excavation and backfill practices with a more suitable material. The Contractor shall contact the Geotechnical Engineer to identify limits and depths of over-excavation.
- Exposed project site soils shall be stabilized as shown in the Storm Water Pollution Prevention Plan and Landscaping Plan.
- The Recommendations of the Geotechnical Report shall control in all instances where subgrade preparation, backfill and compaction are concerned to meet or exceed City of Lee's Summit requirements.

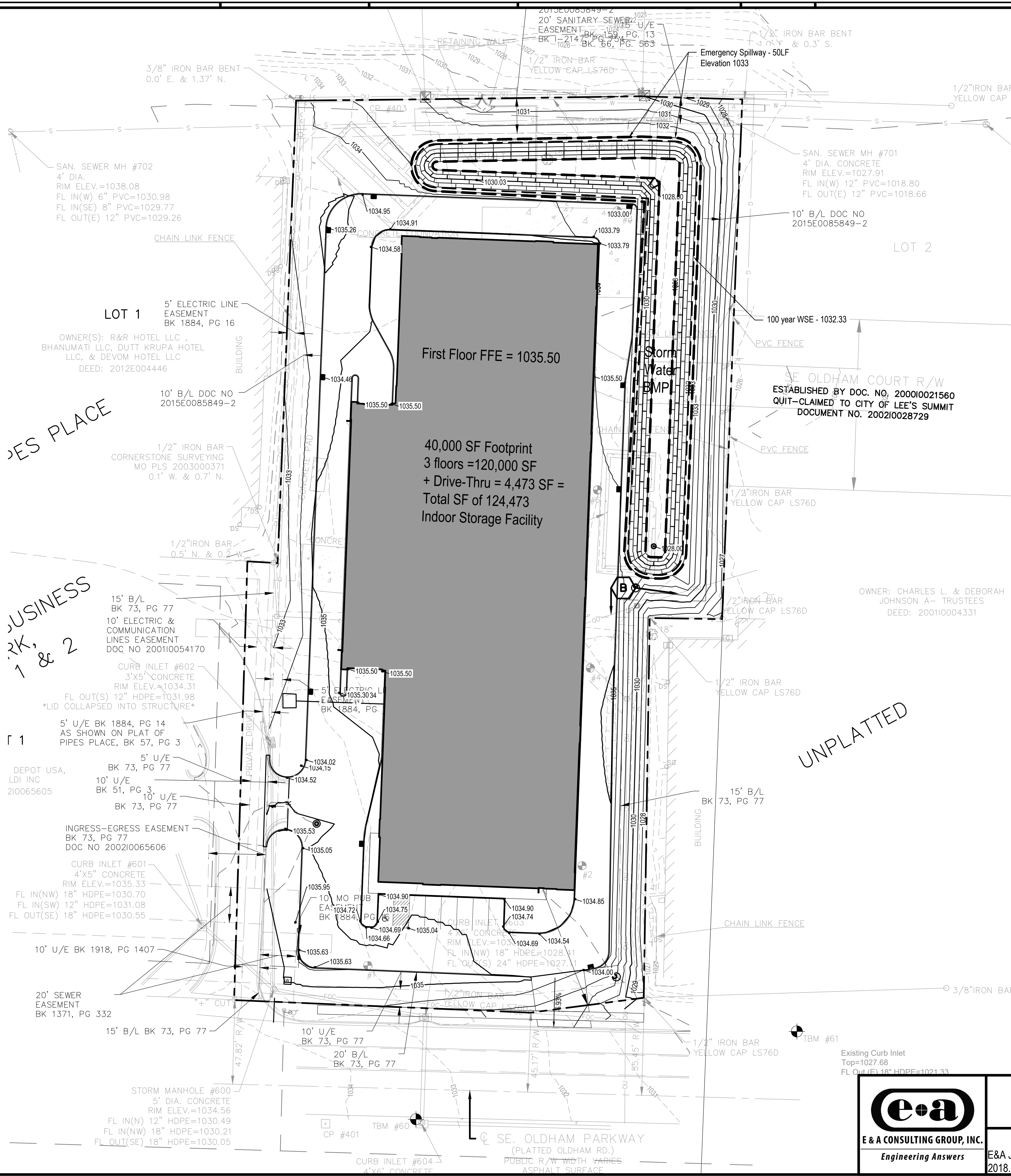

mo1call.com 1-800-DIG-RITE  
 1-800-344-7483  
**Missouri811**  
 know what's below.  
 Call before you dig.  
 Dial: 811

STATE OF MISSOURI  
 David R. Harnisch, Jr.  
 Civil Engineer  
 MCH PE-2015003013

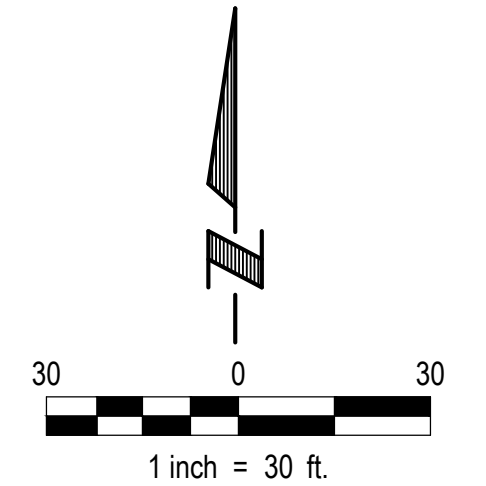

**LEGEND**

	Ridge Line
	Inverted Crown Line
	Existing Contours
	Proposed Contours
	Proposed Spot Elevation Top of slab/Finished Grade
	GeoBlock Ground Improvement/ Emergency Fire Access
	Building Footprint(s)
	100 Year WSE
	Dry Detention Basin Perimeter
	Property Line
	Setback Line

**EXTRA SPACE STORAGE - LEE'S SUMMIT**  
 650 OLDHAM PARKWAY  
 LEE'S SUMMIT, MO

**Hernly ASSOCIATES**  
 1100 Rhode Island  
 Lawrence, Kansas 66044  
 785-749-5806  
 FAX 785-749-1515

**DRAWINGS**  
 Date: 9/18/2018  
 Drawn by: DRH  
 Checked by: DRH  
 Revisions:

**e+a**  
**E & A CONSULTING GROUP, INC.**  
 Engineering Answers

**E & A CONSULTING GROUP, INC.**  
 Engineering • Planning • Environmental & Field Services  
 10909 Mill Valley Road, Suite 100 • Omaha, NE 68154  
 Phone: 402.895.4700 • Fax: 402.895.3599  
 www.eagc.com  
 Missouri State Certificate of Authority # E-2014008210

E&A Job # :  
 2018.037.006

**GRADING PLAN**  
 SCALE AS NOTED

**C3**

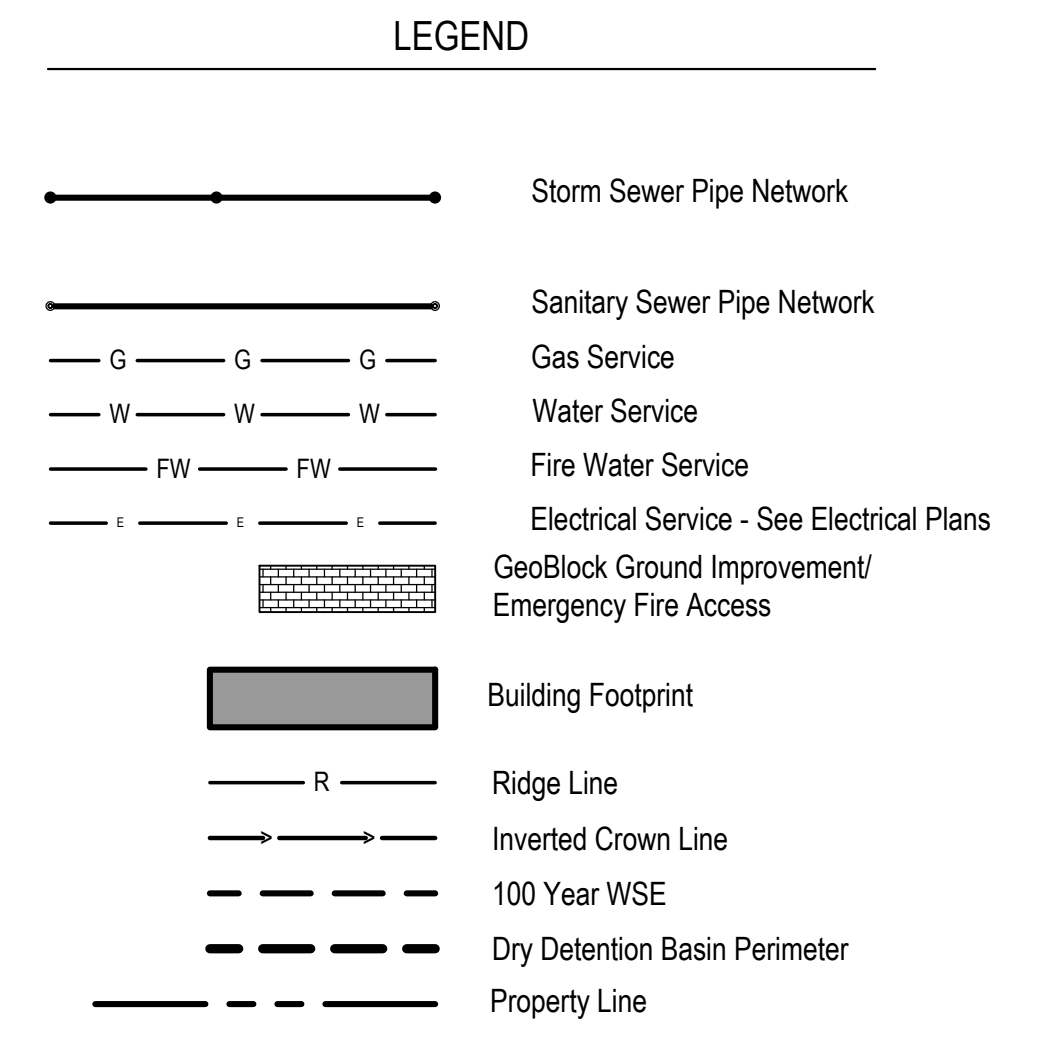
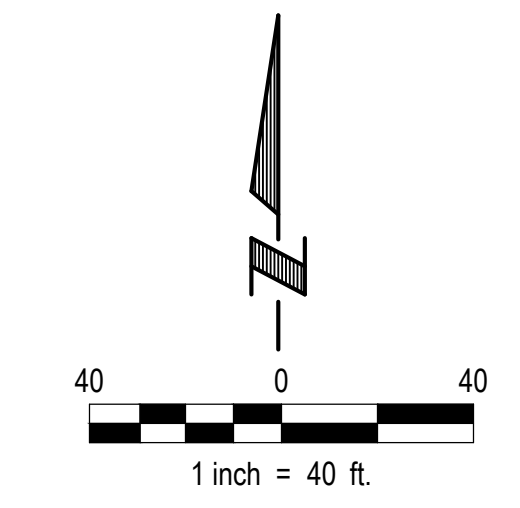

**W WATER REFERENCE NOTES**

- W1 Tap Existing Water Main with Service Connection and Meter Well. Coordinate Tap with Local Utility.
- W2 Construct Water Service Line in Accordance with Local Utility Specifications.
- W3 See Mechanical/ Plumbing Plans for Continuation and line size.

**SS SANITARY REFERENCE NOTES**

- SS1 See Mechanical Plans for continuation of 6" Sanitary Service Line. Minimum slope of sanitary sewer lines shall be 1%

**S STORM REFERENCE NOTES**

- S1 Flared End Section, see Detail Sheet C9 for outlet erosion protection detail.
- S2 Connection from internal roof drain - see Mechanical Plans for continuation.

**P POWER REFERENCE NOTES**

- P1 Approximate Transformer Location. Shown for reference only. Refer to Electrical Plans for transformer pad dimensions and details.
- P2 Approximate Power Service Line Location. Shown for reference only. Refer to Electrical Plans for service horizontal and vertical alignment.
- P3 Refer to Electrical Plans for Primary Service Connection Details.

**CONSTRUCT STORM SEWER STRUCTURE**

NO.	DESCRIPTION
FES 1	24" Flared End Section, Rim = 1031.50 FL (18" In) = 1028.00
GI1	2' x 3' Grate Top Inlets, Rim = 1035.16 FL (24" Out) = 1031.24
GI2	2' x 3' Grate Top Inlets, Rim = 1034.71 FL (24" In) = 1030.79 FL (18" Out) = 1030.79
GI3	2' x 3' Grate Top Inlets, Rim = 1034.46 FL (18" In) = 1029.90 FL (18" Out) = 1029.90
GI4	City of Omaha Grate Top Inlets, Rim = 1035.22 FL (18" Out) = 1029.48 FL (18" In) = 1029.48
GI5	City of Omaha Grate Top Inlets, Rim = 1034.94 FL (18" In) = 1029.24 FL (18" Out) = 1029.24
GI6	City of Omaha Grate Top Inlets, Rim = 1033.05 FL (18" In) = 1028.16 FL (18" Out) = 1028.16 FL (24" In) = 1028.16
GI7	2' x 3' Grate Top Inlets, Rim = 1033.45 FL (24" In) = 1028.66 FL (24" Out) = 1028.66
GI8	2' x 3' Grate Top Inlets, Rim = 1034.01 FL (24" In) = 1028.96 FL (24" Out) = 1028.96
GI9	2' x 3' Grate Top Inlets, Rim = 1034.23 FL (24" Out) = 1030.31
MH1	Lee's Summit Storm Sewer MH - 54" I.D., Rim = 1032.00 FL (18" Out) = 1023.10 FL (15" In) = 1023.10
MH3	Lee's Summit Storm Sewer MH - 54" I.D., Rim = 1032.93 FL (15" Out) = 1026.74 FL (15" In) = 1026.74
RS1	12" Diameter Nyloplast Riser Structure, Rim = 1028.94 FL (15" Out) = 1027.00
TIS	Existing Curb Inlet, Rim = 1023.13 FL (18" In) = 1021.33

**CONSTRUCT SANITARY SEWER PIPE**

ID	Dia	Length	Slope	Remarks
S1	4"	397.38	1.41%	
S2	4"	35.58	1.00%	

**CONSTRUCT STORM SEWER PIPE**

ID	START STRUCTURE	END STRUCTURE	Dia.	Length	Slope	Remarks
1	GI1	GI2	24"	90.78	0.50%	
2	GI2	GI3	18"	178.34	0.50%	
3	GI3	GI4	18"	83.33	0.50%	
4	GI4	GI5	18"	31.78	0.75%	
5	GI5	GI6	18"	144.91	0.75%	
6	FES 1	GI6	18"	15.53	1.00%	
7	GI7	GI8	24"	101.12	0.50%	
8	GI8	GI7	24"	59.15	0.50%	
9	GI9	GI8	24"	270.89	0.50%	
10	MH3	RS1	15"	25.68	1.00%	
11	MH1	MH3	15"	220.69	1.65%	
12	TIS	MH1	18"	109.62	1.61%	

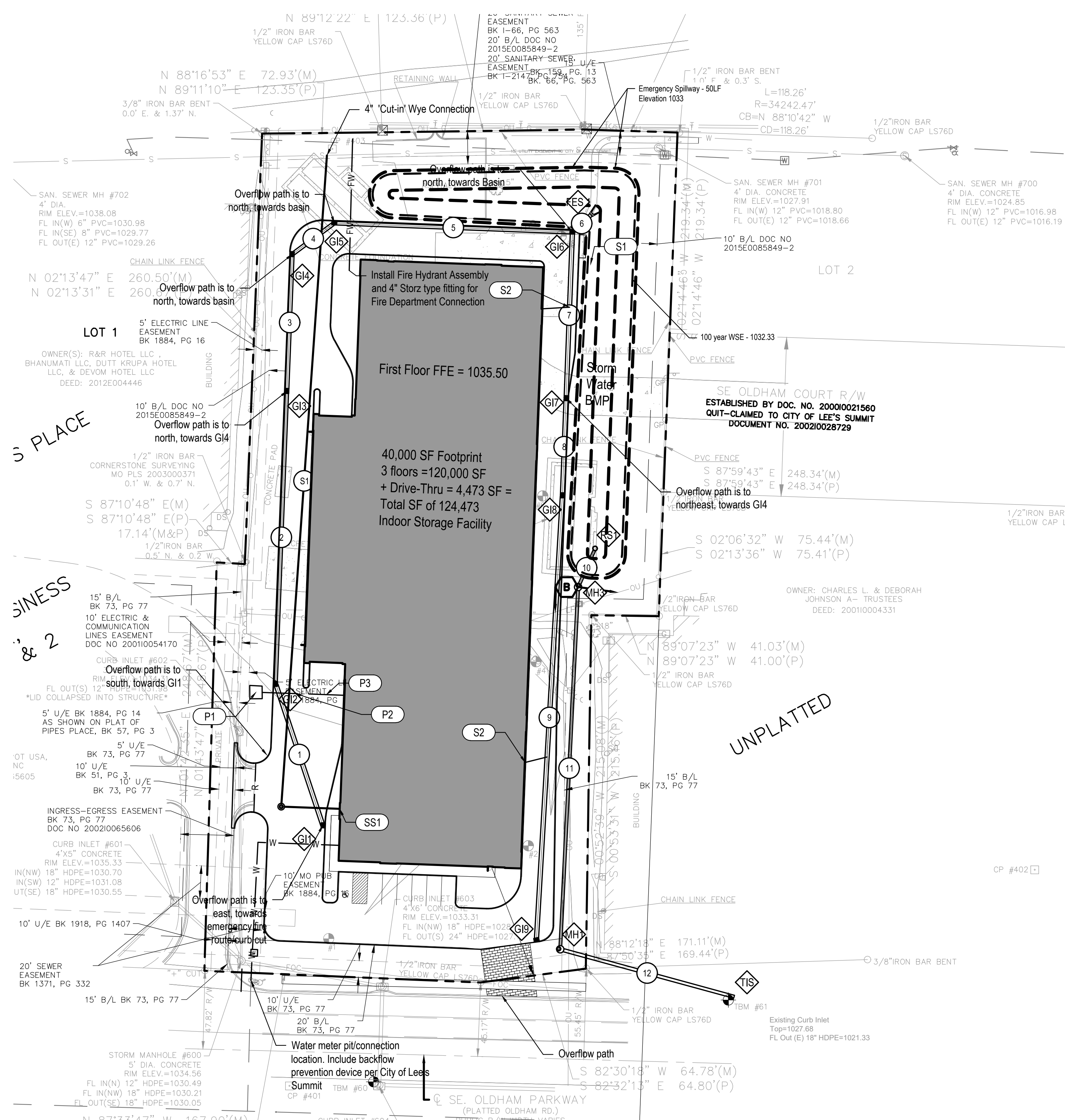

- General Notes**
- City of Lee's Summit UDO and Design & Construction Manual requirements shall govern over other specifications.
  - All utility installation shall be in accordance with Lee's Summit DESIGN AND CONSTRUCTION MANUAL PER Ordinance 5813. See Manual for specifications and standard details.
  - Water service to be Type 'K' copper line, see Mechanical Plans for line size.
  - Sanitary sewer service to be 6" Schedule 40 or DR-26 PVC at 1% Minimum Slope.
  - Trench checks are to be provided on all service laterals within 5' of the sanitary sewer line.
  - Contractor to Contact the Water Utilities Department, Operations Division at 816.969.7606 to schedule water main taps and cut-ins, 48 hours in advance.
  - Contractor to coordinate electrical service with KPC&L.

- PROJECT UTILITY CONTACTS**
- City of Lee's Summit Department of Public Works, 220 SE Green Street, Lee's Summit, MO. 816-969-1800.
  - KCPL, 130 SE Hamblen Road, Lee's Summit, MO. 816-347-4320.
  - Missouri Gas Energy, 3025 SE Clover Road, Lee's Summit, MO. 816-537-4681.
  - AT&T, 215 North Spring, Independence, MO. 816-325-5610.
  - Time Warner, 6550 Winchester Avenue, Kansas City, MO. 913-643-1901.



**E & A CONSULTING GROUP, INC.**  
Engineering • Planning • Environmental & Field Services  
10909 Mill Valley Road, Suite 100 • Omaha, NE 68154  
Phone: 402.895.4700 • Fax: 402.895.3599  
www.eacg.com  
E&A Job #: 2018.037.006  
Missouri State Certificate of Authority # E-2014008210

**EXTRA SPACE STORAGE - LEE'S SUMMIT**  
 650 OLDHAM PARKWAY  
 LEE'S SUMMIT, MO

**Hernly ASSOCIATES**

1100 Rhode Island  
Lawrence, Kansas 66044  
785-749-5806  
FAX 785-749-1515

DRAWINGS

Date: 9/18/2018  
Drawn by: DRH  
Checked by: DRH  
Revisions:

**C4**

**GENERAL SITE CONSTRUCTION NOTES**

- City of Lee's Summit UDO and Design & Construction Manual requirements shall govern over other specifications and the Contractor shall perform in accord therewith.
- The Contractor shall check with the Owner for City approval of the project before starting work.
- Utilities are shown as a convenience for the Contractor. The locations of all aerial and underground utility facilities may not be indicated in these plans. Underground utilities, whether indicated or not, will be located and flagged by the utility companies at the Contractor's request. No excavation will be permitted in the area of the underground utilities until all facilities have been located and identified to the satisfaction of all parties and then only with extreme care to avoid any possibility of damages to the facilities.
- Erosion control improvements shall be constructed on this site, including inlet protection, silt fencing and a construction entrance. The Contractor shall be responsible for prompt reconstruction of any erosion control improvements disturbed by his operations. All disturbed erosion control improvements shall be fully reconstructed at the end of each working day prior to leaving the site. Separate payment will not be made for reconstruction of any erosion control improvements. Positive drainage in all work areas shall be maintained in the condition the construction site was in prior to Contractors arrival.
- Non-colored concrete pavement shall be cured using a white pigmented liquid membrane-forming curing compound that has been approved by the City of Lee's Summit. The minimum rate of application shall be 200 sq. ft. per gal. if a mechanical-powered sprayer is used and 100 sq. ft. per gal. if a hand powered sprayer is used.
- Water reducing admixtures shall be added to all hand-placed and finished concrete.
- A diamond edge saw blade shall be used for cutting all required contraction and longitudinal pavement joints.
- Concrete pavement shall be jointed in maximum 12.5' x 15' panels and shall be kept as square as possible. Joints shall be perpendicular to edges and radiuses, and shall not form angles less than 45 degrees or over 225 degrees.
- 6' sidewalk shall be jointed in 6'x6' panels, 5' sidewalk shall be jointed in 5'x5' panels.
- Backfill soils in utility trenches, around foundations, basement walls, and retaining walls shall be compacted to a minimum of 95% of the maximum dry density (ASTM D-698, Standard Proctor) at a moisture content between -3% and +4% of the optimum, or as specified in the Geotechnical Engineering Report. Lift thickness shall be appropriately matched to the type of compaction equipment used.
- Curb inlets shall be an APWA KCMC Type 2 Curb Inlet or a Nyloplast curb inlet with 2' x 3' diagonal flow grate, or approved equal in conformance with the City of Lee's Summit requirements.
- Grate inlet shall be a Nyloplast grate inlet with 2' x 3' rectangular grate, or approved equal in conformance with the City of Lee's Summit requirements.

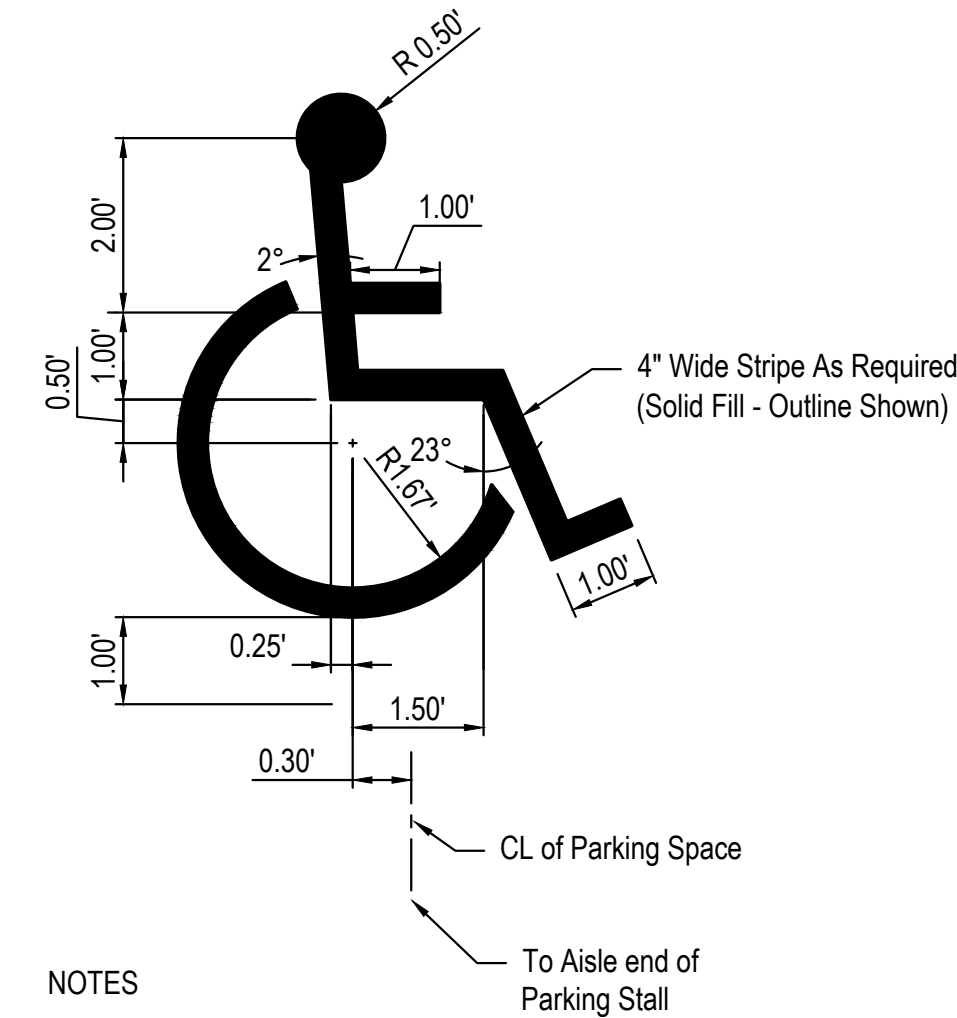

**NOTES**

- Paint Color by Surface:  

Pavement Surface	Paint Color
Concrete	Yellow
Bituminous	White
- Paint shall Conform to Federal Specification: TT-P-115 (2 Coats)

**HANDICAP PARKING LOT STENCIL DETAIL**

NOT TO SCALE

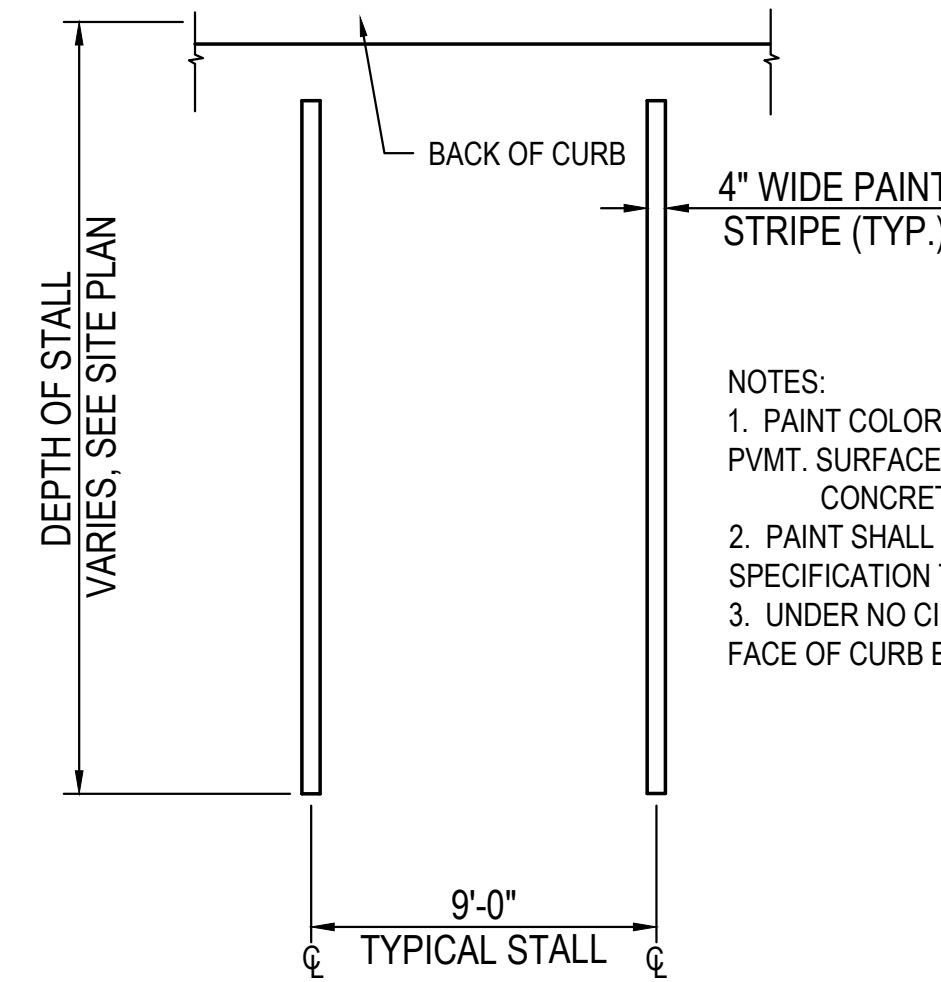

**PARKING STALL PAINT STRIPING**

NOT TO SCALE

- NOTES:**
- PAINT COLOR BY SURFACE:  
 PVMT. SURFACE PAINT COLOR  
 CONCRETE = SAFETY YELLOW
  - PAINT SHALL CONFORM TO FEDERAL SPECIFICATION TT-P-115 (2 COATS)
  - UNDER NO CIRCUMSTANCES SHALL FACE OF CURB BE PAINT STRIPED.

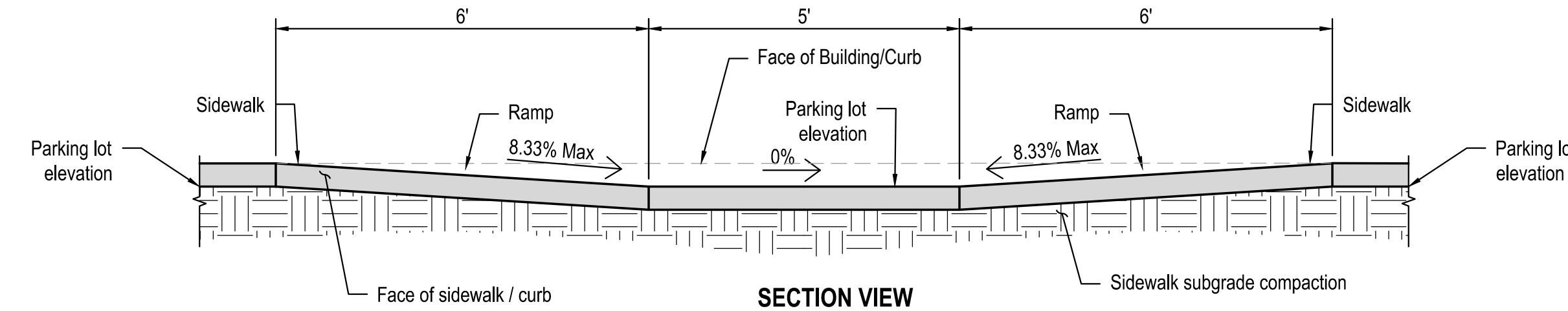

**SECTION VIEW**

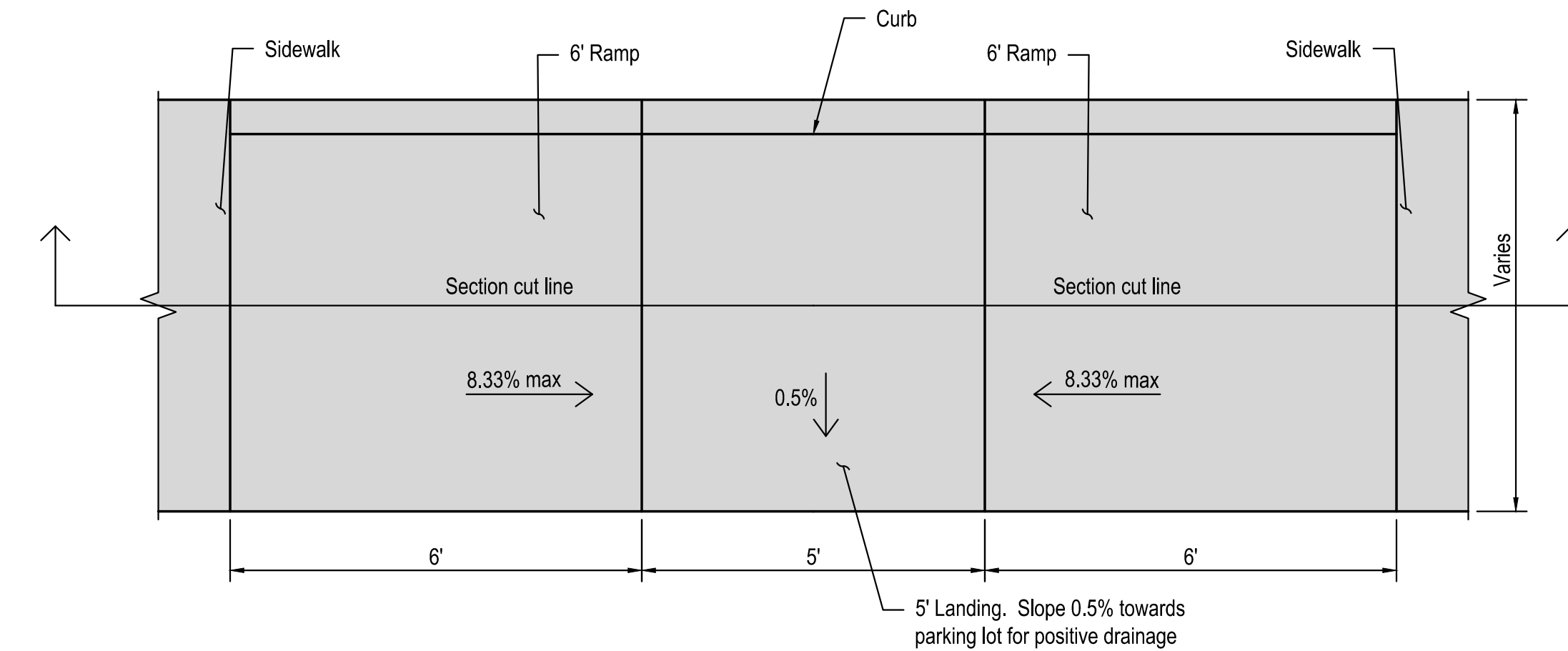

**PLAN VIEW**

**IN-LINE ADA CURB RAMP**

NOT TO SCALE

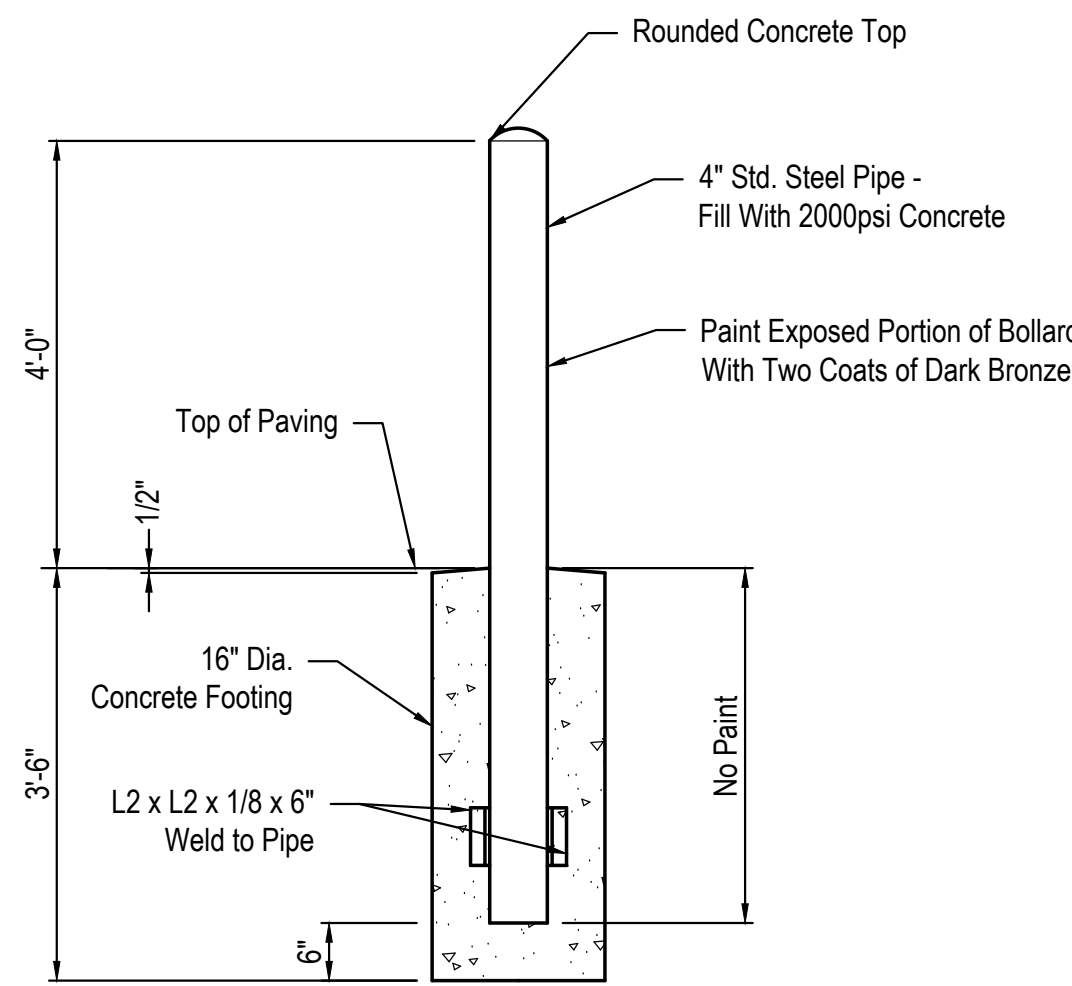

**BOLLARD DETAIL**

NOT TO SCALE

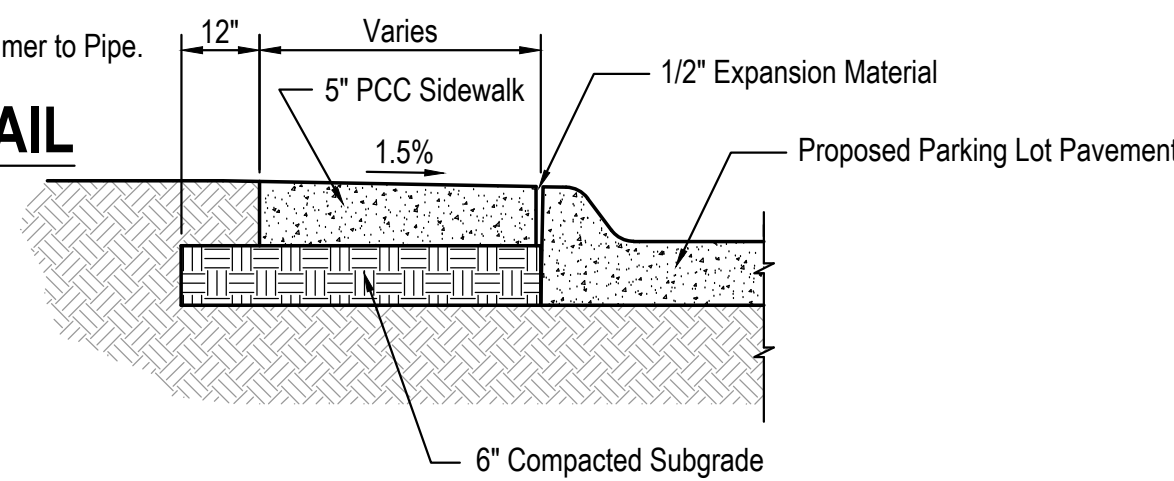

**TYPICAL SIDEWALK SECTION - ADJACENT TO CURB**

NOT TO SCALE

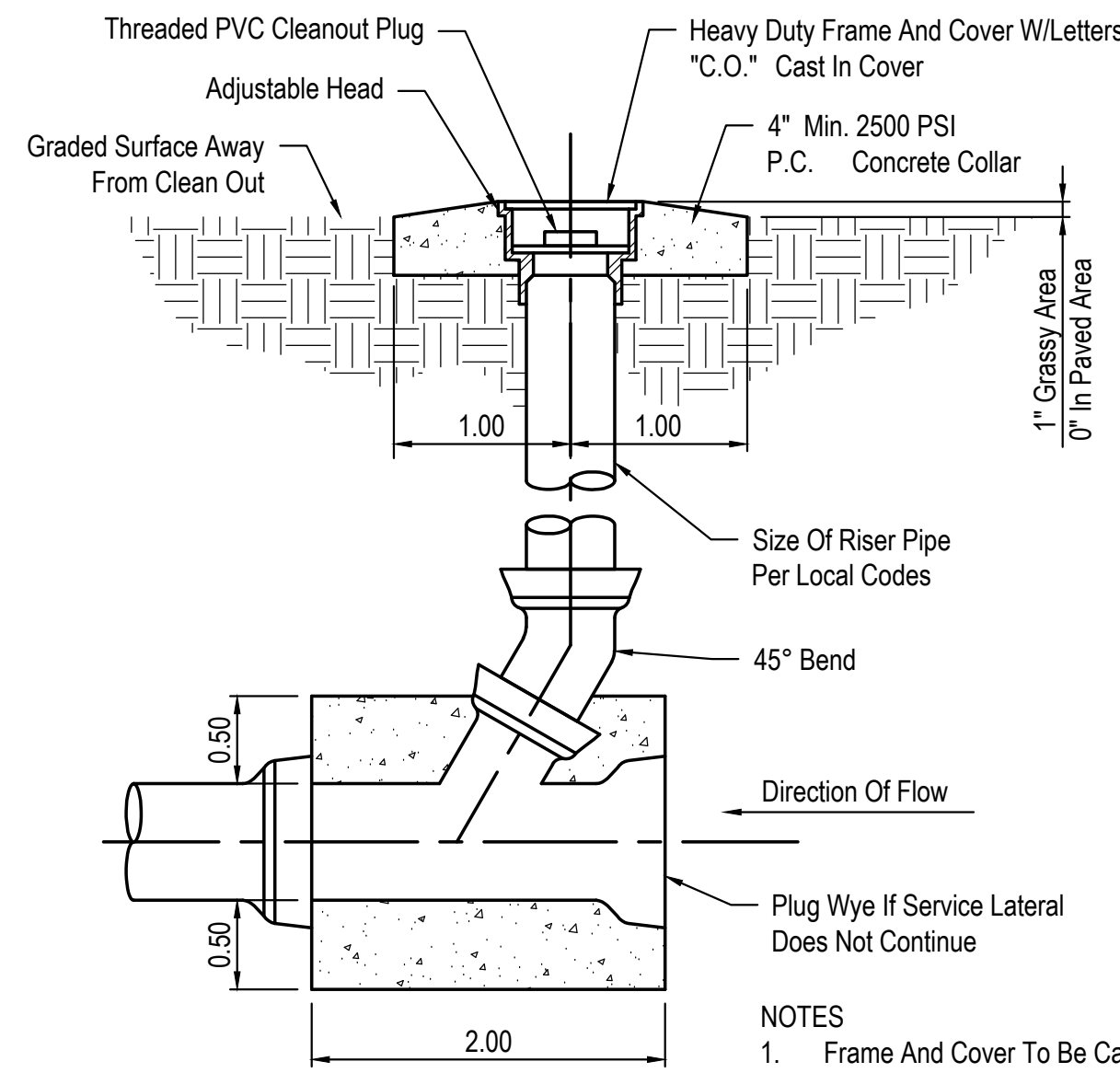

**SECTION**

**SEWER CLEANOUT DETAIL**

NOT TO SCALE

**NOTES**

- Frame And Cover To Be Cast Iron. Approx. Weight Is 70 Lbs.
- Cover To Have The Letters "C.O." Cast On Top
- Concrete Rest Block Shall Be 2'-0" Long x O.D. Of Pipe + 6" On Each Side.

mo1call.com 1-800-DIG-RITE  
 1-800-344-7483  
**Missouri811**  
 know what's below.  
 Call before you dig.  
 Dial: 811

STATE OF MISSOURI  
 David R. Harnisch, Jr.  
 Civil Engineer  
 MCH PE-2015003013  
 PROFESSIONAL ENGINEER

EXTRA SPACE STORAGE - LEE'S SUMMIT  
 650 OLDHAM PARKWAY  
 LEE'S SUMMIT, MO

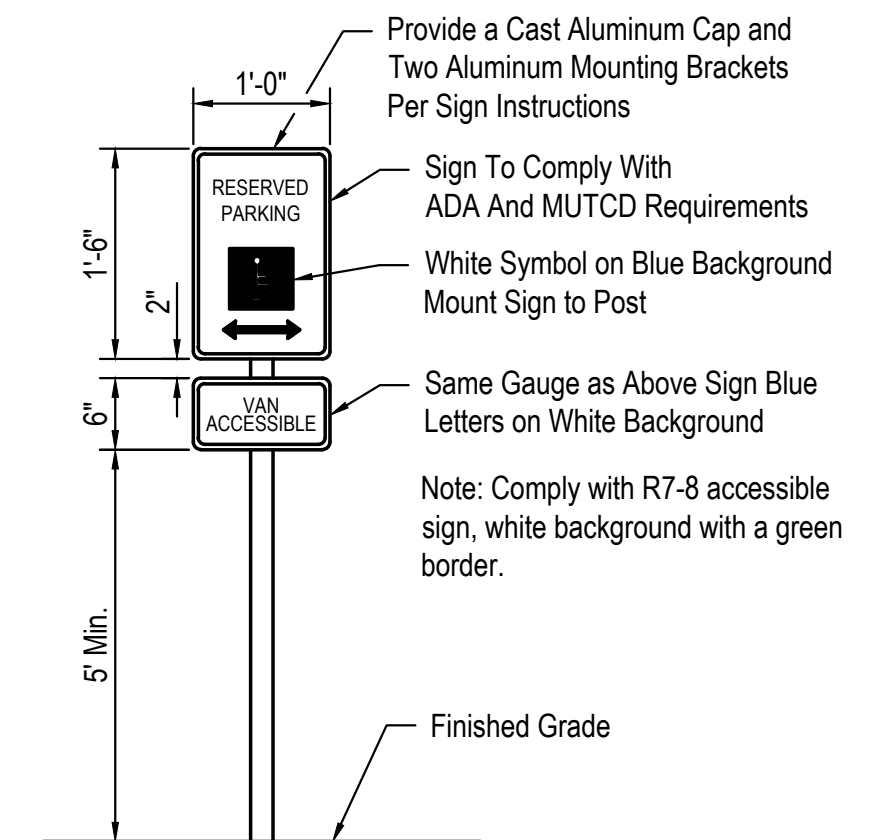

**HANDICAP PARKING SIGN**

NOT TO SCALE

**e+a**  
**E & A CONSULTING GROUP, INC.**  
 Engineering Answers

**E & A CONSULTING GROUP, INC.**  
 Engineering • Planning • Environmental & Field Services

10909 Mill Valley Road, Suite 100 • Omaha, NE 68154  
 Phone: 402.895.4700 • Fax: 402.895.3599  
 www.eacg.com  
 Missouri State Certificate of Authority # E-2014008210

E&A Job # :  
 2018.037.006

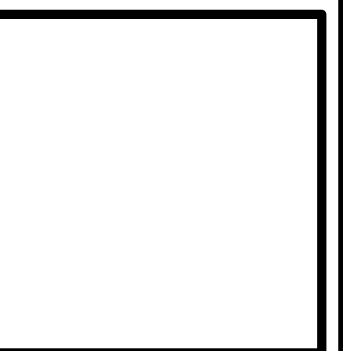

**Hernly ASSOCIATES**

1100 Rhode Island  
 Lawrence, Kansas 66044  
 785 - 749 - 5806  
 FAX 785 - 749 - 1515

DRAWINGS

Date: 9/18/2018  
 Drawn by: DRH  
 Checked by: DRH  
 Revisions:

C5

**NOTES & DETAILS**

SCALE AS NOTED

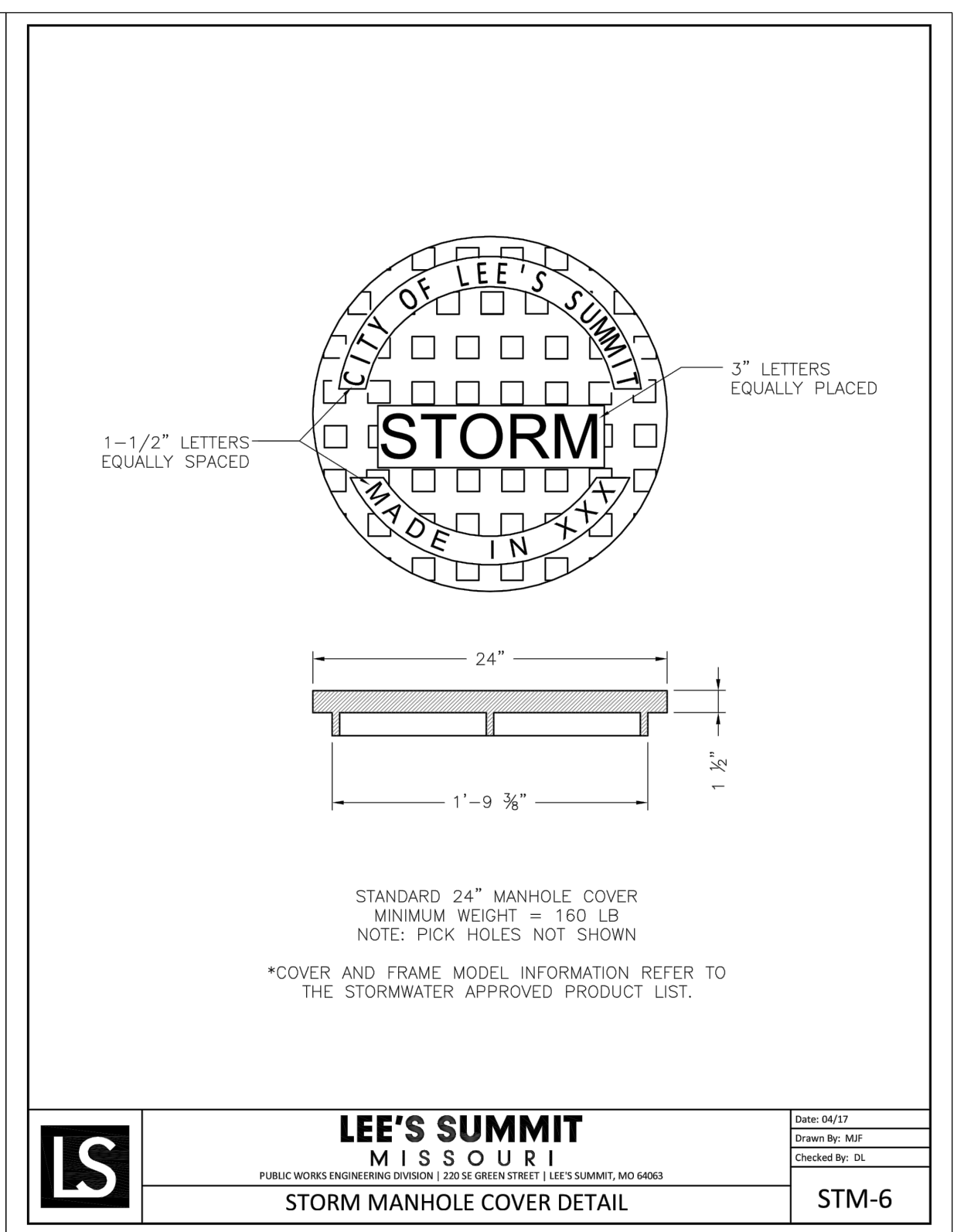
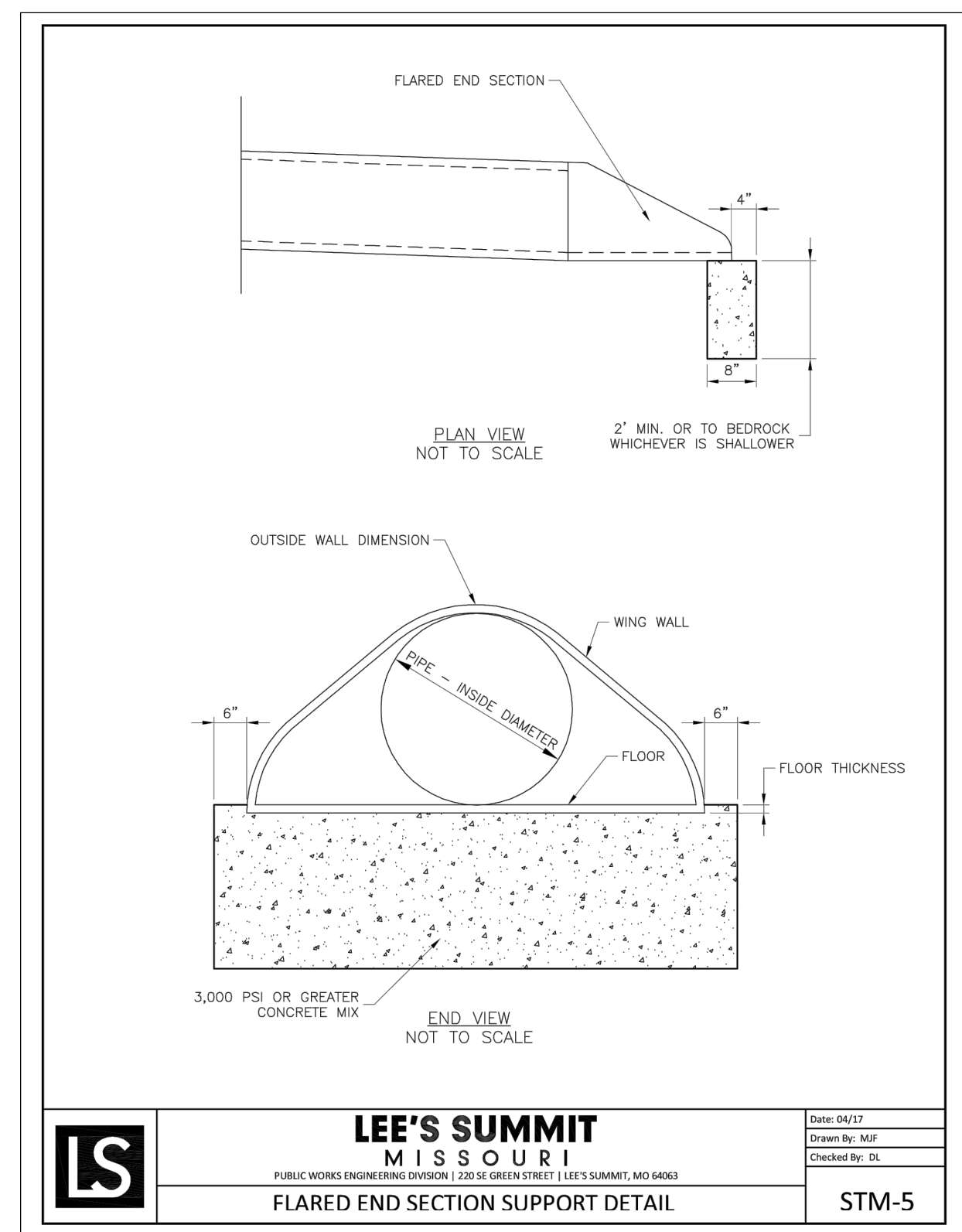
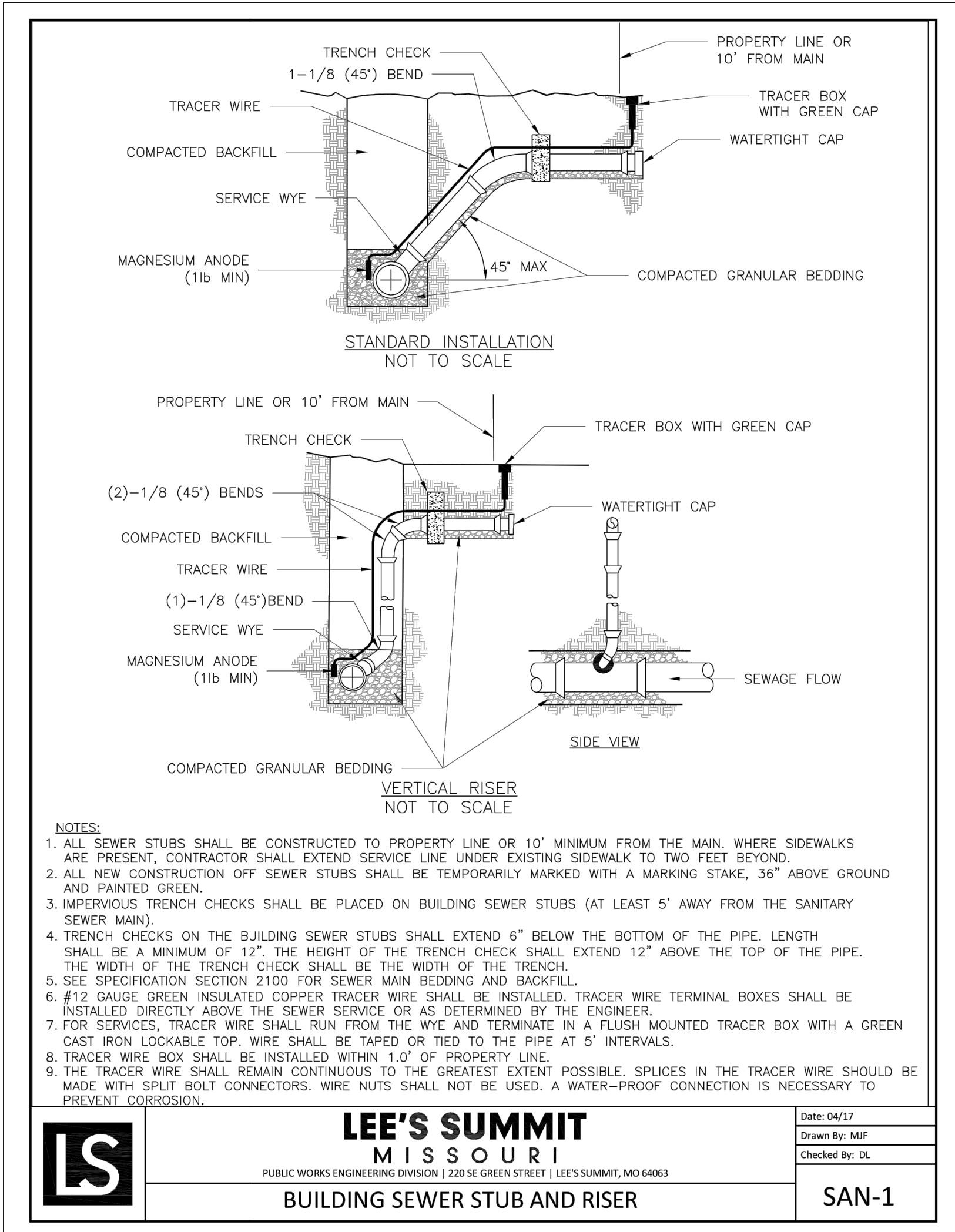
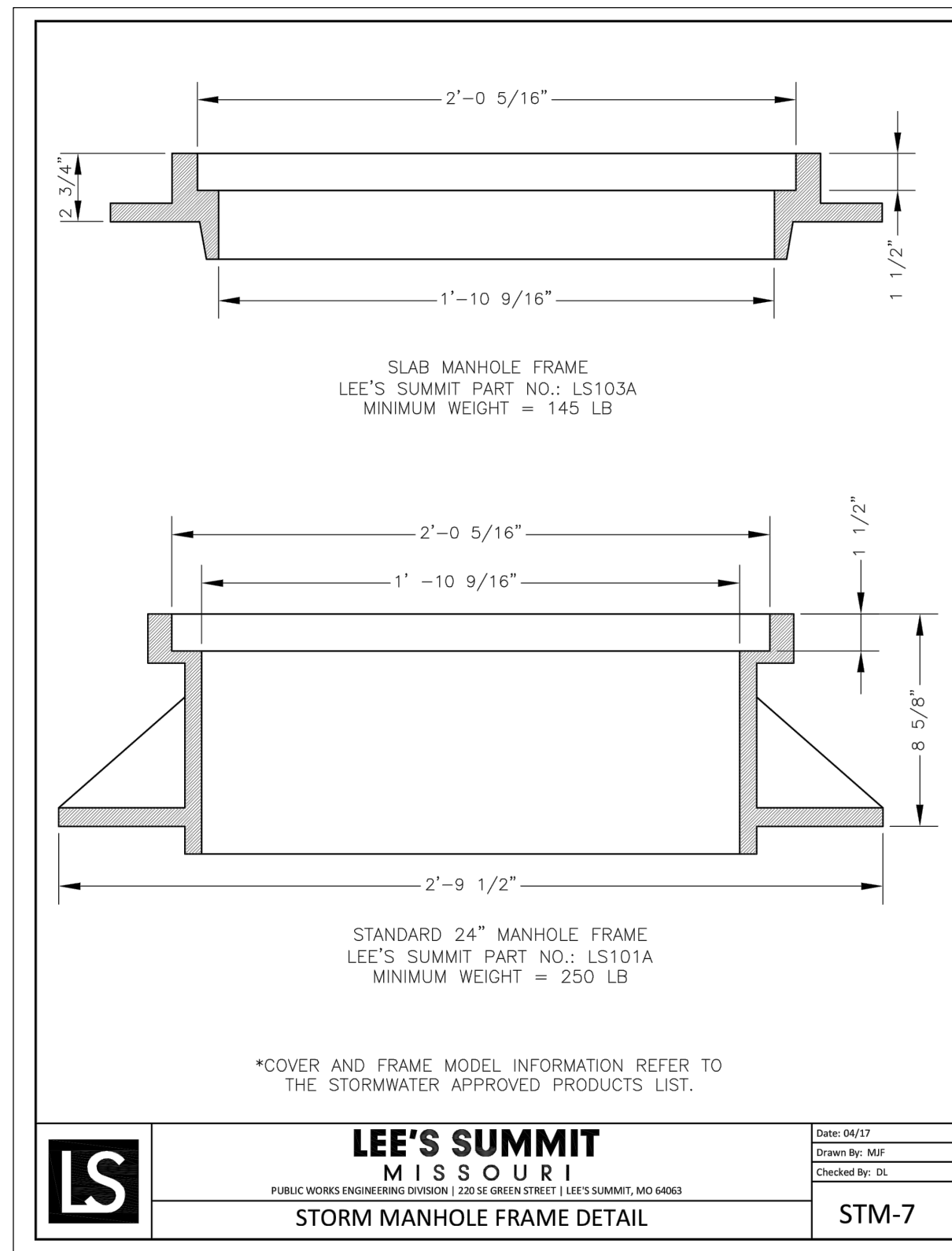
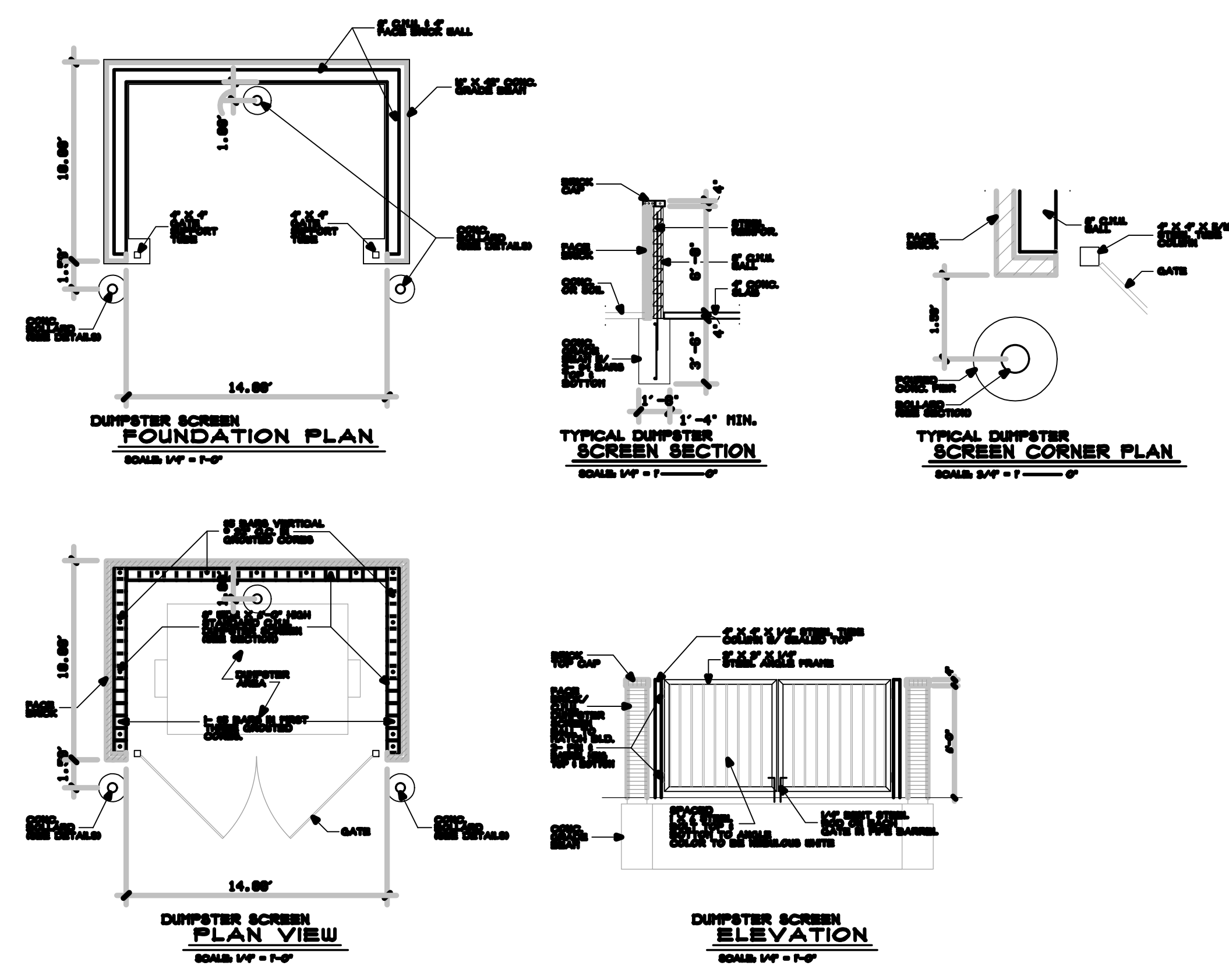

EXTRA SPACE STORAGE - LEE'S SUMMIT  
 650 OLDHAM PARKWAY  
 LEE'S SUMMIT, MO

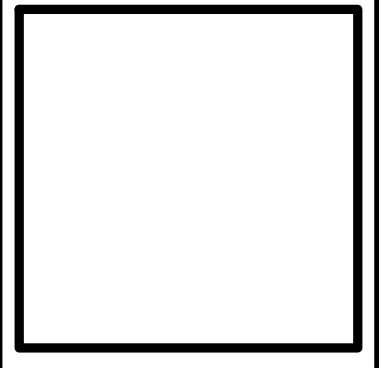

**Hernly ASSOCIATES**

1100 Rhode Island  
 Lawrence, Kansas  
 66044  
 785-749-5806  
 FAX 785-749-1515

DRAWINGS

Date: 4/18/2018  
 Drawn by: DRH  
 Checked by: DRH  
 Revisions:



**E & A CONSULTING GROUP, INC.**  
 Engineering • Planning • Environmental & Field Services

10909 Mill Valley Road, Suite 100 • Omaha, NE 68154  
 Phone: 402.895.4700 • Fax: 402.895.3599  
 www.eacg.com  
 Missouri State Certificate of Authority # E-2014008210

E&A Job # :  
 2018.037.006

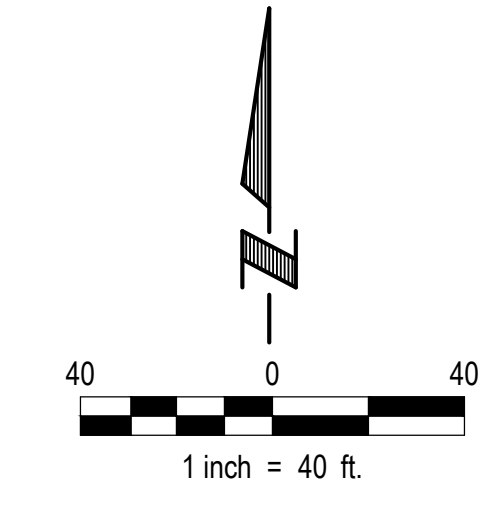
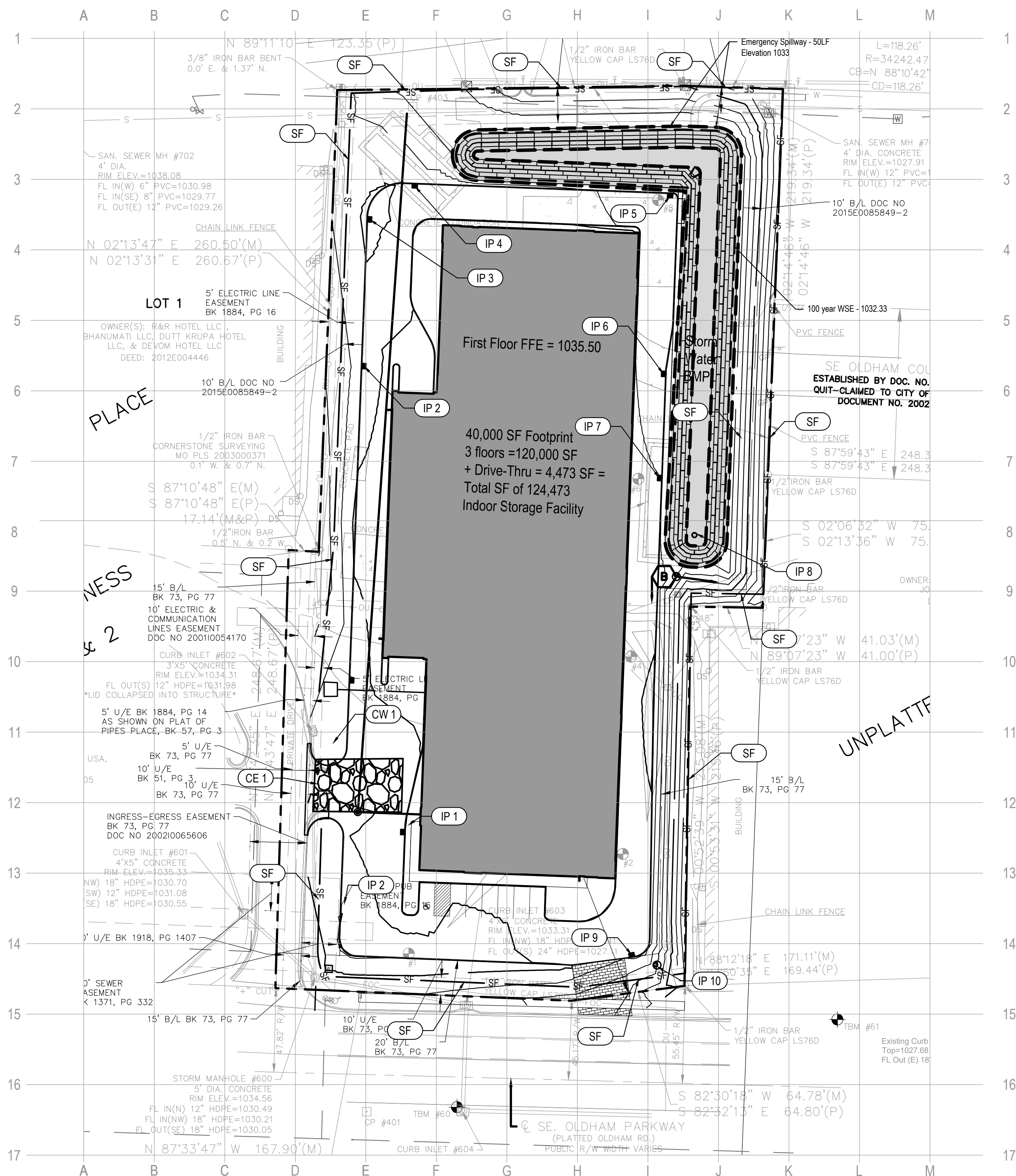

**LEGEND**

	Silt Fence
	Construction Entrance
	BMP Basin Extents
	GeoBlock Ground Improvement/ Emergency Fire Access
	Building Footprint(s)
	6' High Black Vinyl Coated Chain Link Fence, See Details Sheet C7
	Ridge Line
	Inverted Crown Line
	100 Year WSE
	Dry Detention Basin Perimeter
	Property Line

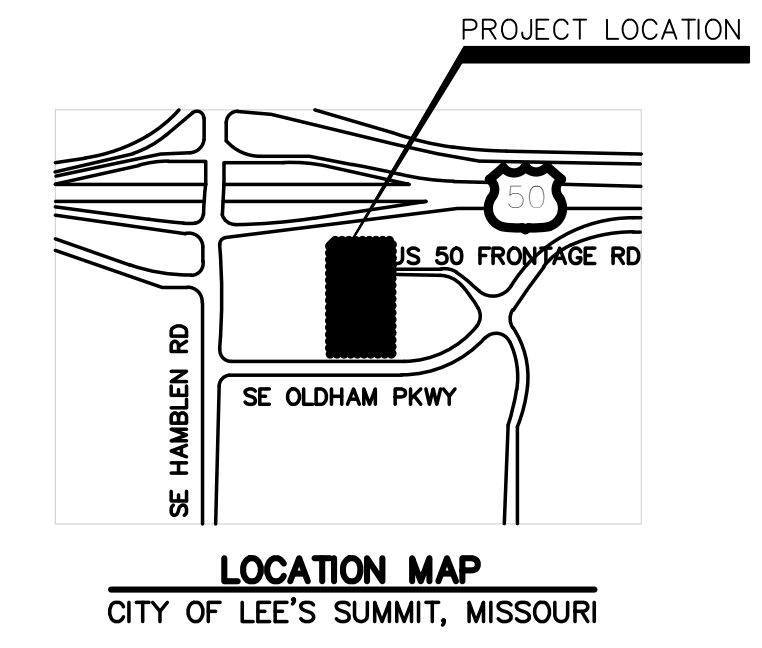

- SWPPP NOTES**
- Silt fence shall be constructed in 100' segments with 'J' hook ends. See Detail on this sheet.
  - Means of inlet protection shall be determined in the field by the contractor and shall be compliant with the City of Lee's Summit Standards. The inlet protection installed shall be sufficient in protecting the inlet from receiving any sediment or debris from construction activities.
  - Once inlet protection is removed all remaining sediment shall be cleaned away from the inlet and disposed of properly.
  - Finished grade shall be sodded and landscaped upon completion of construction activities. See landscape plan for more information.

**SEDIMENT & EROSION CONTROL REFERENCE NOTES**

CW1	Furnish and Install Concrete Washout Area. Use Outpak Washout or Engineer Approved Equal. See Detail on Sheet C9.
CE1	Construction Entrance
IP1	Furnish and Install Inlet Protection.*
IP2	Furnish and Install Inlet Protection.*
IP3	Furnish and Install Inlet Protection.*
IP4	Furnish and Install Inlet Protection.*
IP5	Furnish and Install Inlet Protection.*
IP6	Furnish and Install Inlet Protection.*
IP7	Furnish and Install Inlet Protection.*
IP8	Furnish and Install Inlet Protection.*
IP9	Furnish and Install Inlet Protection.*
IP10	Furnish and Install Inlet Protection.*
SF	Install Silt Fence in 100' Sections (max. length) with J-Hook Ends (Typ) *Install Inlet Protection on Additional Inlets as Necessary.

**EXTRA SPACE STORAGE - LEE'S SUMMIT**  
 650 OLDHAM PARKWAY  
 LEE'S SUMMIT, MO

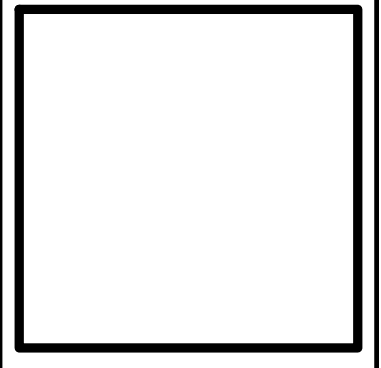

**Hernly ASSOCIATES**  
 1100 Rhode Island  
 Lawrence, Kansas 66044  
 785 - 749 - 5806  
 FAX 785 - 749 - 1515

**DRAWINGS**

Date:	9/18/2018
Drawn by:	DRH
Checked by:	DRH
Revisions:	



**E & A CONSULTING GROUP, INC.**  
 Engineering • Planning • Environmental & Field Services  
 10909 Mill Valley Road, Suite 100 • Omaha, NE 68154  
 Phone: 402.895.4700 • Fax: 402.895.3599  
 www.eacg.com  
 Missouri State Certificate of Authority # E-2014008210

E&A Job # :  
 2018.037.006

**MAINTENANCE SCHEDULE:**

The following Maintenance Schedule has been provided. The INSPECTOR must perform the Inspections. The OPERATOR/CONTRACTOR must perform all needed maintenance. Furthermore, all erosion control features requiring maintenance may not be listed below. The OPERATOR/CONTRACTOR and INSPECTOR must perform their respective duties on all BMP's that are not listed below as well.

- Construction Entrance** - The entrance shall be maintained in a condition which will prevent tracking or flow of sediment onto public rights-of-way. This may require periodic top dressing with additional stone or the washing and reworking of existing stone as conditions demand and repair and/or cleanout of any structures used to trap sediment. All materials spilled, dropped, washed, or tracked from vehicles onto roadways or into storm drains must be removed immediately. The use of water trucks to remove materials dropped, washed, or tracked onto roadways will not be permitted under any circumstances. Once every two weeks, whether a storm event has occurred or not, the measure shall be inspected and repairs made if needed.
- Silt Fence** - The maintenance measures are as follows; (2.1) silt fences shall be inspected immediately after each rainfall and at least daily during prolonged rainfall, any required repairs shall be made immediately; (2.2) close attention shall be paid to the repair of damaged silt fence resulting from end runs and undercutting; (2.3) should the fabric on a silt fence decompose or become ineffective prior to the end of the expected usable life and the barrier is still necessary, the fabric shall be replaced promptly; (2.4) sediment deposits must be removed when the level of deposition reaches approximately one-half the height of the barrier; (2.5) once every two weeks, whether a storm event has occurred or not, the measure shall be inspected and repairs made if needed and (2.6) any sediment deposits remaining in place after the silt fence is no longer required shall be dressed to conform to the existing grade, prepared and seeded.
- Storm Drain Inlet Protection** - The maintenance measures are as follows: (3.1) structures shall be inspected after each rain and repairs made as necessary; (3.2) structures shall be removed and the area stabilized when the remaining drainage area has been properly stabilized; (3.3) once every two weeks, whether a storm event has occurred or not, the measure shall be inspected and repairs made if needed.
- Temporary Diversion Dike** - The measure shall be inspected after every storm and repairs made to the dike, flow channel, outlet or sediment trapping facility, as necessary. Once every two weeks, whether a storm event has occurred or not, the measure shall be inspected and repairs made if needed. Damages caused by construction traffic or other activity must be repaired before the end of each working day.
- Temporary Fill Diversion** - Since the practice is temporary and under most situations will be covered the next working day. The maintenance required should be low. If the practice is to remain in use for more than one day, an inspection shall be made at the end of each work day and repairs made to the measure if needed. The OPERATOR/CONTRACTOR should avoid the placement of any material over the structure while it is in use. Construction traffic should not be permitted to cross the diversion.
- Temporary Sediment Trap** - The maintenance measures are as follows: (6.1) sediment shall be removed and the trap restored to its original dimensions when the sediment has accumulated to one half the design volume of the wet storage, sediment removal from the basin shall be deposited in a suitable area and in such a manner that it will not erode and cause sedimentation problems; (6.2) filter stone shall be regularly checked to ensure that filtration performance is maintained, stone choked with sediment shall be removed and cleaned or replaced; and (6.3) the structure should be checked regularly to ensure that it is structurally sound and has not been damaged by erosion or construction equipment, the height of the stone outlet should be checked to ensure that its center is at least 1 foot below the top of the embankment.
- Temporary Sediment Basin** - The basin embankment should be checked regularly to ensure that it is structurally sound and has not been damaged by erosion or construction equipment. The emergency spillway should be checked regularly to ensure that its lining is well established and erosion-resistant. The basin should be checked after each runoff producing rainfall for sediment cleanout and trash removal. When the sediment reaches the cleanout level, it shall be removed and properly disposed of.
- Temporary Seeding** - Areas which fail to establish vegetative cover adequate to prevent rill erosion will be re-seeded as soon as such areas are identified. Control weeds by mowing.
- Permanent Seeding** - The maintenance measures are as follows: (9.1) in general, a stand of vegetation cannot be determined to be fully established until it has been maintained for one full year after planting; (9.2) new seedlings shall be supplied with adequate moisture, supply water as needed, especially late in the season, in abnormally hot or dry conditions, or on adverse sites, water applications shall be controlled to prevent excessive runoff; (9.3) inspect all seeded areas for failures and make necessary repairs, replacements, and reseedings within the planting season, if possible; (9.3a) if stand is inadequate for erosion control, over seed and fertilize using half of the rates originally specified; (9.3b) if stand is 60% damaged, re-establish following seedbed and seeding recommendations; (9.3c) if stand has less than 40% cover, re-evaluate choice of plant materials and quantities of lime and fertilizer, the soil must be tested to determine if acidity or nutrient imbalances are responsible, re-establish the stand following seedbed and seeding recommendations.
- Mulching** - All mulches and soil coverings should be inspected periodically (particularly after rainstorms) to check for erosion. Where erosion is observed in mulched areas, additional mulch should be applied. Nets and mats should be inspected after rainstorms for dislocation or failure. If washouts or breakage occur, reinstall netting or matting as necessary after repairing damage to the slope or ditch. Inspections should take place until grasses are firmly established. Where mulch is used in conjunction with ornamental plantings, inspect periodically throughout the year to determine if mulch is maintaining coverage of the soil surface; repair as needed.
- Soil Stabilization Blankets & Matting** - All soil stabilization blankets and matting should be inspected periodically following installation, particularly after rainstorms to check for erosion and undermining. Any dislocation or failure should be repaired immediately. If washouts or breakage occurs, reinstall the material after repairing damage to the slope or ditch. Continue to monitor these areas until which time they become permanently stabilized; at that time an annual inspection should be adequate.
- Street Cleaning/Sweeping** - The maintenance measures are as follows; (12.1) evaluate access points daily for sediment tracking; (12.2) when tracked or spilled sediment is found on paved surfaces, it will be removed daily, during times of heavy track-out such as during rains, cleaning may be done several times throughout the day; (12.3) unknown spills or objects will not be mixed with the sediment; and (12.4) if sediment is mixed with other pollutants, it will be disposed of properly at an authorized landfill.
- All OPERATORS/CONTRACTORS must confirm with the APPLICANT that any and all applicable governmental approvals have been received prior to the start of work.
- BMP's may not be removed without INSPECTOR and City of Lee's Summit approval.

**ACTIVITY**

Install all BMP's needed and associated with the Grading Phase such as stabilized construction entrances, silt basins, riser pipes, outlet pipes, silt traps, silt fence, diversions, terraces, etcetera.

Proceed with stripping of existing vegetation and grading in accordance with the grading plan, while disturbing no more than is necessary.

Proceed with infrastructure installation.

Implement the installation of Temporary Seeding, Permanent Seeding, and/or Mulching.

Implement the Installation all BMP's needed and associated with the Building Phase.

Proceed with removal of BMP's.

**SCHEDULE**

Prior to any stripping of existing vegetation or grading.

After installing all BMP's needed and associated with the Grading Phase. Furthermore, INSPECTOR approval must be obtained before the start of any stripping of existing vegetation or grading.

Infrastructure installation must occur prior to any lot development.

Stabilization measures must be initiated as soon as possible in portions of the site where construction activities have temporarily or permanently ceased, but in no case more than 14 days after the construction activity in that portion of the site has temporarily or permanently ceased.

Building Phase BMP's must be installed concurrently with lot development.

BMP's may not be removed until each impacted drainage basin has been fully developed. Full development shall mean installation of pavement, buildings, and utilities, landscaping, and fully established permanent seeding. Furthermore, INSPECTOR approval must be obtained before the removal of any BMP's.

**STORM WATER POLLUTION PREVENTION PLAN GENERAL NOTES**

- Project procedures and materials shall conform to the following publication and any additions thereto: APWA KANSAS CITY METRO CHAPTER SECTION 2150- EROSION AND SEDIMENT CONTROL, as well as the erosion and sediment control details. These can be found at the following location: <http://kcmetro.apwa.net/PageDetails/439>. City of Lee's Summit standards shall control where they are more stringent.
- Operators/Contractors shall comply with noise and dust control ordinances.
- Operators/Contractors shall locate existing utilities prior to the start of work. (ONE CALL 1-800-344-7483).
- Barricades shall conform to the "MANUAL ON UNIFORM TRAFFIC CONTROL DEVICES" (MUTCD) and City of Lee's Summit Barricading Guidelines.
- Operators/Contractors shall be responsible for compliance with OSHA regulations.
- Operators/Contractors shall confirm with the Applicant that all applicable governmental approvals have been received prior to the start of work.
- The Applicant and Inspector shall comply with all applicable government regulations to minimize the potential for erosion and pollution.
- Operators/Contractors shall perform construction activities as directed by the Applicant, Inspector, and government Regulators to minimize the potential for erosion and pollution.
- Each Operator/Contractor shall monitor silt fencing and other best management practices (BMP's), within their areas of responsibility, and install additional BMP's as necessary and as directed by the Inspector.
- Each Operator/Contractor shall periodically remove accumulated sediment from temporary sediment traps, temporary sediment basins, behind silt fences, and other erosion control measures that store sediment, within their areas of responsibility, when necessary and as directed by the Inspector.
- Each Operator/Contractor shall build stabilized construction entrances, within their areas of responsibility and as defined within the SWPPP. Each Operator/Contractor shall monitor and maintain stabilized construction entrances within their areas of responsibility as needed or as directed by the Inspector. Operators/Contractors shall not use any other access to the site or allow others to use alternate access points.
- Each Operator/Contractor shall maintain and perform preventative maintenance on each Best Management Practice (BMP), within their areas of responsibility, to ensure their function. The Inspector shall ensure preventative maintenance is being performed.
- BMP's shall be kept in working order. Each Operator/Contractor shall repair any defects or damages, within their areas of responsibility, at or before the end of each working day or as directed by the Inspector.
- BMP's may not be removed without Inspector and applicable governmental approvals.
- Each Operator/Contractor shall be responsible for adhering to BMP's within their areas of responsibility.
- In the event of a release of oil or hazardous substance, Operators/Contractors shall comply with the requirements of the Missouri Department of Natural Resources for notification, containment, investigation, remedial action and disposal. Guidelines can be found at the following location: <https://dnr.mo.gov/pubs/pub212.pdf>.
- The Applicant, Inspector, and Contractors/Operators shall ensure temporary diversion dikes and temporary fill diversions are constructed as shown within the SWPPP and as necessary to properly control pollutant discharge. Temporary diversion dikes and temporary fill diversions shall be installed at the end of each working day, prior to all rain events, and as directed by the Inspector.
- The Applicant, Inspector, and/or Operators/Contractors shall allow government regulators access to the site for inspections at any time, at the implementing Agency's discretion.
- The Applicant, Inspector, and Contractors/Operators must initiate stabilization measures, such as temporary seeding, permanent seeding, and/or mulching, as soon as possible on portions of the site where construction activities have temporarily or permanently ceased, but in no case more than 14 days after construction activity on that portion of the site where work has ceased. Temporary seeding, permanent seeding and mulching BMP's presented within the APWA Kansas City Metro Chapter Section 2150- Erosion and Sediment Control, as well as the Erosion and Sediment Control Details. These can be found at the following location: <http://kcmetro.apwa.net/PageDetails/439>.
- For dust control, the Applicant, Inspector, and Contractors/Operators may use the following measures, singularly or in combination: establish temporary seeding, establish permanent seeding, mulch in areas subject to little or no construction traffic; irrigate stripped areas and/or haul roads; reduce vehicular speed on haul roads; or other options as directed by the Inspector.
- The Applicant, Inspector, and Contractors/Operators shall ensure sediment transported onto public streets is removed as needed, prior to rain events and, at a minimum, at the end of each working day. Sediment shall be shoveled and/or swept from the street and disposed of in a manner that prevents stormwater contamination.
- The Applicant, Inspector, and Contractors/Operators shall adhere to all good housekeeping BMP's. Good housekeeping BMP's focus on keeping the work site clean and orderly while handling materials and waste in a manner that eliminates the potential for pollutant runoff. Good housekeeping BMP's such as sanitary waste management, solid waste management, material delivery & storage, street cleaning/sweeping, and vehicle & equipment fueling shall be addressed when applicable.
- To better inform all concerned parties about the existence of the SWPPP, the Applicant, Inspector, and Contractors/Operators shall ensure an easily visible and legible sign be prominently posted at conspicuous locations near site entry points.
- The SWPPP documents are essential and a requirement in one part is binding as though occurring in all. The documents describe and provide the complete SWPPP. The Applicant, Inspector, and/or Contractors/Operators may not take advantage of any SWPPP errors or omissions. The inspector shall notify the Applicant, Designer, and Contractors/Operators promptly of any omissions or errors within one business day of discovery. The Applicant shall instruct the Designer to make any corrections necessary to fulfill the overall intent of the SWPPP documents. In the case of a discrepancy between parts of the SWPPP documents, the most stringent requirement shall rule.

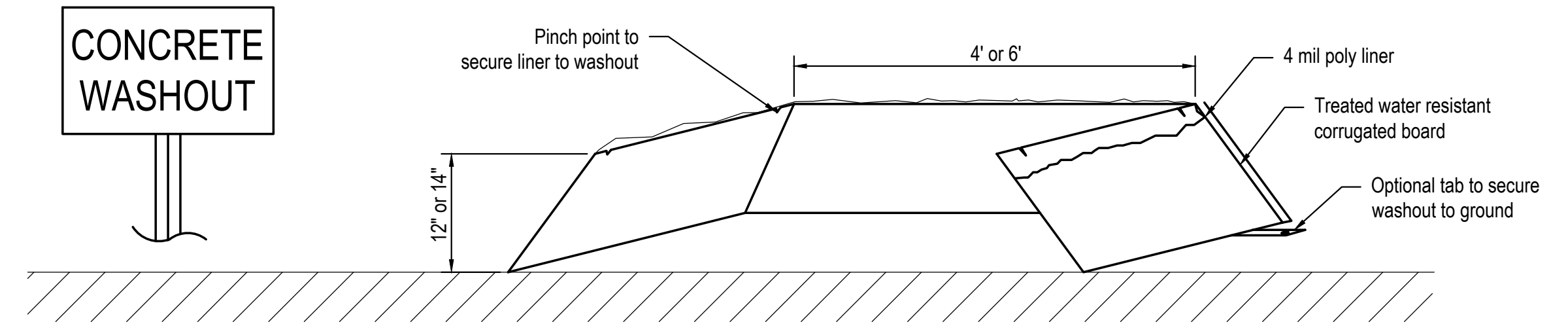

**NOTES:**

- The concrete washout area shall be installed prior to any concrete placement on this project. Install washout area on a level surface. use Disposable Concrete Washout or approved equal.
- Signs shall be placed as necessary to clearly indicate the location of the concrete washout.
- The concrete washout area will be replaced as necessary to maintain capacity for waste concrete and other liquid waste.
- Washout residue shall be removed from the site and disposed of at an approved waste site.
- Do not mix excess amounts of fresh concrete or cement on-site.
- Do not wash out concrete trucks into storm drains, open ditches, streets, or streams.
- Do not dump excess concrete in non-designated dumping areas.
- Locate washout area at least 50' (15 meters) from storm drains, open ditches, or waterbodies.
- Wash out wastes into the Washout as shown where the concrete can set, be broken up, and then disposed of properly.

**CONCRETE WASHOUT**

NOT TO SCALE

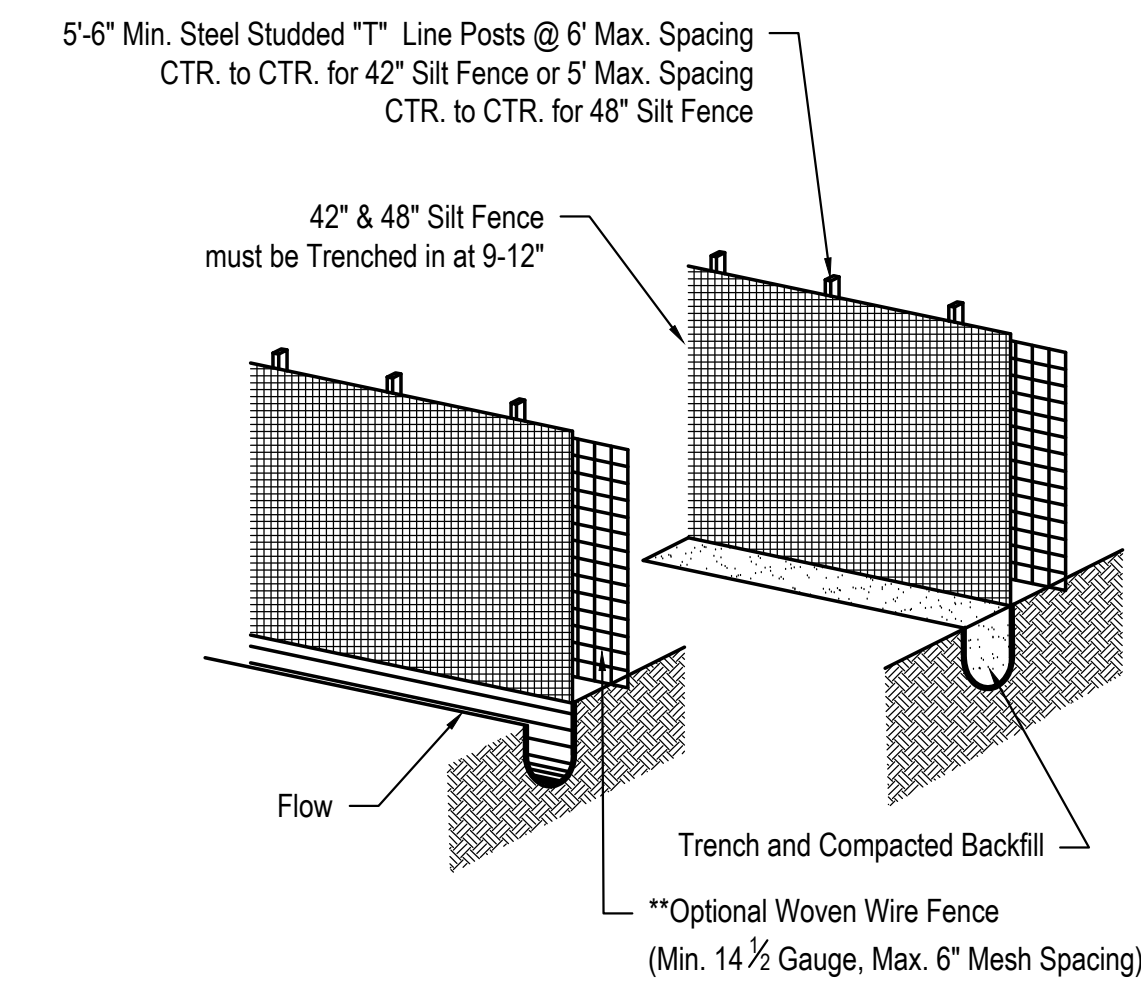

**NOTES:**

- Acceptable silt fence specifications- AOS (#20 - 50 Sieve), Water Flow Rate (50 gpm/ sq. ft. - 125 gpm/ sq.ft), Tensile Strength (Grab) - (Min. 120 Warp or greater and Elongation (5-25%).
- On each new run of silt fence spray paint the beginning of the run with 0+00 and spray paint the end with the date of installation and LF of the run.
- Silt fence should be securely fastened to each steel support post or to woven wire which is in turn attached to the steel fence posts. A minimum of 3 ties are required for each post. To be located in the top 12" of the silt fence.
- Steel posts which support the silt fence shall be installed on a slight angle toward the anticipated runoff source. (Incline all posts 20° Max. from vertical, toward flow)
- Silt fence shall be trenched in with a silt fence flow so that the downslope face of the trench is flat and perpendicular to the line of flow.
- Silt fence shall be removed when it has served its usefulness so as not to block or impede storm flow or drainage.
- Sediment trapped by this practice shall be uniformly distributed on the source area prior to topsoling.

**SILT FENCE**

NOT TO SCALE

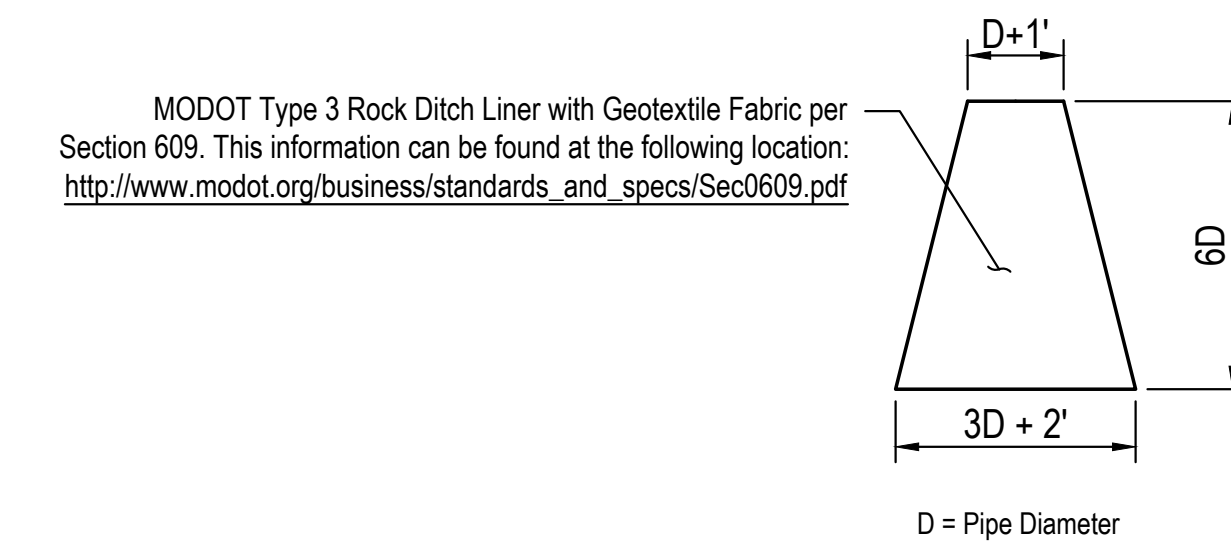

**E & A CONSULTING GROUP, INC.**  
Engineering • Planning • Environmental & Field Services

10909 Mill Valley Road, Suite 100 • Omaha, NE 68154  
Phone: 402.895.4700 • Fax: 402.895.3599  
www.eaacg.com  
Missouri State Certificate of Authority # E-2014008210

E&A Job # :  
2018.037.006



David R. Harnisch, Jr.  
Civil Engineer  
MO# PE-2015003013

EXTRA SPACE STORAGE - LEE'S SUMMIT  
650 OLDHAM PARKWAY  
LEE'S SUMMIT, MO

**Hernly ASSOCIATES**

1100 Rhode Island  
Lawrence, Kansas 66044  
785 - 749 - 5806  
FAX 785 - 749 - 1515

DRAWINGS

Date: 9/18/2018  
Drawn by: DRH  
Checked by: DRH  
Revisions:

C8

**STORM WATER POLLUTION PREVENTION PLAN NOTES & DETAILS**

SCALE AS NOTED



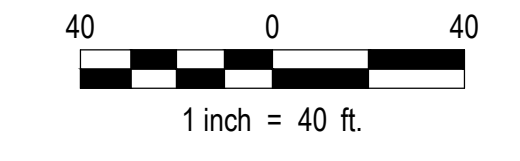
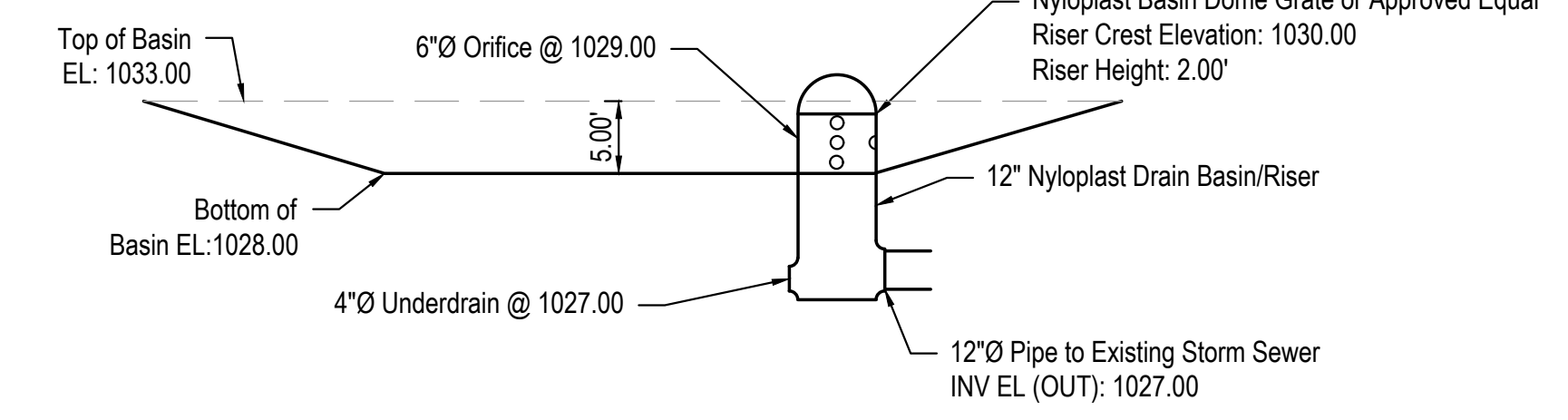
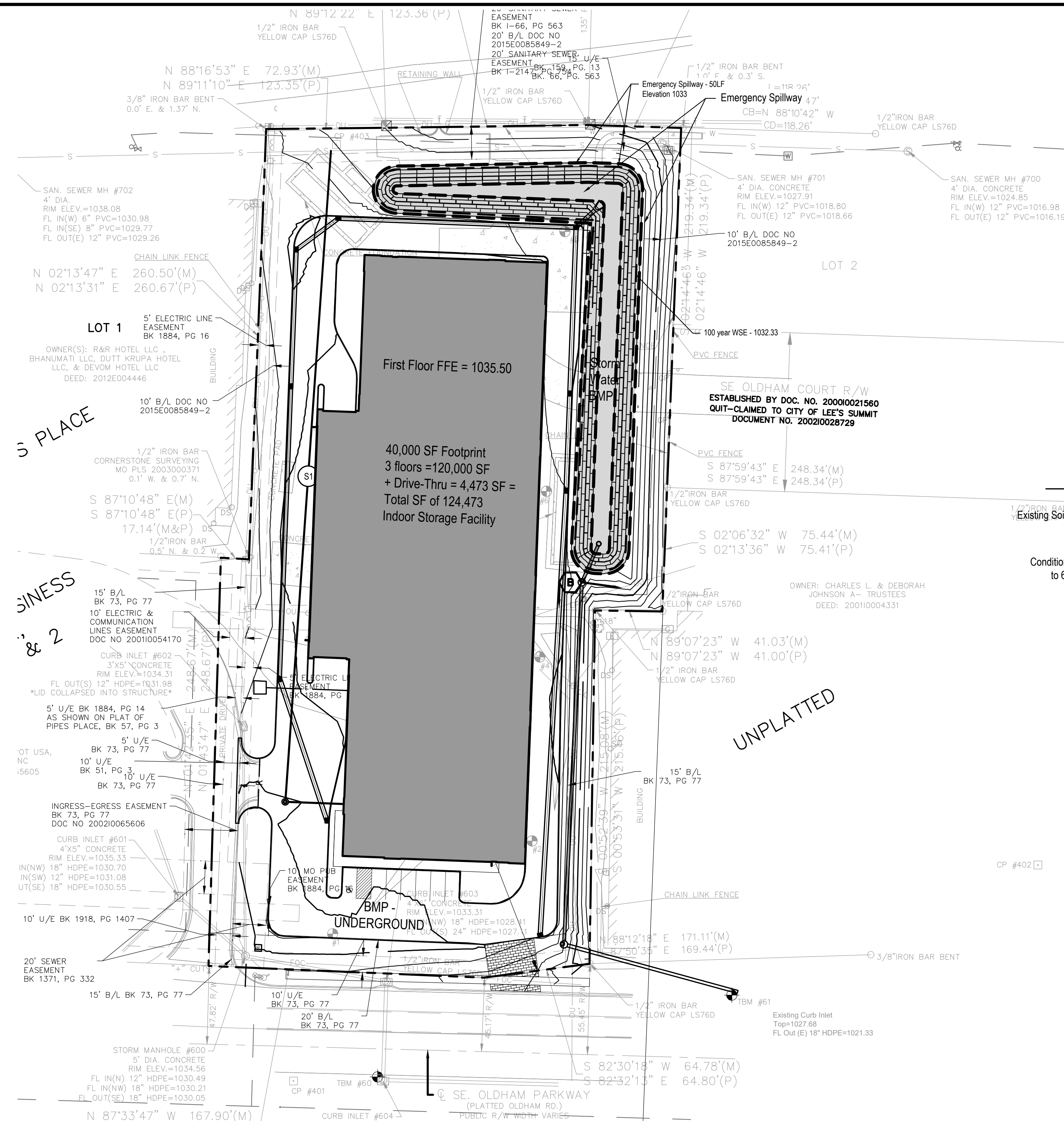

**LEGEND**

- Existing Contours
- Proposed Contours
- Ridge Line
- Inverted Crown Line
- Dry Detention Basin Perimeter
- 100 year WSE Extents
- Limits of Dry Detention Basin Seeding
- GeoBlock Ground Improvement/ Emergency Fire Access
- Building Footprint(s)
- 6' High Black Vinyl Coated Chain Link Fence, See Details Sheet C7
- Property Line

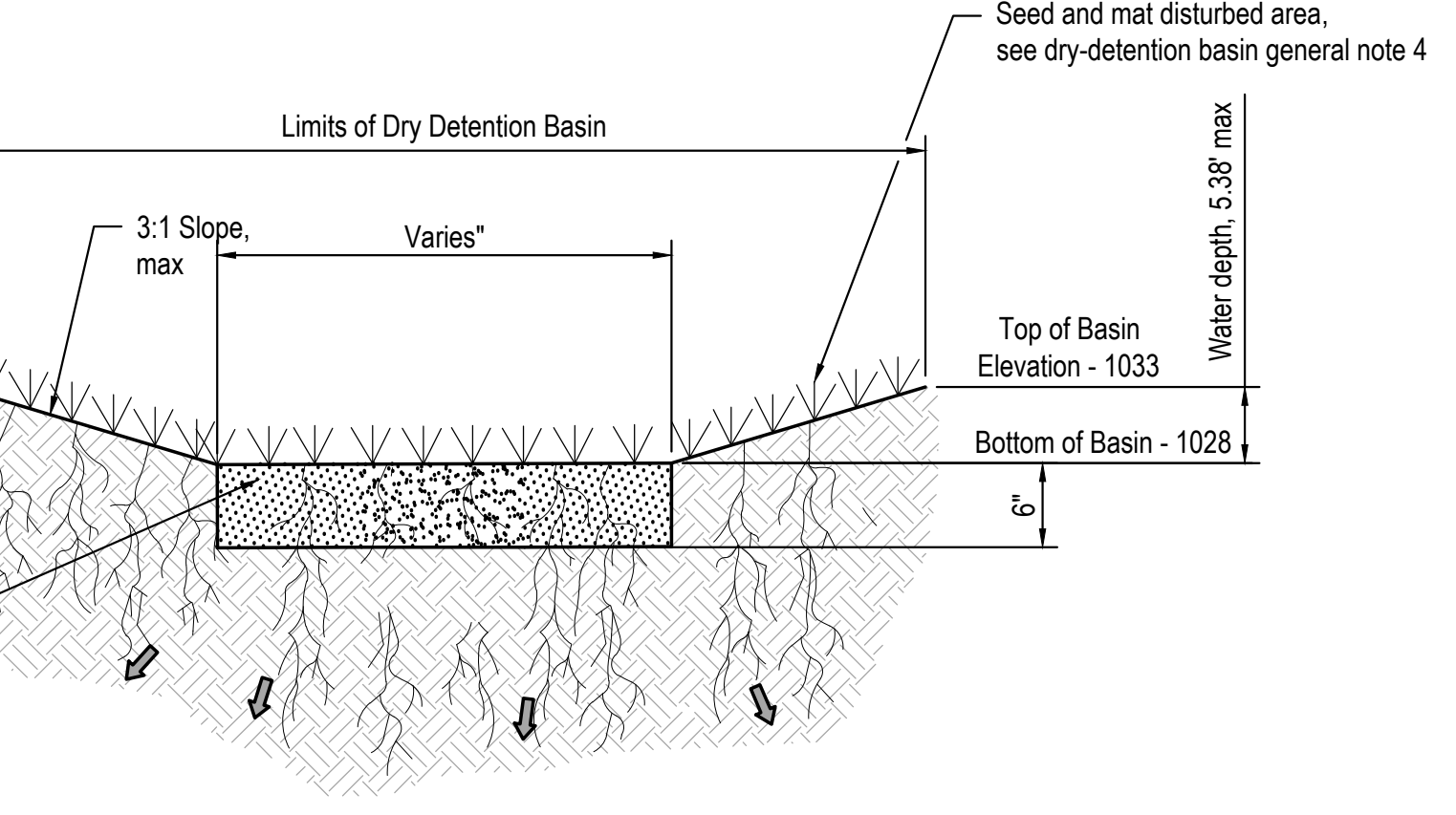

- DRY-DETENTION BASIN GENERAL NOTES**
- Scarify bottom and sides of basin and over excavated area to a depth of 6" prior to placement of amended soils.
  - Contractor shall work to minimize compaction by limiting construction traffic and equipment size within the limits of the basin.
  - Basin seed mixture shall be Superturf II NO RYE (sod grower) lateral spread tall fescue KY Bluegrass Mixture from United Seeds, Inc. Planting method and seeding rate shall be 10 lbs per 1,000 sq. ft. Seeding dates: December - March. Seed to be covered w/ matting, North American Green S-150, or approved equal, installed per manufacturer's recommendation or approved equal.
  - Conditioned soil: incorporate 1"-2" of compost in upper 6" of the basin bottom by means of a tiller.
  - Contractor to protect from overland silt and runoff during and after construction until fully stabilized (80% vegetative cover), (Subsidiary)

**PCSMP BMP INFORMATION**

BMP ID.	DRAINAGE AREA (AC)	1.37" VOLUME (CFS)	1.37" Detention Time (HRS)	DESCRIPTION	LOCATION
BMP 1	2.8800	2,086.00	20.53	Dry Storm Water Detention Basin	Lat: 38.902013°N/ Long: 94.360642°W

\*STORMTECH MAINTENANCE REQUIREMENTS SHALL BE PER MANUFACTURER RECOMMENDATIONS.  
\*\*SEE BASIN DETAIL THIS SHEET

**DRY DETENTION BASIN/POND MAINTENANCE TASKS AND SCHEDULE**

TASK	SCHEDULE
REMOVE DEBRIS FROM SIDE SLOPE AND TRASH RACK.	MONTHLY
OUTLET/INLET INSPECTION AND CLEANOUT	MONTHLY
BANK MOWING AND INSPECTION/STABILIZATION OF ERODED AREAS	MONTHLY
BASIN INSPECTION AND CLEANOUT	ANNUALLY - REMOVE SEDIMENT WHEN 25% OF STORAGE VOLUME HAS BEEN LOST.
REMOVE WOODY VEGETATION ALONG EMBANKMENT.	ANNUALLY
INSPECT FOR STRUCTURAL DAMAGE/LEAKES.	ANNUALLY
REPLACE BROKEN PIPES	AS NEEDED
REPLACE FILTRATION RIP RAP THAT IS CHOKED WITH SEDIMENT	AS NEEDED
SECURITY	AS NEEDED

**DRY DETENTION BASIN NOTES**

BASIN	BOTTOM ELEV.	TOP ELEV.	OUTLET PIPE DIAMETER	RISER PIPE DIAMETER	DOME GRATE DIAMETER	RISER CREST ELEVATION	EMERGENCY SPILLWAY		STORAGE VOLUME		
							ELEVATION	WIDTH	REQUIRED (CF)	PROVIDED (CF)	
1	1028.00	1033.00	12"	12"	12"	1030.00	1033.00	50'	2.88	29,014	29,903

**(STX) PCSMP BASIN BUILD NOTES**

ST1 Rip Rap Apron - See Detail Sheet C6  
100 year WSE = 1032.33



**E & A CONSULTING GROUP, INC.**  
Engineering • Planning • Environmental & Field Services

10909 Mill Valley Road, Suite 100 • Omaha, NE 68154  
Phone: 402.895.4700 • Fax: 402.895.3599  
www.eacg.com

E&A Job #: 2018.037.006  
Missouri State Certificate of Authority # E-2014008210

**EXTRA SPACE STORAGE - LEE'S SUMMIT**  
650 OLDHAM PARKWAY  
LEE'S SUMMIT, MO

**Hernly ASSOCIATES**

1100 Rhode Island  
Lawrence, Kansas 66044  
785 - 749 - 5806  
FAX 785 - 749 - 1515

DRAWINGS

Date: 9/18/2018  
Drawn by: DRH  
Checked by: DRH  
Revisions:

**C9**

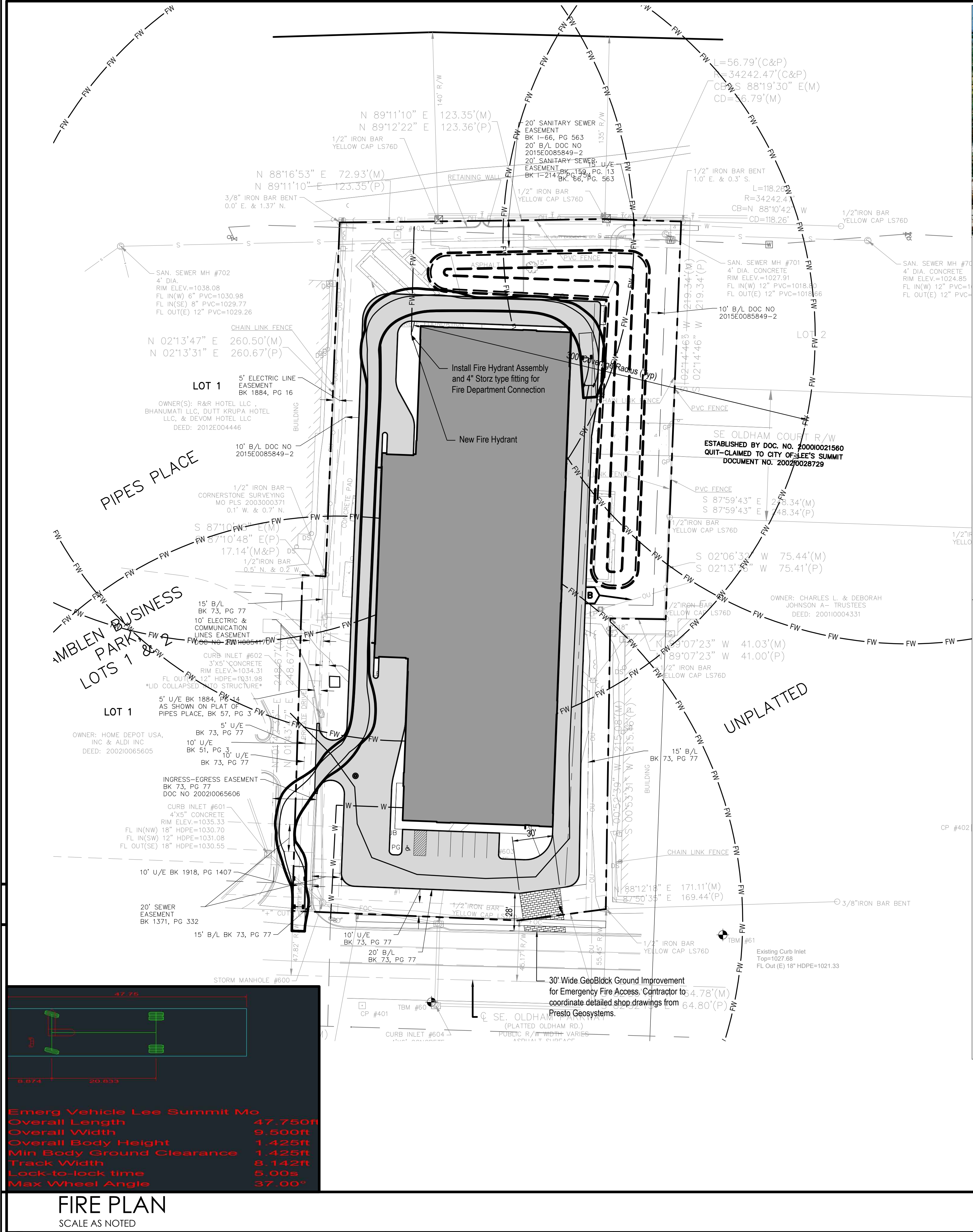

**Emerg Vehicle Lee Summit Mo**

Overall Length	47.750ft
Overall Width	9.500ft
Overall Body Height	1.425ft
Min Body Ground Clearance	1.425ft
Track Width	8.142ft
Lock-to-lock time	5.00s
Max Wheel Angle	37.00°

**FIRE PLAN**  
SCALE AS NOTED



**GEOBLOCK® & GEOBLOCK®5150 GRASS PAVERS FOR OCCASIONAL TRAFFIC**

The industry's strongest and most proven, high-performance turf protection systems address all vehicle loading and stormwater requirements. The GEOBLOCK® & GEOBLOCK®5150 systems' engineered base material supports loading up to H-20, is highly permeable to maximize stormwater percolation and, with topsoil infill, offers an optimal growing medium for vegetation.



LOAD DESCRIPTION	DESIGN GUIDELINE							
	Depth of Engineered BASE Recommendation: (Imperial)							
	GEOBLOCK®		GEOBLOCK®5150		GEOPAVE®		GEOPAVE®	
	VEGETATED SURFACES (Topsoil Infill)		VEGETATED SURFACES (Topsoil Infill)		AGGREGATE SURFACES (Aggregate Infill)		VEGETATED SURFACES (Topsoil/Aggregate Infill)	
TYPICAL MAXIMUM TIRE PRESSURE	Topsoil/Aggregate Base		Topsoil/Aggregate Base		Aggregate Base		Topsoil/Aggregate Base	
<b>GROSS VEHICLE LOADS</b>	CBR <sup>1,2</sup> 2-4	CBR <sup>1</sup> > 4	CBR <sup>1,2</sup> 2-4	CBR <sup>1</sup> > 4	CBR <sup>1,2</sup> 2-4	CBR <sup>1</sup> > 4	CBR <sup>1,2</sup> 2-4	CBR <sup>1</sup> > 4
<b>HEAVY FIRE TRUCK &amp; H-20 LOADING</b> Typical 110 psi 80,000 lb	14 in	10 in	6 in	4 in	6 in	6 in	Not Recommended	Not Recommended
Single axle loading of 32 kips; tandem axle loading of 48 kips.	Infrequent Passes	Infrequent Passes	Infrequent Passes	Normal Traffic	Normal Traffic	Normal Traffic	Not Recommended	Not Recommended
<b>LIGHT FIRE TRUCK &amp; H-15 LOADING</b> Typical 85 psi 60,000 lb	10 in	6-10 in	4 in	2 in	6 in	4 in	Not Recommended	Not Recommended
Single axle loading of 24 kips.	Infrequent Passes	Infrequent Passes	Infrequent Passes	Normal Traffic	Normal Traffic	Normal Traffic	Not Recommended	Not Recommended
<b>UTILITY &amp; DELIVERY TRUCK &amp; H-10 LOADING</b> Typical 60 psi 40,000 lb	6-10 in	4-8 in	2 in	2 in	4 in	2 in	4 in	2 in
Single axle loading of 16 kips.	Infrequent Passes	Infrequent Passes	Infrequent Passes	Normal Traffic	Normal Traffic	Normal Traffic	Infrequent Passes	Infrequent Passes
<b>CARS &amp; PICK-UP TRUCK ACCESS</b> Typical 45 psi 8,000 lb	4-8 in	2-4 in	None	None	2 in	None <sup>3</sup>	2 in	None <sup>3</sup>
Single axle loading of 4 kips.	Occasional Passes	Occasional Passes	Occasional Passes	Normal Traffic	Normal Traffic	Normal Traffic	Occasional Passes	Occasional Passes
<b>TRAIL USE: SURFACE STABILIZATION</b> <1,000 lb	2-4 in	0-2 in	None	None	None	None	None	None

Loading for ATVs, golf carts, campers, boats, equestrian, motorcycle, bicycle, pedestrian, wheelchairs.

<sup>1</sup> CBR is the abbreviation for California Bearing Ratio. Methods for determining CBR vary from more sophisticated laboratory methods to simple field identification methods that use hand manipulation of the soil. If other-than-CBR soil strength values exist, use available correlation charts to relate the value to CBR.

<sup>2</sup> For CBR < 2, contact Presto Products Company for recommendations.

<sup>3</sup> A minimum of 2 inches of aggregate base should be placed below the GeoPave units as a drainage layer and an infiltration storage area. Greater depth may be required depending upon design rainfall requirements and subbase permeability.

**ALL DESIGNS SHOULD BE CHECKED BY A CERTIFIED ENGINEER.** 1 Feb 2016 Presto Products Company [www.prestogeo.com](http://www.prestogeo.com) Copyright 2016

mo1call.com 1-800-DIG-RITE  
1-800-344-7483  
**Missouri811**  
know what's below.  
Call before you dig.  
Dial: 811

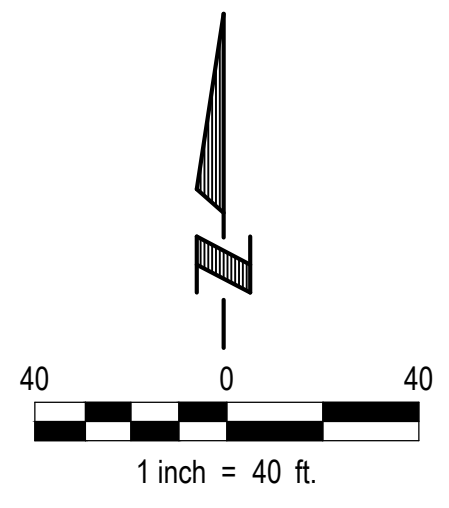

- FW Fire Coverage Radius
- GeoBlock Ground Improvement/ Emergency Fire Access
- Building Footprint(s)
- R Ridge Line
- Inverted Crown Line
- 100 Year WSE
- Dry Detention Basin Perimeter
- Property Line

STATE OF MISSOURI  
David R. Harnisch, Jr.  
Civil Engineer  
MOW PE-2015003013  
1-7-2015  
PROFESSIONAL ENGINEER

**EXTRA SPACE STORAGE - LEE'S SUMMIT**  
650 OLDHAM PARKWAY  
LEE'S SUMMIT, MO

**Hernly ASSOCIATES**

1100 Rhode Island  
Lawrence, Kansas  
66044  
785-749-5806  
FAX 785-749-1515

DRAWINGS

Date: 9/18/2016  
Drawn by: DRH  
Checked by: DRH  
Revisions:

**C10**



**E & A CONSULTING GROUP, INC.**  
Engineering • Planning • Environmental & Field Services

10909 Mill Valley Road, Suite 100 • Omaha, NE 68154  
Phone: 402.895.4700 • Fax: 402.895.3599  
www.eagc.com  
E&A Job #: 2018.037.006  
Missouri State Certificate of Authority # E-2014008210