

PLAN LEGEND:

- BOUNDARIES**
- EP — EXISTING PROPERTY LINE
 - P — PROPOSED PROPERTY LINE
 - FR — FUTURE PROPERTY LINE
 - — EXISTING LOT LINE
 - — PROPOSED LOT LINE
 - — FUTURE LOT LINE
 - ER/W — EXISTING RIGHT-OF-WAY
 - R/W — PROPOSED RIGHT-OF-WAY
 - FR/W — FUTURE RIGHT-OF-WAY
- CONTOURS**
- 100— EXISTING INDEX CONTOURS
 - 100— EXISTING INTERMEDIATE CONTOURS
 - 100— PROPOSED INDEX CONTOURS
 - 100— PROPOSED INTERMEDIATE CONTOURS

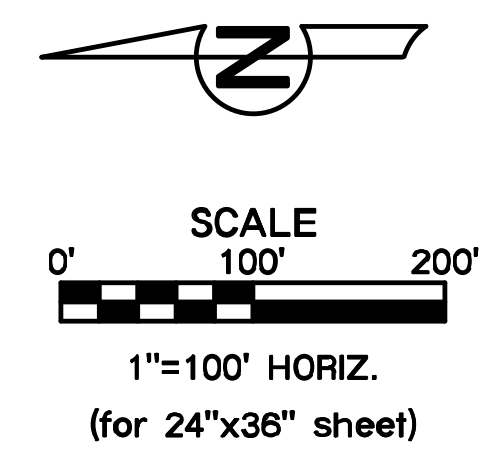

NO.: REVISIONS/APPROVALS:

09-16-2016	Submitted to CITY.
10-16-2016	Submitted to CITY.

Reviewed By: SOB
 Designed By: C/JH
 Drafted By: C/JH
 Lutfjen Project No.: 016-1889

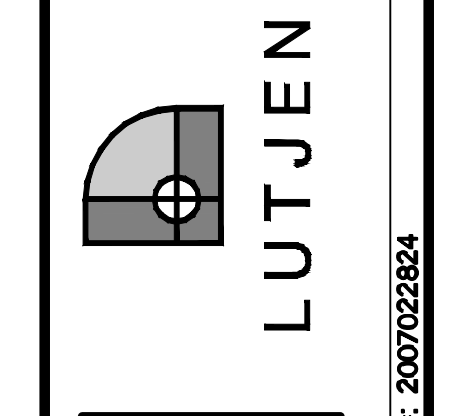

OLSSON ASSOCIATES
 1500 Redwood, # 200
 North Houston, TX, MO 64116
 TEL: 816.897.9200
 FAX: 816.897.1300
 www.olssonassociates.com
 MO State Certificate of Authority #: 2007028284

GRADING PLAN
ARBORWALK NORTH
LEE'S SUMMIT, JACKSON COUNTY,
MISSOURI

Sheet No.:
C004

Location: F:\2016\1501-2000\Lutfjen\Plans\Development\Plan\04 - GRI - 016-1889.dwg