

U-HAUL MOVING & STORAGE

LEE'S SUMMIT, MO

ISG PROJECT # 22-26154

LEGEND

EXISTING	
---	CITY LIMITS
---	SECTION LINE
---	QUARTER SECTION LINE
---	RIGHT OF WAY LINE
---	PROPERTY / LOTLINE
---	EASEMENT LINE
---	ACCESS CONTROL
---	WATER EDGE
---	WETLAND BOUNDARY
---	WETLAND / MARSH
---	FENCE LINE
---	CULVERT
---	STORM SEWER
---	SANITARY SEWER
---	SANITARY SEWER FORCEMAIN
---	WATER
---	GAS
---	OVERHEAD ELECTRIC
---	UNDERGROUND ELECTRIC
---	UNDERGROUND TELEPHONE
---	UNDERGROUND TV
---	OVERHEAD UTILITY
---	UNDERGROUND UTILITY
---	UNDERGROUND FIBER OPTIC
---	CONTOUR (MAJOR)
---	CONTOUR (MINOR)
---	DECIDUOUS TREE
---	CONIFEROUS TREE
---	TREE LINE
---	MANHOLE/STRUCTURE
---	CATCH BASIN
---	HYDRANT
---	VALVE
---	CURB STOP
---	POWER POLE
---	UTILITY PEDESTAL / CABINET

PROPOSED	
---	LOT LINE
---	RIGHT OF WAY
---	EASEMENT
---	CULVERT
---	STORM SEWER
---	STORM SEWER (PIPE WIDTH)
---	SANITARY SEWER
---	SANITARY SEWER (PIPE WIDTH)
---	WATER
---	GAS
---	OVERHEAD ELECTRIC
---	UNDERGROUND ELECTRIC
---	UNDERGROUND TV
---	CONTOUR
---	MANHOLE (STORM, SANITARY)
---	CATCH BASIN
---	HYDRANT
---	VALVE



LOCATION MAP
SCALE IN FEET
0 500 1000

ABBREVIATIONS:

AC	ACRE	CJ	CONTROL JOINT	EOF	EMERGENCY OVERFLOW	GL	GUTTER LINE	IPS	IRON PIPE SIZE	NWL	NORMAL WATER LEVEL	RCP	REINFORCED CONCRETE PIPE	THRU	THROUGH
ADA	AMERICANS WITH DISABILITIES ACT	CL	CENTERLINE	EQ	EQUAL	GPM	GALLONS PER MINUTE	J-B	JUNCTION BOX	OC	ON CENTER	RD	ROOF DRAIN	TNFH	TOP NUT OF FIRE HYDRANT
ADD	ADDENDUM	CMP	CORRUGATED METAL PIPE	EX	EXISTING	GV	GATE VALVE	JT	JOINT	OCEW	ON CENTER EACH WAY	REBAR	REINFORCING BAR	TRANS	TRANSFORMER
AF	ABOVE FINISHED FLOOR	CO	CLEANOUT	FDC	FIRE DEPARTMENT CONNECTION	HDPE	HIGH DENSITY POLYETHYLENE	LF	LINEAR FEET	OH	OVERHEAD	REM	REMOVE	TV	TELEVISION
AGG	AGGREGATE	CONC	CONCRETE	FDN	FOUNDATION	HD	HEAVY DUTY	LIN	LINEAR	OHD	OVERHEAD DOOR	ROW	RIGHT OF WAY	T/W	TOP OF WALL
APPROX	APPROXIMATE	CONST	CONSTRUCTION	FES	FLARED END SECTION	HH	HANDHOLE	LPS	LOW PRESSURE STEAM	OZ	OUNCE	R/W	RIGHT OF WAY	TYP	TYPICAL
ARCH	ARCHITECT, ARCHITECTURAL	CONT	CONTINUOUS	FFE	FINISHED FLOOR ELEVATION	HORIZ	HORIZONTAL	LS	LUMP SUM	PED	PEDESTAL, PEDESTRIAN	SAN	SANITARY	UT	UTILITY, UNDERGROUND
BFE	BASEMENT FLOOR ELEVATION	CY	CUBIC YARD	FPM	FEET PER MINUTE	HR	HOUR	LSO	LOWEST STRUCTURAL OPENING	PERF	PERFORATED	SCH	SCHEDULE	VCP	VENTRILATED CLAY PIPE
BIT	BITUMINOUS	C&G	CURB AND GUTTER	FPS	FEET PER SECOND	HWL	HIGH WATER LEVEL	MAX	MAXIMUM	PL	PROPERTY LINE	SF	SQUARE FOOT	W/O	WITHOUT
CAD	COMPUTER-AIDED DESIGN	DEMO	DEMOLITION	FT	FOOT, FEET	HWY	HIGHWAY	MB	MAIL BOX	PP	POLYPROPYLENE	SPEC	SPECIFICATION	Y	YARD
CB	CATCH BASIN	DIA	DIAMETER	FTG	FOOTING	HYD	HYDRANT	MECH	MECHANICAL	PSI	POUNDS PER SQUARE INCH	SQ	SQUARE	YD	YARD
CFS	CUBIC FEET PER SECOND	DIM	DIMENSION	GA	GALVE	I	INVERT	NH	MANHOLE	PVC	POLYVINYL CHLORIDE	STA	STATION	YR	YEAR
CF	CURB FOOT	DS	DOWNSPOUT	GAL	GALLON	ID	INSIDE DIAMETER	MIN	MINIMUM	PVMT	PAVEMENT	SY	SQUARE YARD		
CI	CAST IRON	EA	EACH	GALV	GALVANIZED	IN	INCH	MISC	MISCELLANEOUS	QTY	QUANTITY	T/C	TOP OF CURB		
CIP	CAST IRON PIPE	ELEC	ELECTRICAL	GC	GENERAL CONTRACTOR	INV	INVERT	NO	NUMBER	R	RIM	TEL	TELEPHONE		
CIPC	CAST IN PLACE CONCRETE	ELEV	ELEVATION	GFE	GARAGE FLOOR ELEVATION	IP	IRON PIPE	NTS	NOT TO SCALE	RAD	RADIUS	TEMP	TEMPORARY		

PROJECT INDEX:

OWNER:
AMERCO REAL ESTATE COMPANY
2727 NORTH CENTRAL AVE
PHOENIX, AZ 85004
PH: 602-263-6502

PROJECT ADDRESS / LOCATION:
1150 SE BLUE PKWY
LEE'S SUMMIT, MO 64063

MANAGING OFFICE:
DES MOINES OFFICE
217 EAST 2nd STREET
SUITE 110
DES MOINES, IA 50309
PHONE: 515.243.9143

PROJECT MANAGER: RYAN ANDERSON
EMAIL: RYAN.ANDERSON@ISGINC.COM

SPECIFICATIONS REFERENCE

ALL CONSTRUCTION SHALL COMPLY WITH THE CITY OF LEE'S SUMMIT REQUIREMENTS AND MODOT STANDARD SPECIFICATIONS FOR CONSTRUCTION, 2020 EDITION, AND THE STANDARD SPECIFICATIONS FOR SANITARY SEWER, STORM DRAIN AND WATERMAIN AS PROPOSED BY THE CITY OF LEE'S SUMMIT UNLESS DIRECTED OTHERWISE.

PROJECT DATUM

HORIZONTAL COORDINATES HAVE BEEN REFERENCED TO THE NORTH AMERICAN DATUM OF 1983 (NAD83), ON THE MISSOURI STATE PLANE WEST ZONE COORDINATE SYSTEM, IN U.S. SURVEY FEET. ELEVATIONS HAVE BEEN REFERENCED TO THE NORTH AMERICAN VERTICAL DATUM OF 1988 (NAVD 88). RTK GPS METHODS WERE USED TO ESTABLISH HORIZONTAL AND VERTICAL COORDINATES FOR THIS PROJECT.

B.M. ELEVATION=1046.26
KC METRO ALUMINUM GRS DISK SET IN CONCRETE 3" BELOW THE PAVEMENT ON SHOULDER OF SE RANSON ROAD
B.M. ELEVATION=979.17
TOP OF CATCH BASIN LOCATED ON THE SOUTH SIDE OF SE 8TH STREET NEAR THE NORTHEAST PROPERTY CORNER

THIS PROJECT'S TOPOGRAPHIC SURVEY CONSISTS OF DATA COLLECTED IN JANUARY 2022 BY THE DESIGN GROUP, INC.

SHEET INDEX

C0-10	COVER SHEET
C2-10	EXISTING SITE & REMOVAL PLAN
C3-10	SITE PLAN
C4-10	GRADING PLAN
C5-10	UTILITY PLAN
C6-10	SITE DETAILS
C7-10	PLANTING AND RESTORATION PLAN
C7-20	LANDSCAPE DETAILS
E1-10	PHOTOMETRIC PLAN
E1-11	PHOTOMETRIC DETAILS

PROJECT GENERAL NOTES

- ALL WORK SHALL CONFORM TO THE CONTRACT DOCUMENTS, WHICH INCLUDE, BUT ARE NOT LIMITED TO, THE OWNER - CONTRACTOR AGREEMENT, THE PROJECT MANUAL (WHICH INCLUDES GENERAL SUPPLEMENTARY CONDITIONS AND SPECIFICATIONS), DRAWINGS OF ALL DISCIPLINES AND ALL ADDENDA, MODIFICATIONS AND CLARIFICATIONS ISSUED BY THE ARCHITECT/ENGINEER.
- CONTRACT DOCUMENTS SHALL BE ISSUED TO ALL SUBCONTRACTORS BY THE GENERAL CONTRACTOR IN COMPLETE SETS IN ORDER TO ACHIEVE THE FULL EXTENT AND COMPLETE COORDINATION OF ALL WORK.
- WRITTEN DIMENSIONS TAKE PRECEDENCE OVER SCALED DIMENSIONS. NOTIFY ARCHITECT/ENGINEER OF ANY DISCREPANCIES OR CONDITIONS REQUIRING INFORMATION OR CLARIFICATION BEFORE PROCEEDING WITH THE WORK.
- FIELD VERIFY ALL EXISTING CONDITIONS AND DIMENSIONS. NOTIFY ARCHITECT/ENGINEER OF ANY DISCREPANCIES OR CONDITIONS REQUIRING INFORMATION OR CLARIFICATION BEFORE PROCEEDING WITH THE WORK.
- DETAILS SHOWN ARE INTENDED TO BE INDICATIVE OF THE PROFILES AND TYPE OF DETAILING REQUIRED THROUGHOUT THE WORK. DETAILS NOT SHOWN ARE SIMILAR IN CHARACTER TO DETAILS SHOWN, WHERE SPECIFIC DIMENSIONS, DETAILS OR DESIGN INTENT CANNOT BE DETERMINED, NOTIFY ARCHITECT/ENGINEER BEFORE PROCEEDING WITH THE WORK.
- ALL MANUFACTURED ARTICLES, MATERIALS AND EQUIPMENT SHALL BE APPLIED, INSTALLED, CONNECTED, ERECTED, CLEANED AND CONDITIONED ACCORDING TO MANUFACTURERS' INSTRUCTIONS. IN CASE OF DISCREPANCIES BETWEEN MANUFACTURERS' INSTRUCTIONS AND THE CONTRACT DOCUMENTS, NOTIFY ARCHITECT/ENGINEER BEFORE PROCEEDING WITH THE WORK.
- ALL DISSIMILAR METALS SHALL BE EFFECTIVELY ISOLATED FROM EACH OTHER TO AVOID GALVANIC CORROSION.
- THE LOCATION AND TYPE OF ALL INPLACE UTILITIES SHOWN ON THE PLANS ARE FOR GENERAL INFORMATION ONLY AND ARE ACCURATE AND COMPLETE TO THE BEST OF THE KNOWLEDGE OF I & S GROUP, INC. (ISG). NO WARRANTY OR GUARANTEE IS IMPLIED. THE CONTRACTOR SHALL VERIFY THE SIZES, LOCATIONS AND ELEVATIONS OF ALL INPLACE UTILITIES PRIOR TO CONSTRUCTION. CONTRACTOR SHALL IMMEDIATELY NOTIFY ENGINEER OF ANY DISCREPANCIES OR VARIATIONS FROM PLAN.
- THE CONTRACTOR IS TO CONTACT "MISSOURI ONE CALL SYSTEM" FOR UTILITY LOCATIONS, MINIMUM 2 BUSINESS DAYS PRIOR TO ANY EXCAVATION / CONSTRUCTION (1-800-344-7483).

SHEET NOTES:

REVISIONS:

#	DATE	INITIALS	NOTES
1	05/02/2022	AJR	REVISED SET PER CITY COMMENTS
2	08/14/2022	ARA	REVISED SET PER CITY COMMENTS
3	09/27/2022	ARA	REVISED SET PER CITY COMMENTS

PROFESSIONAL SEAL:



THIS DOCUMENT IS THE PROPERTY OF I & S GROUP, INC. AND MAY NOT BE USED, COPIED OR DUPLICATED WITHOUT PRIOR WRITTEN CONSENT.

DES MOINES OFFICE
217 EAST 2nd STREET
SUITE 110
DES MOINES, IA 50309
PHONE: 515.243.9143
PROJECT MANAGER: RYAN ANDERSON
EMAIL: RYAN.ANDERSON@ISGINC.COM

THESE PLANS HAVE BEEN PREPARED BY
AMERCO
REAL ESTATE COMPANY

CONSTRUCTION DEPARTMENT
2727 NORTH CENTRAL AVENUE
PHOENIX, ARIZONA 85004
PH: (602) 263-6502

SITE ADDRESS:
U-Haul Moving & Storage
710 SE BLUE PARKWAY
LEE'S SUMMIT, MO

SHEET CONTENTS:

COVER SHEET

DRAWN: AJR

CHECKED: AA

DATE: 04/22/22

26154 CD COVER

#	DATE	INITIALS	NOTES
1	05/01/2022	AJR	REVISED SET PER CITY COMMENTS
2	06/14/2022	AA	REVISED SET PER CITY COMMENTS
3	06/27/2022	AA	REVISED SET PER CITY COMMENTS



THIS DOCUMENT IS THE PROPERTY OF I & S GROUP, INC. AND MAY NOT BE USED, COPIED OR DUPLICATED WITHOUT PRIOR WRITTEN CONSENT.

DES MOINES OFFICE
217 EAST 2nd STREET
SUITE 110
DES MOINES, IA 50309
PHONE: 515.243.9143
PROJECT MANAGER: RYAN ANDERSON
EMAIL: RYAN.ANDERSON@ISG.COM

THESE PLANS HAVE BEEN PREPARED BY
AMERCO
REAL ESTATE COMPANY

CONSTRUCTION DEPARTMENT
2721 NORTH CENTRAL AVENUE
PHOENIX, ARIZONA 85004
PH: (602) 263-6502

SITE ADDRESS:
U-Haul Moving & Storage
710 SE BLUE PARKWAY
LEE'S SUMMIT, MO

SHEET CONTENTS:
EXISTING SITE & REMOVAL PLAN

DRAWN: AJR
CHECKED: AA
DATE: 04/22/22

PRELIMINARY NOT FOR CONSTRUCTION

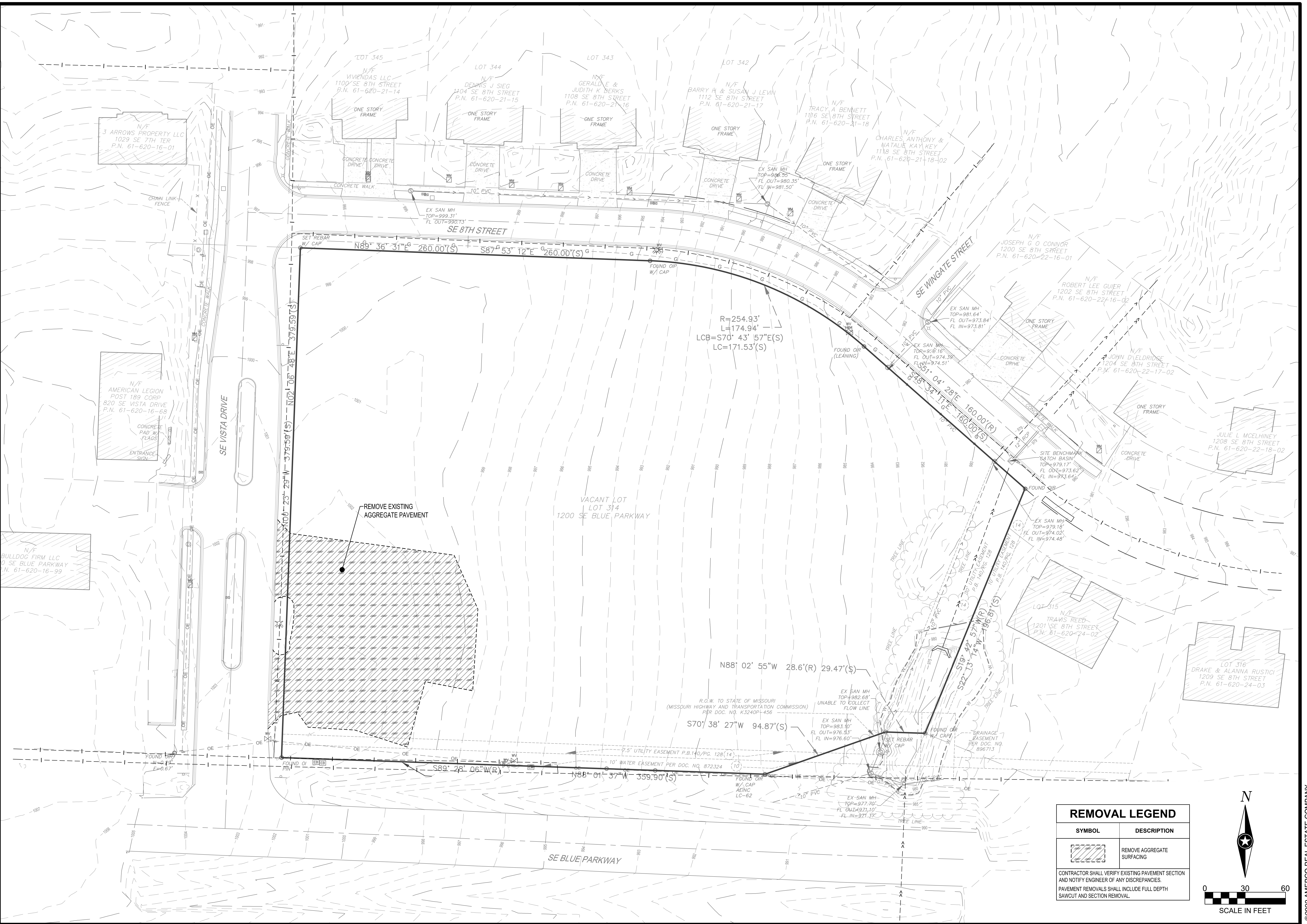

REMOVAL LEGEND	
SYMBOL	DESCRIPTION
	REMOVE AGGREGATE SURFACING

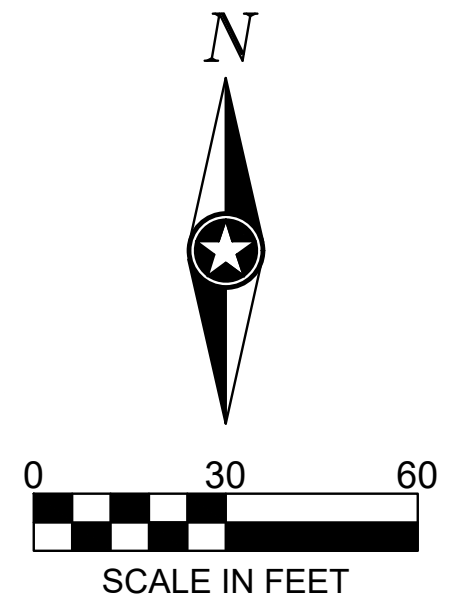

SITE SUMMARY	
ZONING:	CP-2
EXISTING LAND USE:	VACANT
PROPOSED LAND USE:	SELF-STORAGE
ADJACENT LAND USE AND ZONING:	NORTH / EAST: RESIDENTIAL (RP-2) SOUTH: HIGHWAY / COMMERCIAL (CP-2) WEST: COMMERCIAL (CP-2)
SITE/LOT AREA:	179,142 SQ. FT / 4.11 AC.
IMPERVIOUS AREA:	119,946 SQ. FT / 2.75 AC. (66.9%)
GREENSPACE:	59,196 SQ. FT / 1.36 AC. (33.1%)
PARKING AREA:	72,188 SQ. FT
LANDSCAPE ISLANDS IN PARKING AREAS:	3,772 SQ. FT (5.16%)
OIL OR GAS WELLS:	PER MDNR, THERE ARE NO OIL OR GAS WELLS LOCATED ON THIS PROPERTY.
WATERSHED:	LANGSFORD
FEMA FLOODPLAIN:	PER FEMA FLOODPLAIN MAP 04386 FOR JACKSON COUNTY MISSOURI THE SITE IS LOCATED WITHIN ZONE X, AREAS WITH LESS THAN 0.2% ANNUAL FLOOD CHANCE
LEGAL DESCRIPTION:	LOT 314, VISTA DEL VERDE 11TH PLAT, A SUBDIVISION IN LEE'S SUMMIT, JACKSON COUNTY, MISSOURI, EXCEPT THAT PART CONVEYED TO MISSOURI HIGHWAY AND TRANSPORTATION COMMISSION BY WARRENTY DEED RECORDED AS DOCUMENT NO 89K38698 IN BOOK K3240, PAGE 456.

PARKING REQUIREMENTS				
BUILDING	CALCULATION	STALLS REQUIRED	STALLS PROVIDED	
SELF-STORAGE	2 + 1/EMPLOYEE	3		
U-BOX WAREHOUSE	2 + 1/EMPLOYEE	3		
RETAIL (2,000 SF)	5/1,000 SF	10		
TOTAL:		16	17	

SETBACKS		
	PARKING	BUILDING
FRONT YARD	20'	15'
SIDE YARD	20'	10'
REAR YARD	20'	20'

BUILDING INFO	
SELF STORAGE BUILDING	
GROSS FLOOR AREA:	88,404 SF
BUILDING HEIGHT:	40'
FLOORS:	3
FLOOR AREA RATIO:	48 %
U-BOX BUILDING	
GROSS FLOOR AREA:	10,559 SF
BUILDING HEIGHT:	40'
FLOORS:	1
FLOOR AREA RATIO:	6 %
TOTALS	
TOTAL FLOOR AREA:	98,963 SF
FLOOR AREA RATIO:	55 %

PAVEMENT LEGEND	
SYMBOL	DESCRIPTION
	ASPHALT PAVEMENT (SEE DETAIL)
	CONCRETE PAVEMENT
	HEAVY DUTY CONCRETE PAVEMENT
	STRAIGHT BACK DRY CURB & GUTTER (TYPE CG-1 DRY)

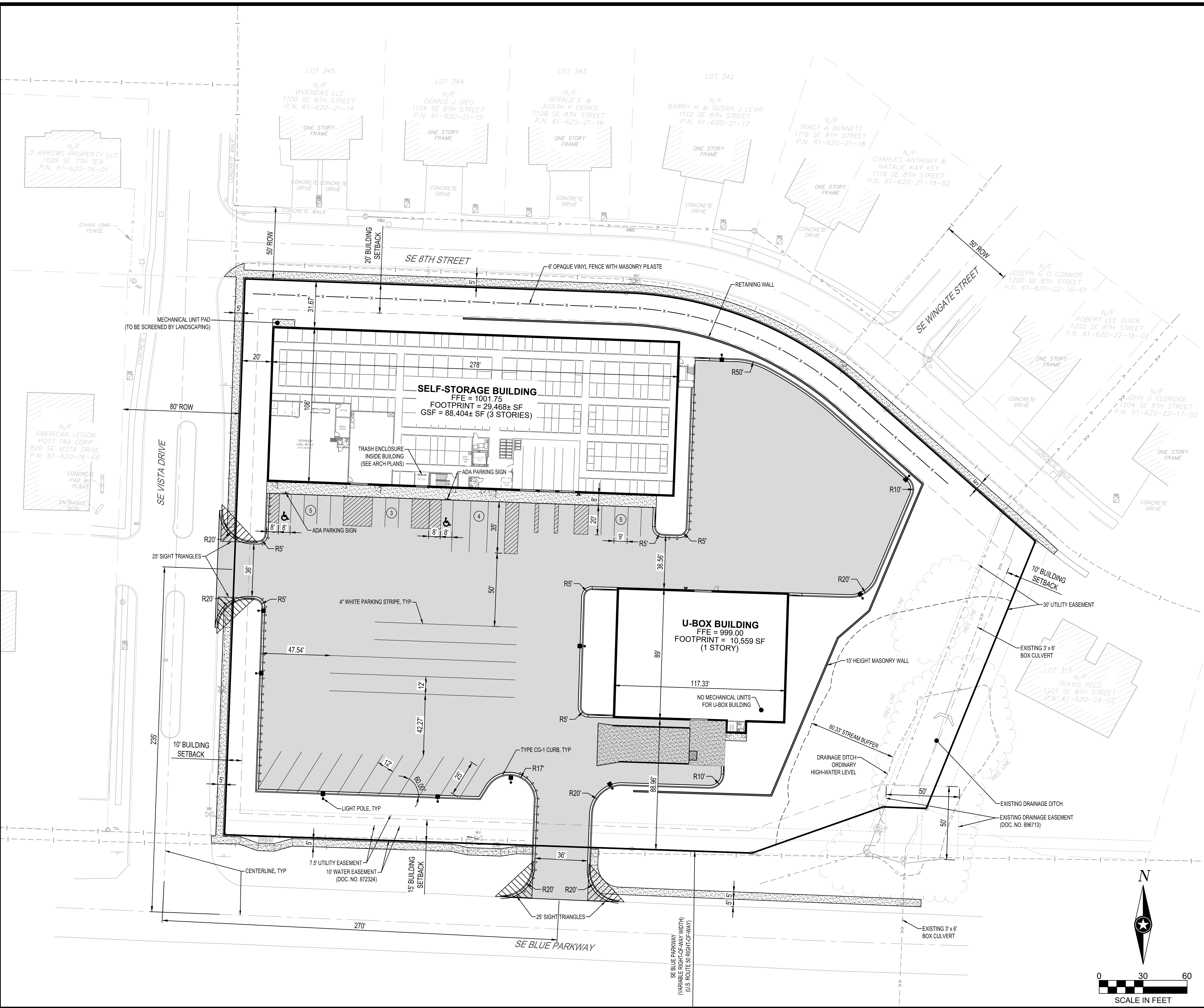
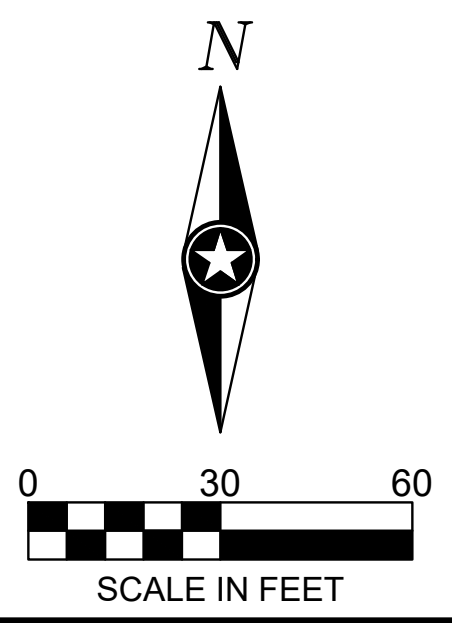
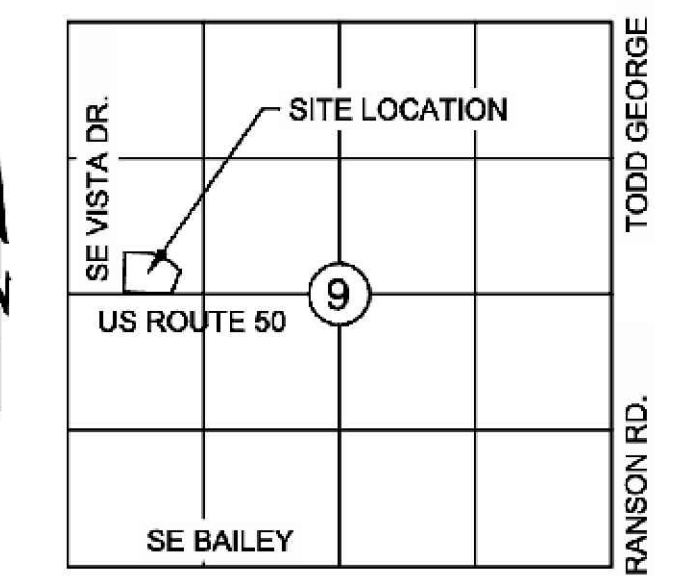

REVISIONS:				
#	DATE	INITIALS	NOTES	
1	05/02/2022	AJR	REVISED SET PER CITY COMMENTS	
2	08/14/2022	AA	REVISED SET PER CITY COMMENTS	
3	09/27/2022	AA	REVISED SET PER CITY COMMENTS	

PROFESSIONAL SEAL:



THIS DOCUMENT IS THE PROPERTY OF I & S GROUP, INC. AND MAY NOT BE USED, COPIED OR DUPLICATED WITHOUT PRIOR WRITTEN CONSENT.

DES MOINES OFFICE
217 EAST 2nd STREET
SUITE 110
DES MOINES, IA 50309
PHONE: 515.243.9143
PROJECT MANAGER: RYAN ANDERSON
EMAIL: RYAN.ANDERSON@ISG.COM

THESE PLANS HAVE BEEN PREPARED BY
AMERCO
REAL ESTATE COMPANY

CONSTRUCTION DEPARTMENT
2721 NORTH CENTRAL AVENUE
PHOENIX, ARIZONA 85004
PH: (602) 263-4502

SITE ADDRESS:
U-Haul Moving & Storage
710 SE BLUE PARKWAY
LEE'S SUMMIT, MO

SHEET CONTENTS:
SITE PLAN

DRAWN:	AJR	C3-10
CHECKED:	AA	
DATE:	04/22/22	

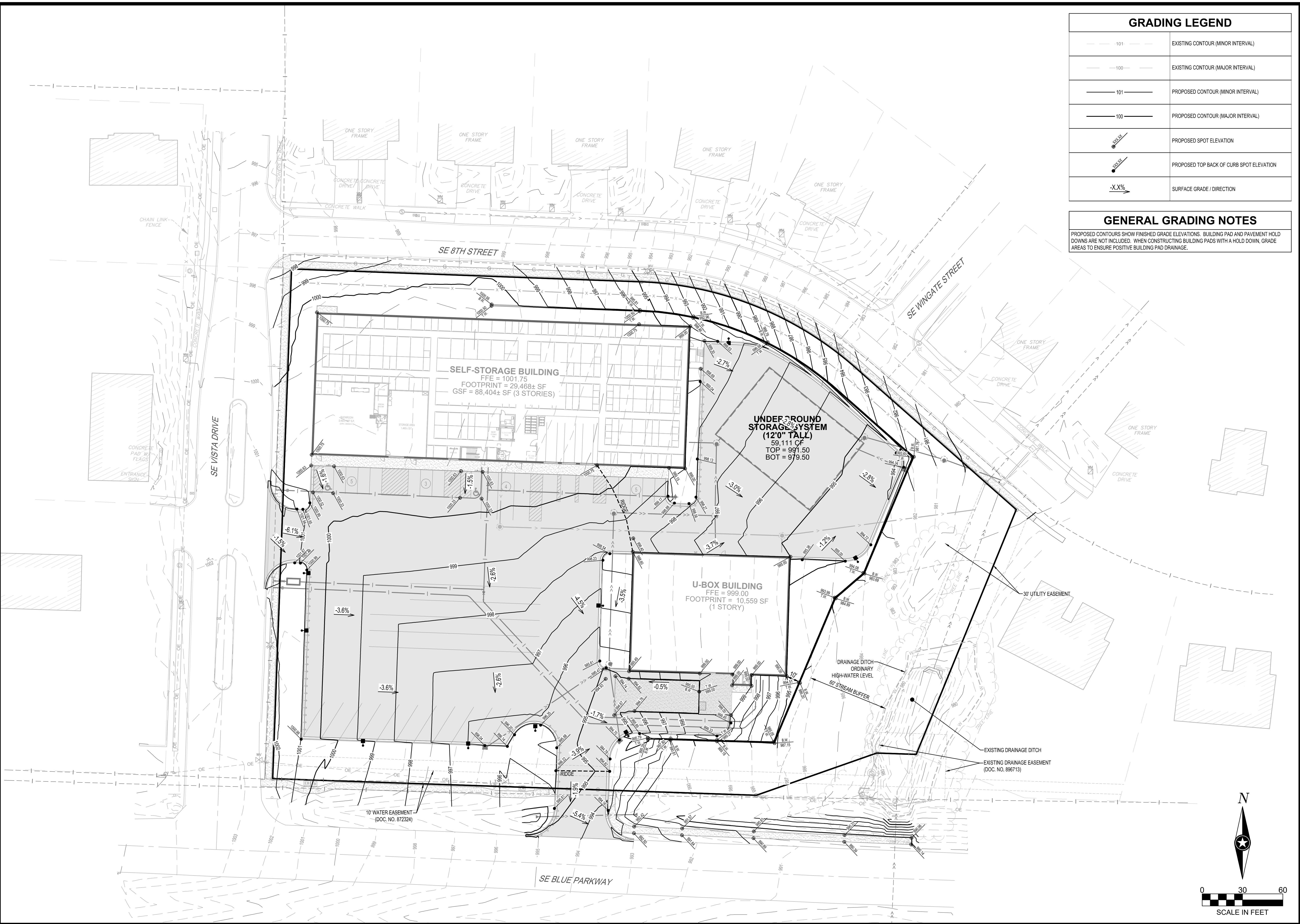

GRADING LEGEND	
--- 101 ---	EXISTING CONTOUR (MINOR INTERVAL)
--- 100 ---	EXISTING CONTOUR (MAJOR INTERVAL)
— 101 —	PROPOSED CONTOUR (MINOR INTERVAL)
— 100 —	PROPOSED CONTOUR (MAJOR INTERVAL)
● 991.5	PROPOSED SPOT ELEVATION
● 991.5	PROPOSED TOP BACK OF CURB SPOT ELEVATION
-X.X%	SURFACE GRADE / DIRECTION

GENERAL GRADING NOTES
 PROPOSED CONTOURS SHOW FINISHED GRADE ELEVATIONS. BUILDING PAD AND PAVEMENT HOLD DOWNS ARE NOT INCLUDED. WHEN CONSTRUCTING BUILDING PADS WITH A HOLD DOWN, GRADE AREAS TO ENSURE POSITIVE BUILDING PAD DRAINAGE.

SHEET NOTES:

REVISIONS:			
#	DATE	INITIALS	NOTES
1	05/03/2022	AJR	REVISED SET PER CITY COMMENTS
2	06/14/2022	AA	REVISED SET PER CITY COMMENTS
3	09/27/2022	AA	REVISED SET PER CITY COMMENTS

PROFESSIONAL SEAL:



THIS DOCUMENT IS THE PROPERTY OF I & S GROUP, INC. AND MAY NOT BE USED, COPIED OR DUPLICATED WITHOUT PRIOR WRITTEN CONSENT.

DES MOINES OFFICE
 217 EAST 2nd STREET
 SUITE 110
 DES MOINES, IA 50309
 PHONE: 515.243.9143
 PROJECT MANAGER: RYAN ANDERSON
 EMAIL: RYAN.ANDERSON@ISG.COM

THESE PLANS HAVE BEEN PREPARED BY
AMERCO
 REAL ESTATE COMPANY

CONSTRUCTION DEPARTMENT
 2727 NORTH CENTRAL AVENUE
 PHOENIX, ARIZONA 85004
 PH: (602) 263-6502

SITE ADDRESS:
 U-Haul Moving & Storage
 710 SE BLUE PARKWAY
 LEE'S SUMMIT, MO

SHEET CONTENTS:
GRADING PLAN

DRAWN:	AJR	C4-10
CHECKED:	AA	
DATE:	04/22/22	

©2022 AMERCO REAL ESTATE COMPANY 26154 C4 GRADE

PRELIMINARY NOT FOR CONSTRUCTION

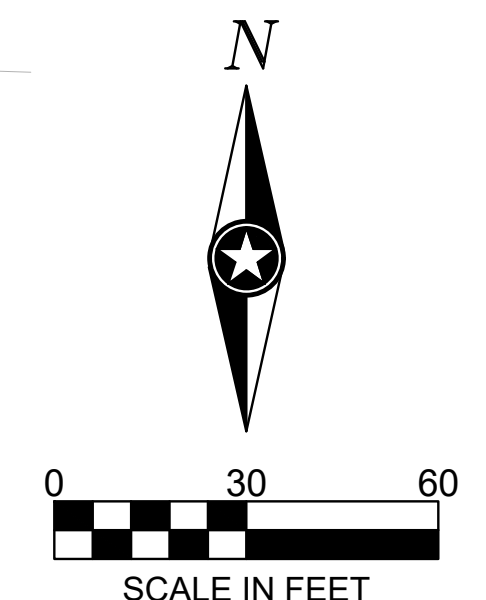

UTILITY LEGEND		
EXISTING		PROPOSED
-->>---	STORM DRAIN	--->>---
->---	SANITARY SEWER	--->---
- >---	SANITARY SEWER FORCEMAIN	--- >---
- ---	WATER MAIN	--- ---
-G---	GAS	---G---
-OE---	OVERHEAD ELECTRIC	---OE---
-UE---	UNDERGROUND ELECTRIC	---UE---
-UT---	UNDERGROUND TELEPHONE	---UT---
-UTV---	UNDERGROUND TV	---UTV---
-OHL---	OVERHEAD UTILITY	---OHL---
-UTL---	UNDERGROUND UTILITY	---UTL---
-FBO---	FIBER OPTIC	---FBO---

NOTE:
CONTRACTOR SHALL FIELD VERIFY THE LOCATIONS OF ALL EXISTING UTILITIES.

REVISIONS:

#	DATE	INITIALS	NOTES
1	05/03/2022	AJR	REVISED SET PER CITY COMMENTS
2	08/14/2022	AA	REVISED SET PER CITY COMMENTS
3	09/27/2022	AA	REVISED SET PER CITY COMMENTS

PROFESSIONAL SEAL:



THIS DOCUMENT IS THE PROPERTY OF I & S GROUP, INC. AND MAY NOT BE USED, COPIED OR DUPLICATED WITHOUT PRIOR WRITTEN CONSENT.

DES MOINES OFFICE
217 EAST 2nd STREET
SUITE 110
DES MOINES, IA 50309
PHONE: 515.243.9143
PROJECT MANAGER: RYAN ANDERSON
EMAIL: RYAN.ANDERSON@ISG.COM

THESE PLANS HAVE BEEN PREPARED BY
AMERCO
REAL ESTATE COMPANY

CONSTRUCTION DEPARTMENT
2721 NORTH CENTRAL AVENUE
PHOENIX, ARIZONA 85004
PH: (602) 263-6502

SITE ADDRESS:
U-Haul Moving & Storage
710 SE BLUE PARKWAY
LEE'S SUMMIT, MO

SHEET CONTENTS:

UTILITY PLAN

DRAWN: AJR
CHECKED: AA
DATE: 04/22/22
C5-10

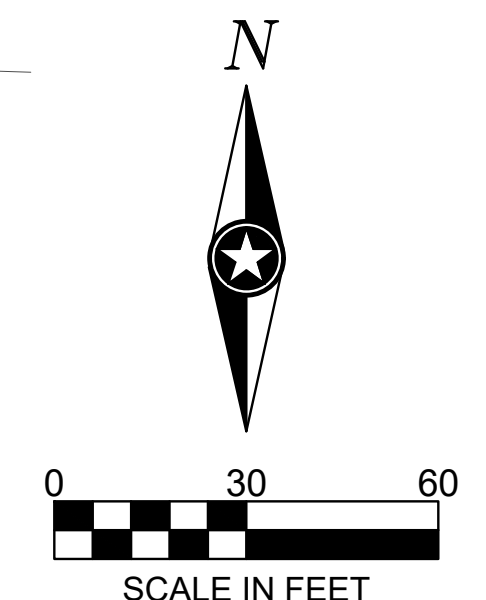
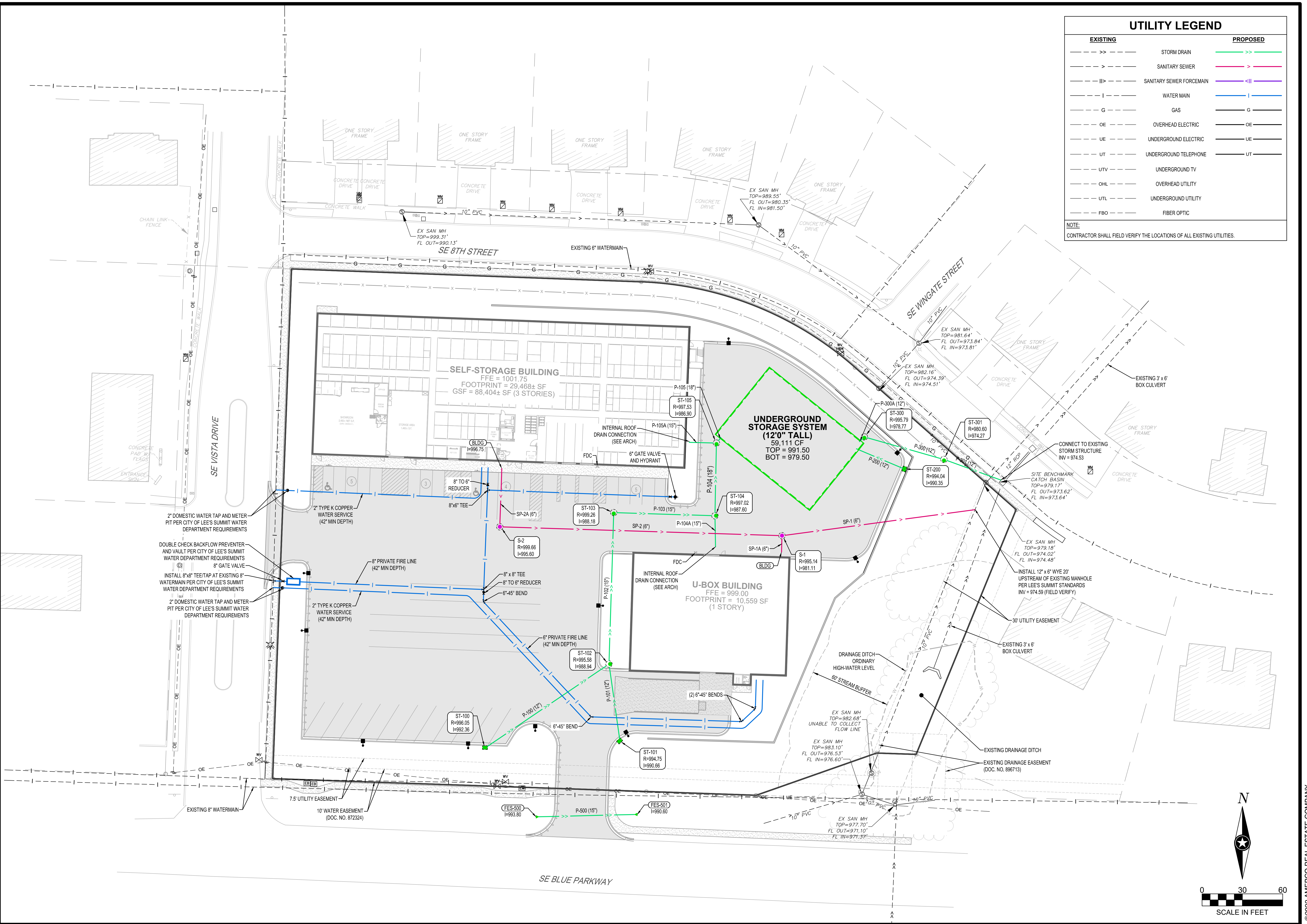

PRELIMINARY NOT FOR CONSTRUCTION

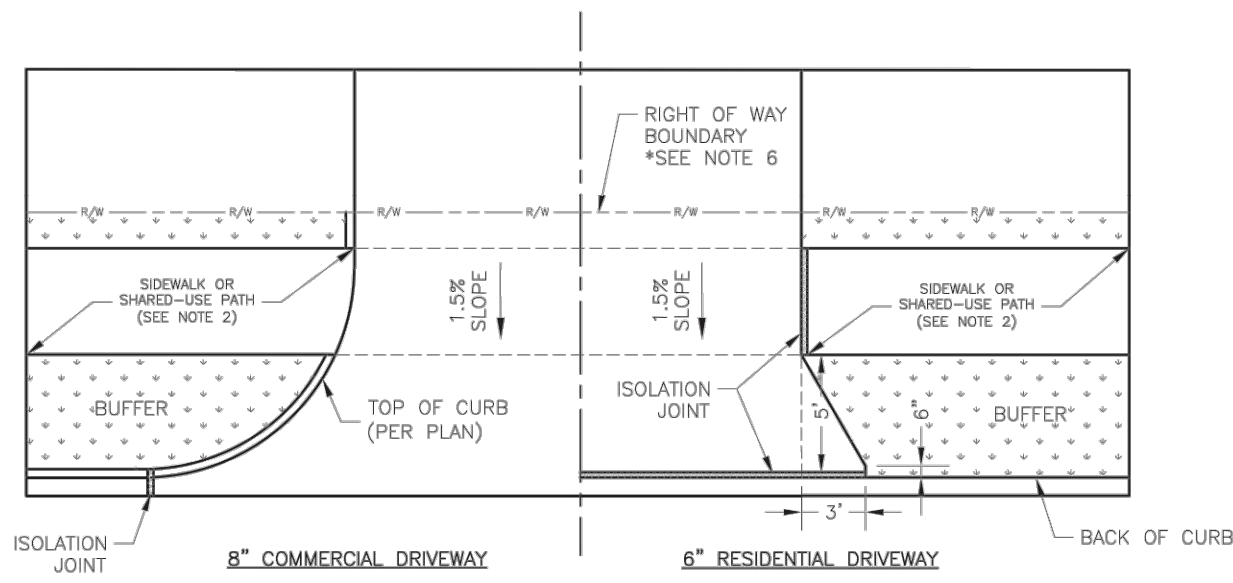

DRIVEWAY WITH BUFFER
NOT TO SCALE

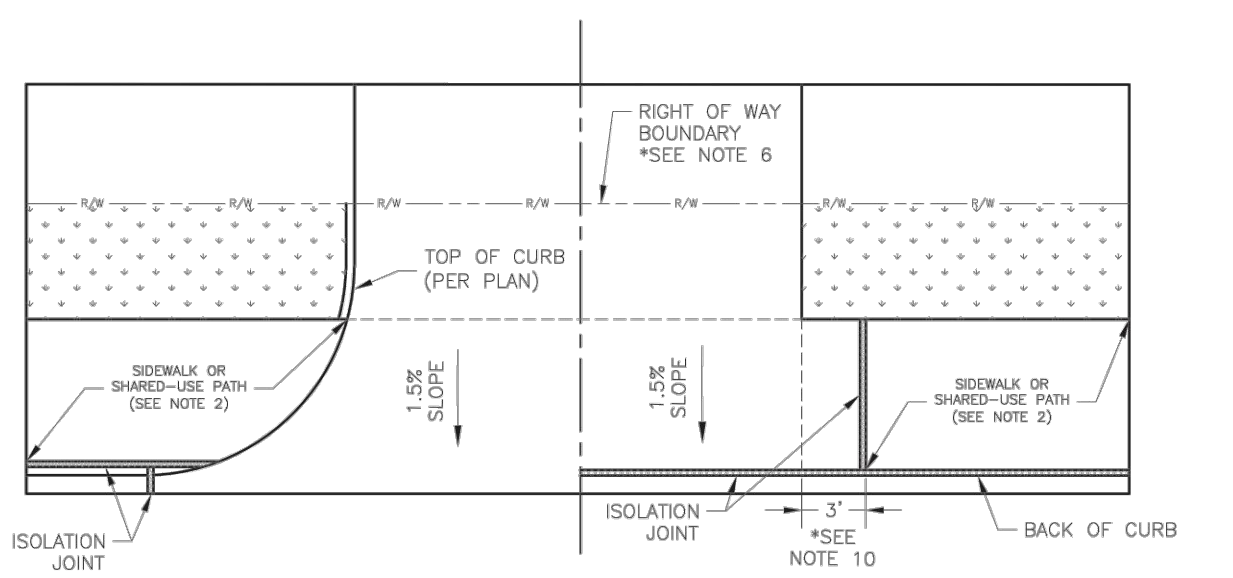

DRIVEWAY WITHOUT BUFFER
NOT TO SCALE

- GENERAL NOTES:**
- SUBGRADE SHALL BE STABLE, COMPACTED EARTH AND SHALL BE OVERLAYED WITH 4" COMPACTED DENSE GRADED AGGREGATE BASE.
 - ALL DRIVE APPROACHES SHALL MEET CURRENT PUBLIC RIGHT OF WAY ACCESSIBILITY GUIDELINES (PROWAG) FOR SLOPE REQUIREMENTS WHEN SIDEWALK IS REQUIRED (SEE ADA RAMP RETROFIT DETAIL GEN-3B, SIDEWALK/SHARED USE PATH RAMP AT DRIVEWAY DETAIL).
 - JOINT AT BACK OF CURB LINE SHALL BE AN ISOLATION JOINT FOR RESIDENTIAL DRIVEWAYS.
 - KCMBB 4K CONCRETE MIX IS REQUIRED FOR ALL CURBS.
 - COMMERCIAL DRIVEWAYS, IN THE PUBLIC RIGHT OF WAY, SHALL BE KCMBB 4K CONCRETE MIX.
 - RESIDENTIAL DRIVEWAYS, IN THE PUBLIC RIGHT OF WAY, KCMBB 4K CONCRETE MIX IS RECOMMENDED. OTHER CONCRETE MIXES NEED TO BE APPROVED BY CITY INSPECTOR.
 - A JOINT MUST BE INSTALLED AT THE RIGHT OF WAY BOUNDARY FOR PROPERTY DELINEATION.
 - WHITE CURING COMPOUND MUST BE APPLIED UNIFORMLY TO THE CONCRETE SURFACE IMMEDIATELY AFTER FINAL FINISHING.
 - 3/4" FROM TOP OF CURB TO FLOWLINE AT DRIVEWAY (TYPE CG-1 CURB ONLY). MUST MAINTAIN ORIGINAL FLOWLINE OF CURB.
 - SIDEWALK ADJOINING CURB SHALL BE 6" THICK, EXTENDING 3" FROM THE DRIVEWAY.
 - THE MAXIMUM WIDTH OF A RESIDENTIAL DRIVEWAY IS 36 FEET WITHIN THE RIGHT OF WAY.

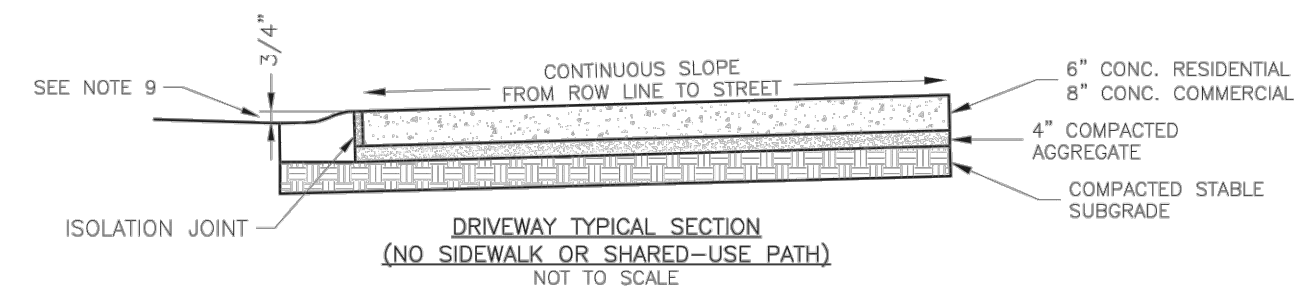

DRIVEWAY TYPICAL SECTION
(NO SIDEWALK OR SHARED-USE PATH)
NOT TO SCALE

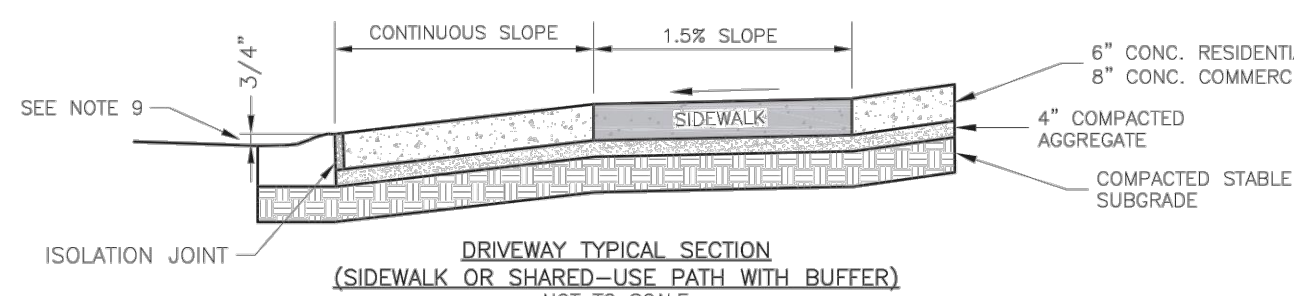

DRIVEWAY TYPICAL SECTION
(SIDEWALK OR SHARED-USE PATH WITH BUFFER)
NOT TO SCALE

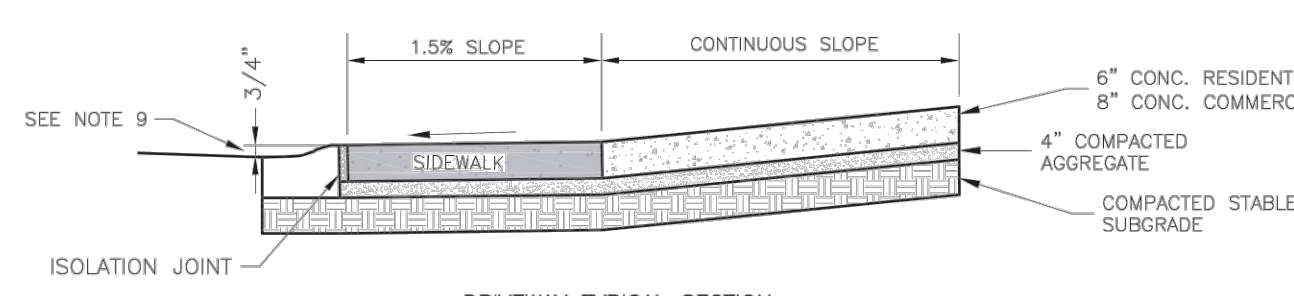

DRIVEWAY TYPICAL SECTION
(SIDEWALK OR SHARED-USE PATH WITHOUT BUFFER)
NOT TO SCALE

LEE'S SUMMIT MISSOURI
PUBLIC WORKS ENGINEERING DIVISION | 1230 SE GREEN STREET | LEE'S SUMMIT, MO 64063

STANDARD DETAILS
CITY OF LEE'S SUMMIT, MO
LEE'S SUMMIT, JACKSON COUNTY, MO

GEN-1

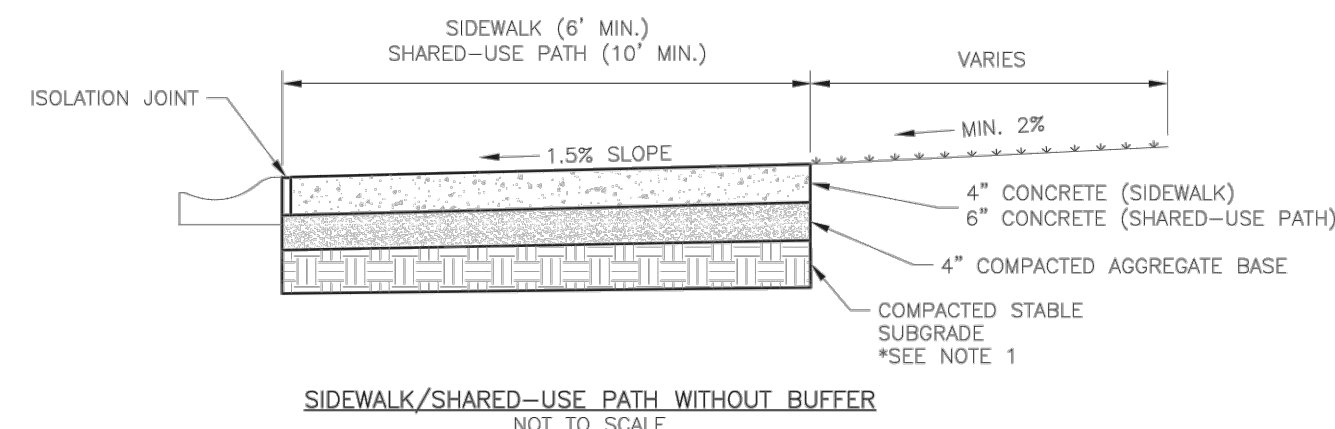

SIDEWALK/SHARED-USE PATH WITHOUT BUFFER
NOT TO SCALE

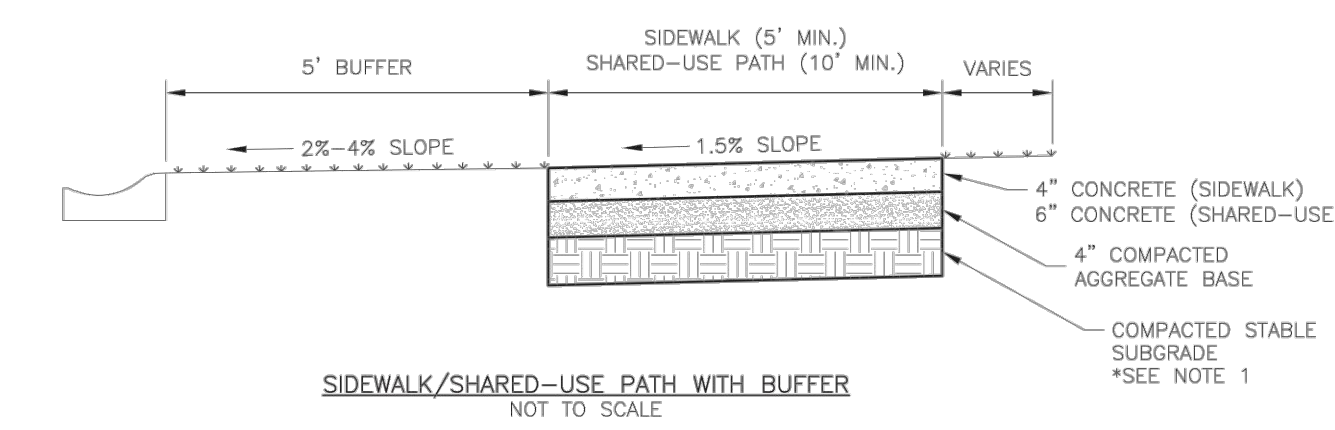

SIDEWALK/SHARED-USE PATH WITH BUFFER
NOT TO SCALE

- GENERAL NOTES:**
- SUBGRADE MUST BE OF STABLE, COMPACTED EARTH AND SHALL BE OVERLAYED WITH 4" COMPACTED DENSE GRADED AGGREGATE BASE.
 - 1.5% CROSS SLOPE MUST BE MAINTAINED THROUGH DRIVEWAYS.
 - KCMBB 4K CONCRETE MIX SHALL BE REQUIRED FOR ALL SIDEWALKS/SHARED-USE PATHS.
 - ALL SIDEWALK/SHARED-USE PATHS SHALL MEET CURRENT PUBLIC RIGHT OF WAY ACCESSIBILITY GUIDELINES (PROWAG).
 - AN ISOLATION JOINT SHALL BE PLACED AT A MAXIMUM OF 100 FT. CONSTRUCTION JOINTS SHALL BE PLACED THE SAME WIDTH OF SIDEWALK/SHARED-USE PATHS, BUT NO GREATER THAN 10 FT.
 - AN ISOLATION JOINT SHALL BE PLACED WHERE THE SIDEWALK/SHARED-USE PATHS MEETS A RESIDENTIAL DRIVEWAY.
 - SHARED-USE PATHS WIDTH SHALL BE 10 FT. WIDE.
 - SIDEWALK/SHARED-USE PATHS FINISHING SHALL BE FULL BROOM FINISH OR AS DIRECTED BY CITY INSPECTOR.
 - WHITE CURING COMPOUND MUST BE APPLIED UNIFORMLY TO THE CONCRETE SURFACE IMMEDIATELY AFTER FINAL FINISHING.

LEE'S SUMMIT MISSOURI
PUBLIC WORKS ENGINEERING DIVISION | 1230 SE GREEN STREET | LEE'S SUMMIT, MO 64063

GEN-2

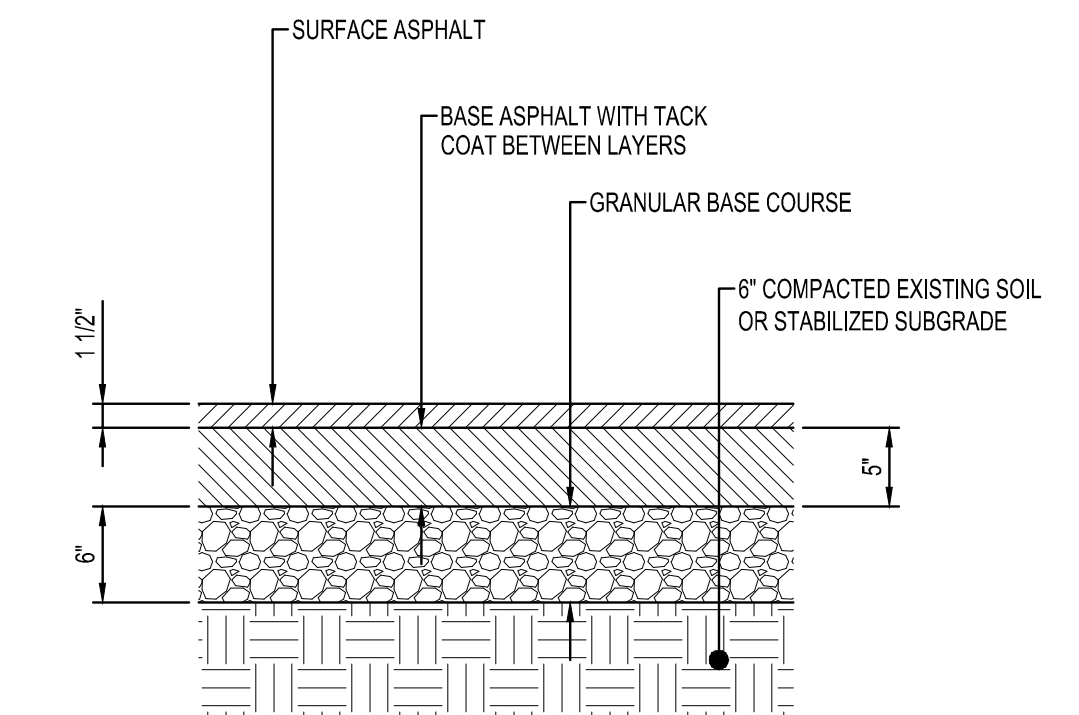

ASPHALT PAVEMENT
NTS

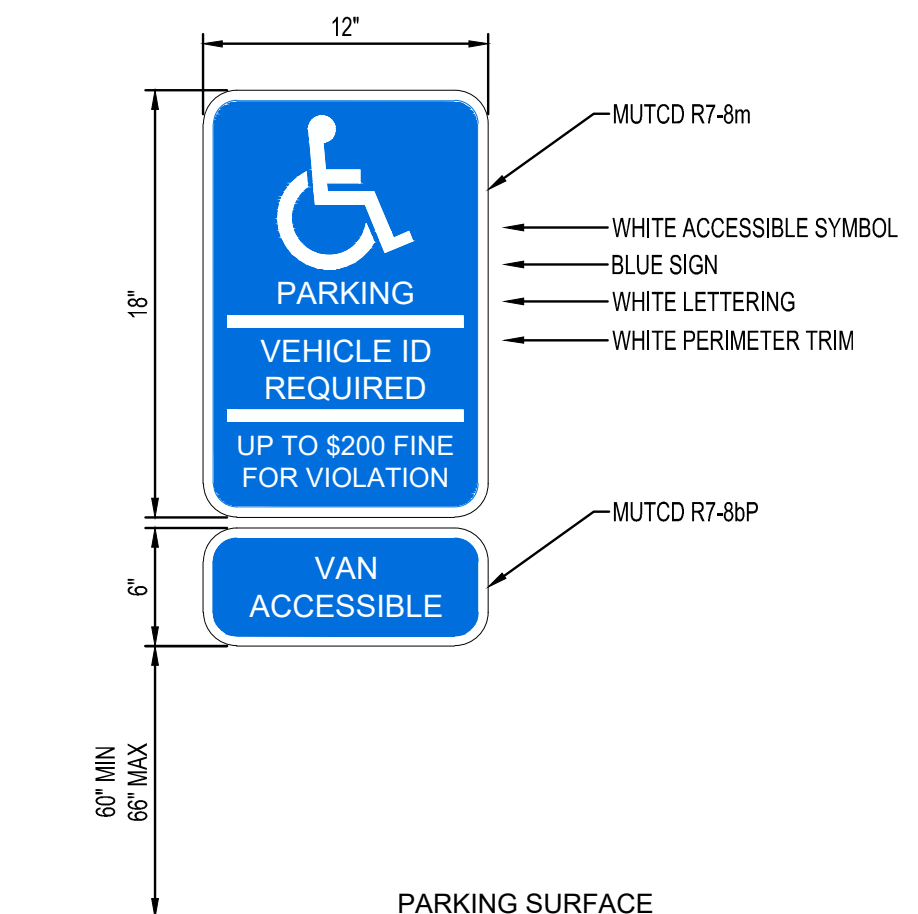

PARKING SURFACE
ACCESSIBLE PARKING SIGN
NTS

SHEET NOTES:

REVISIONS:

#	DATE	INITIALS	NOTES
1	05/20/2022	AJR	REVISED SET PER CITY COMMENTS
2	06/14/2022	ARA	REVISED SET PER CITY COMMENTS
3	09/27/2022	ARA	REVISED SET PER CITY COMMENTS

PROFESSIONAL SEAL:



THIS DOCUMENT IS THE PROPERTY OF I & S GROUP, INC. AND MAY NOT BE USED, COPIED OR DUPLICATED WITHOUT PRIOR WRITTEN CONSENT.

DES MOINES OFFICE
217 EAST 2nd STREET
SUITE 110
DES MOINES, IA 50309
PHONE: 515.243.9143
PROJECT MANAGER: RYAN ANDERSON
EMAIL: RYAN.ANDERSON@ISG.COM

THESE PLANS HAVE BEEN PREPARED BY
AMERCO
REAL ESTATE COMPANY

CONSTRUCTION DEPARTMENT
2721 NORTH CENTRAL AVENUE
PHOENIX, ARIZONA 85004
PH: (602) 263-4502

SITE ADDRESS:
U-Haul Moving & Storage
710 SE BLUE PARKWAY
LEE'S SUMMIT, MO

SHEET CONTENTS:

SITE DETAILS

DRAWN: AJR
CHECKED: AA
DATE: 04/22/22

C6-10

26154 CD DETAILS

©2022 AMERCO REAL ESTATE COMPANY

PRELIMINARY NOT FOR CONSTRUCTION

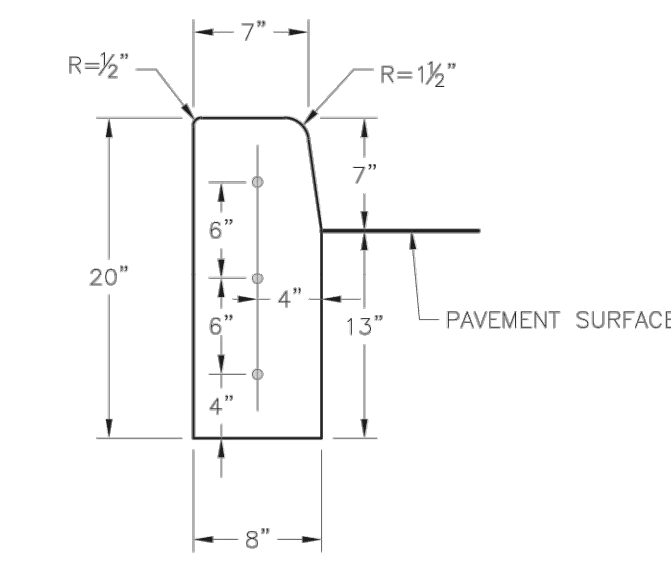

STRAIGHT CURB
(TYPE C-1)

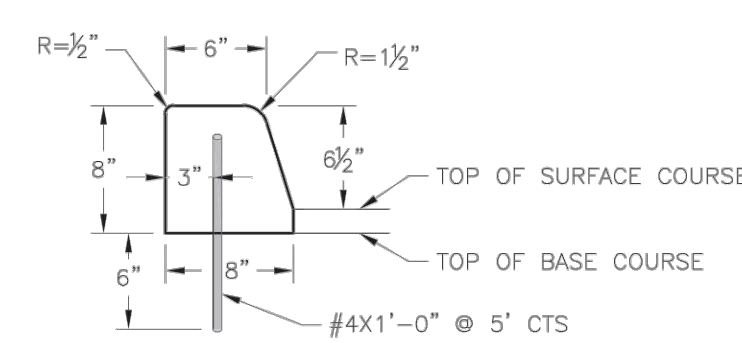

DOWELLED CURB
(TYPE DC)

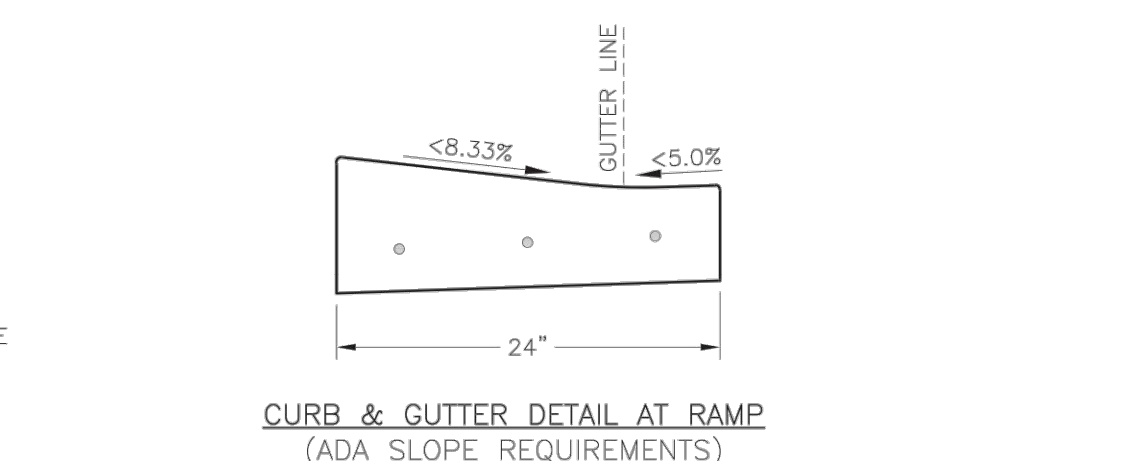

CURB & GUTTER DETAIL AT RAMP
(ADA SLOPE REQUIREMENTS)

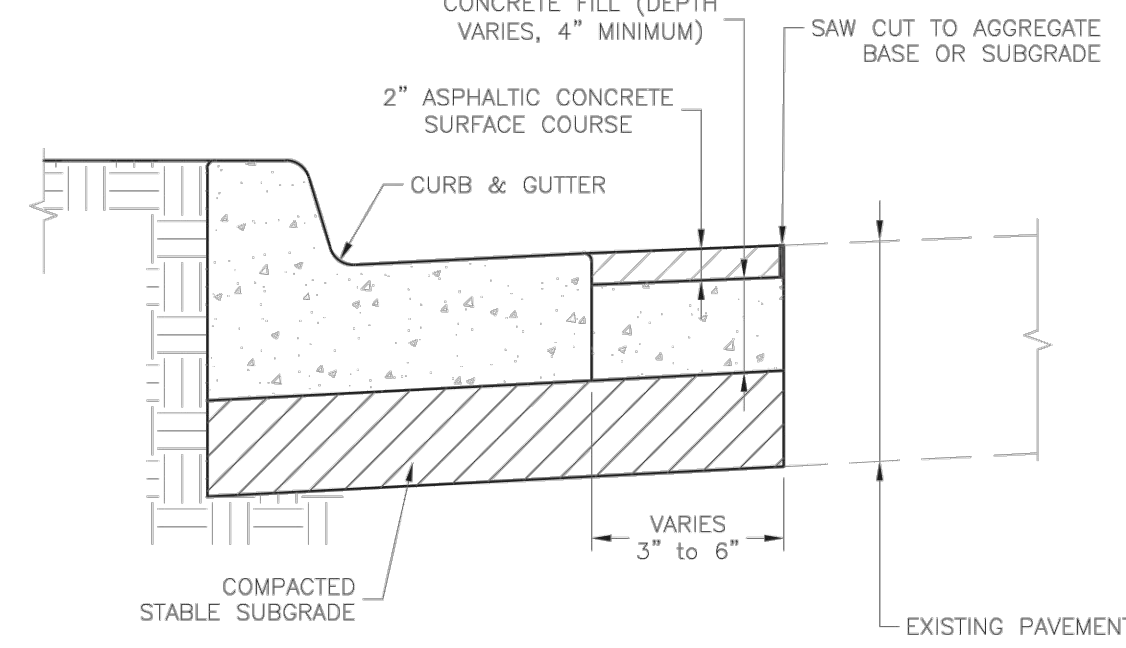

CURB REPLACEMENT DETAIL

- GENERAL NOTES:**
- 3/4" ISOLATION JOINTS WITH 3 (2'-#5 BAR) SMOOTH DOWELS SHALL BE PLACED AT RADIUS POINTS AND AT 150' INTERVALS. THESE DOWEL BARS SHALL BE GREASED AND WRAPPED ON ONE END WITH EXPANSION TUBES.
 - 3" DEEP CONTRACTION JOINTS SHALL BE INSTALLED AT APPROXIMATELY 10' INTERVALS. THESE JOINTS SHALL PASS ACROSS THE ENTIRE CURB SECTION.
 - CONCRETE FILL SHALL HAVE UNIFORM AND SMOOTH FINISH.
 - KCMBB 4K CONCRETE SHALL BE USED FOR ALL CURB.
 - ASPHALTIC CONCRETE SURFACE COURSE SHALL CONFORM TO STANDARD SPECIFICATIONS SECTION 2205.2.
 - CURBS FOR NEW STREETS SHALL BE BUILT ON ASPHALT OR AGGREGATE BASE AS SHOWN IN TYPICAL SECTION DETAIL.
 - WHITE CURING COMPOUND MUST BE APPLIED UNIFORMLY TO THE CONCRETE SURFACE IMMEDIATELY AFTER FINAL FINISHING.
 - ALL DOWELS & TIE BARS SHALL BE EPOXY COATED.

LEE'S SUMMIT MISSOURI
PUBLIC WORKS ENGINEERING DIVISION | 1230 SE GREEN STREET | LEE'S SUMMIT, MO 64063

STANDARD DETAILS
CITY OF LEE'S SUMMIT, MO
LEE'S SUMMIT, JACKSON COUNTY, MO

GEN-4

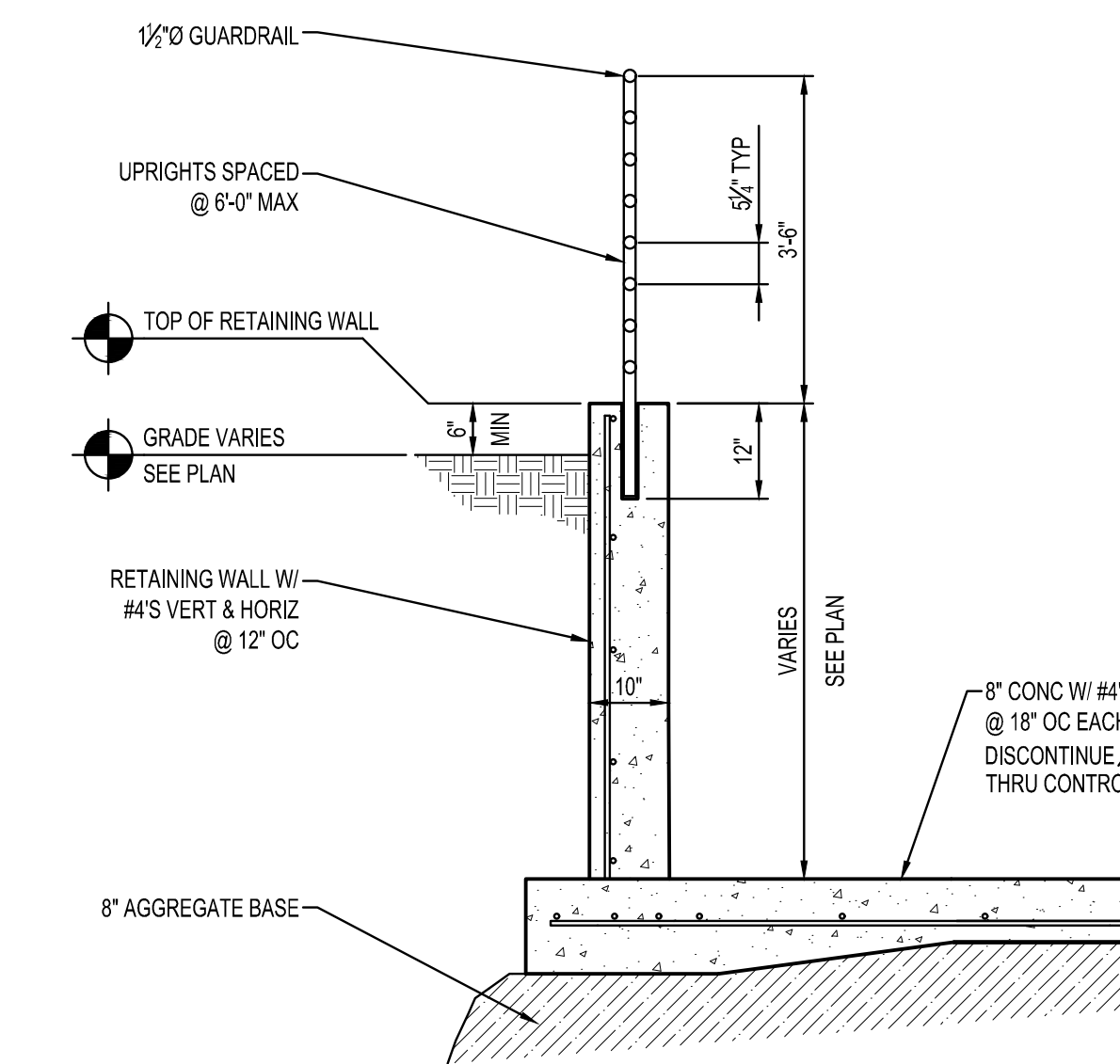

RETAINING WALL SECTION
NTS

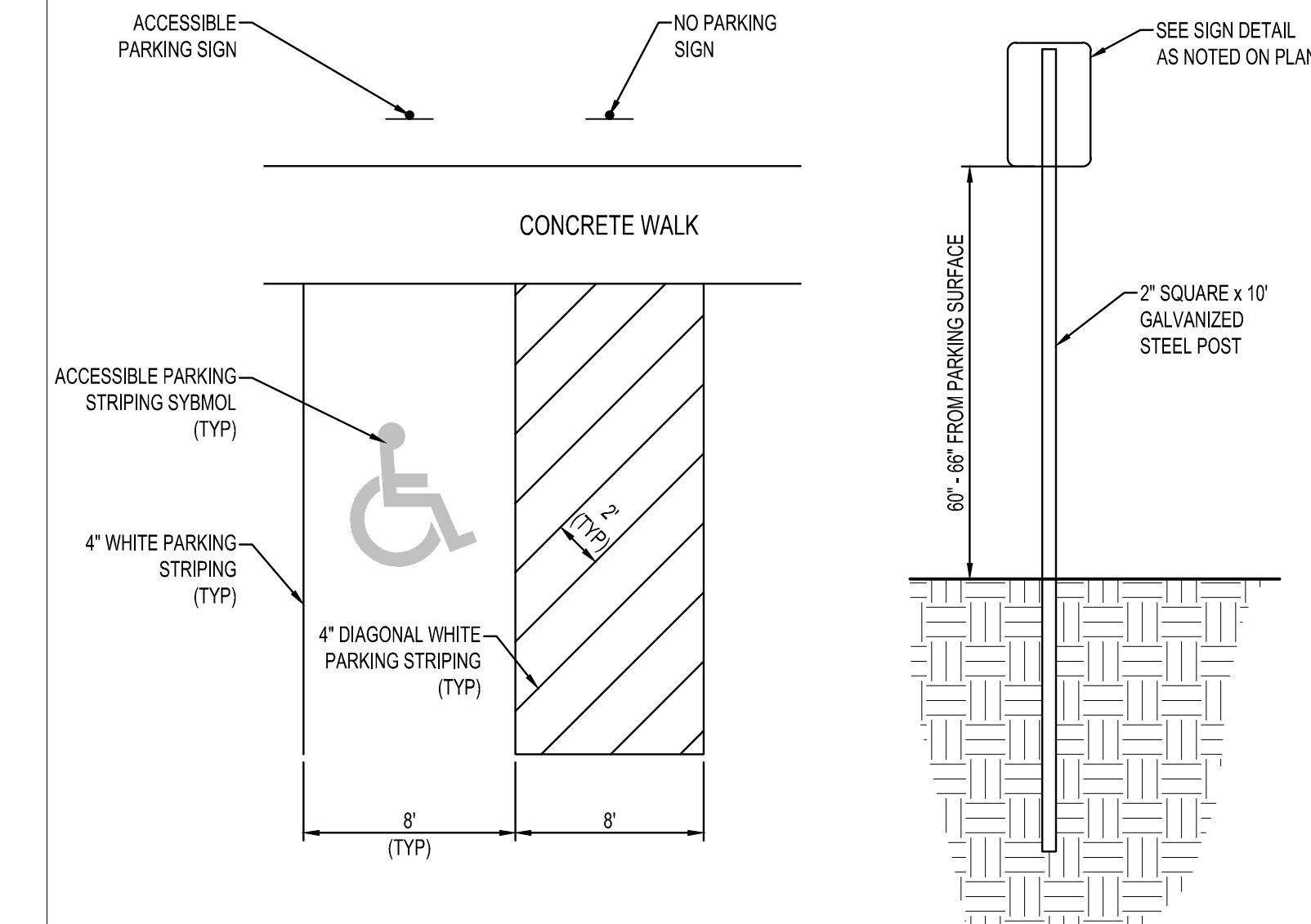

ACCESSIBLE PARKING AREA
NTS

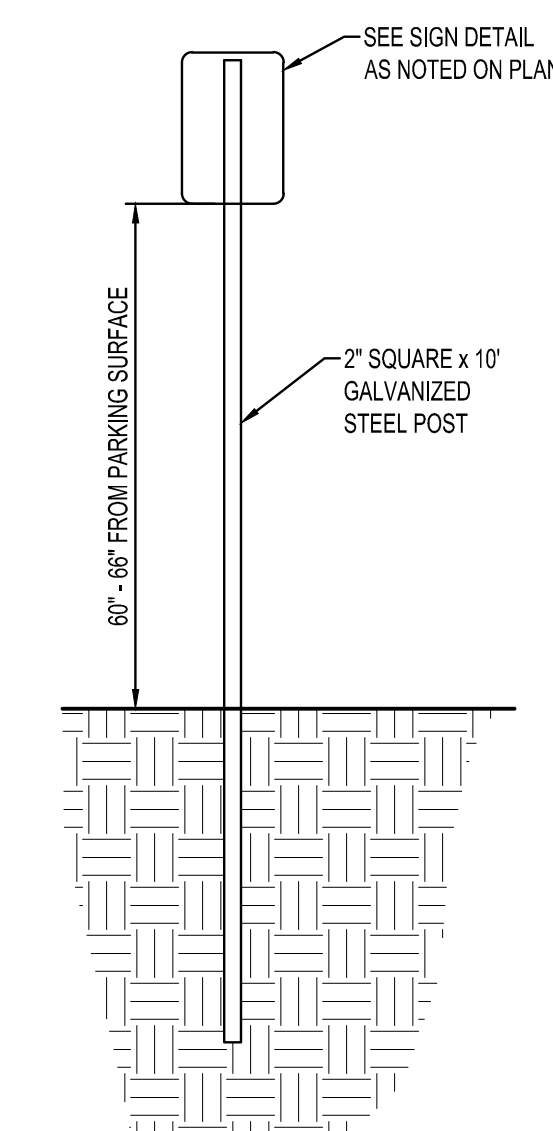

SIGN POST
NTS

PLANT SCHEDULE

GROUND COVERS	QTY	BOTANICAL / COMMON NAME
	6,557 SF	MULCH SHREDED HARDWOOD MULCH
	48,086 SF	TURF SOD 90% TALL FESCUE, 10% KENTUCKY BLUEGRASS

PLANT SCHEDULE

EVERGREEN TREES	QTY	BOTANICAL / COMMON NAME	SIZE	ROOT
IV	7	ILEX VOMITORIA YAUPON HOLLY	8' HT MIN	B & B
PW	6	PINUS ALBA WHITE PINE	8' HT MIN	B & B
PT	6	PINUS TAEDA LOBLOLLY PINE	8' HT MIN	B & B
TD	7	TAXODIUM DISTICHUM BALD CYPRESS	8' HT MIN	B & B
ORNAMENTAL TREES	QTY	BOTANICAL / COMMON NAME	SIZE	ROOT
CC	16	CERCIS CANADENSIS EASTERN REDBUD	2" CAL	B & B
CF	19	CORNUS FLORIDA FLOWERING DOGWOOD	2" CAL	B & B
SHADE TREES	QTY	BOTANICAL / COMMON NAME	SIZE	ROOT
AR	7	ACER RUBRUM RED MAPLE	3" CAL	B & B
QP	4	QUERCUS PALUSTRIS PIN OAK	3" CAL	B & B
QS	6	QUERCUS SHUMARDII SHUMARD OAK	3" CAL	B & B
UP	13	ULMUS PARVIFOLIA 'EMER II' TM ALLEE LACEBARK ELM	3" CAL	B & B
SHRUBS	QTY	BOTANICAL / COMMON NAME	SIZE	ROOT
JO	8	JUNIPERUS VIRGINIANA 'GREY OWL' GREY OWL EASTERN REDCEDAR	3 GAL	CONT
LB	18	LINDERA BENZOIN SPICEBUSH	3 GAL	CONT
PN	31	PHYSCARPUS OPULIFOLIUS NINEBARK	3 GAL	CONT
RG	43	RHUS AROMATICA 'GRO-LOW' GRO-LOW FRAGRANT SUMAC	3 GAL	CONT
VL	23	VIBURNUM LENTAGO NANNYBERRY	5 GAL	CONT
GRASSES	QTY	BOTANICAL / COMMON NAME	SIZE	ROOT
CA	27	CALAMAGROSTIS X ACUTIFLORA FEATHER REED GRASS	3 GAL	

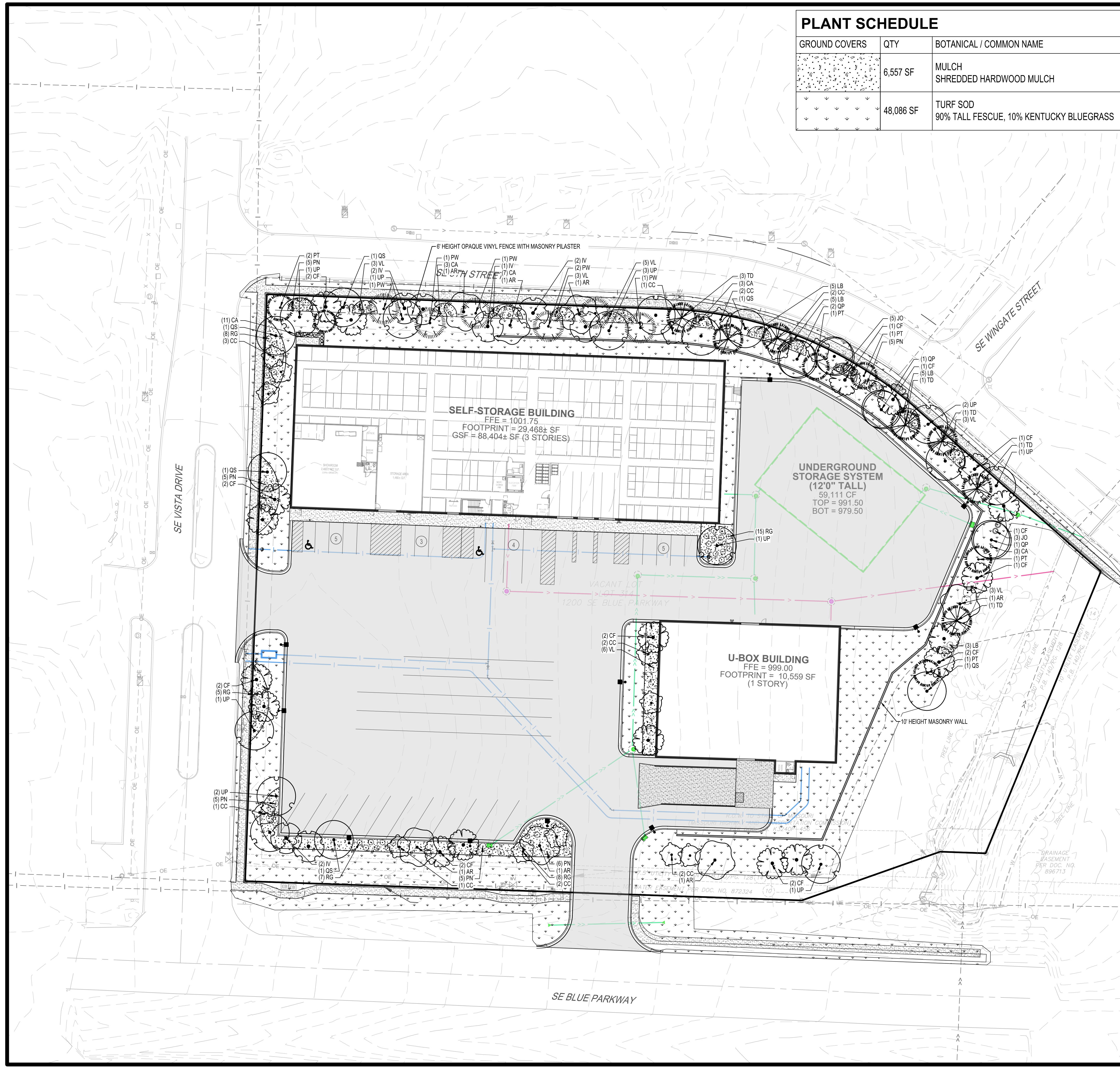

CITY OF LEE'S SUMMIT LANDSCAPE REQUIREMENTS

STREET FRONTAGE
 REQUIREMENTS: 1 TREE PER 30 LF STREET FRONTAGE, 1 SHRUB PER 20 LF STREET FRONTAGE
 SE VISTA DR - 380 LF STREET FRONTAGE = 13 TREES, 20 SHRUBS
 SE BLUE PKWY - 490 LF STREET FRONTAGE = 16 TREES, 25 SHRUBS
 PROVIDED: SE VISTA DR - 13 TREES, 23 SHRUBS
 SE BLUE PKWY - 16 TREES, 26 SHRUBS

OPEN YARD AREAS
 REQUIREMENTS: 1 TREE AND 2 SHRUBS FOR EVERY 5,000 SF OF LOT AREA, EXCLUDING BUILDING
 139,115 SF / 5,000 = 28 TREES, 56 SHRUBS REQUIRED
 PROVIDED: 40 TREES, 72 SHRUBS

PARKING LOT LANDSCAPE
 REQUIREMENTS: LANDSCAPE ISLANDS SHALL CONSTITUTE AT LEAST 5% OF TOTAL AREA OF PARKING SPACES, AISLES, AND DRIVEWAYS. LANDSCAPE ISLANDS SHALL BE NO LESS THAN 9 FT WIDE AND PLANTED.
 PROVIDED: 5.16% OF TOTAL AREA IS LANDSCAPE ISLANDS, 9' MIN WIDTH.

LAND USE BUFFER SCREEN - NORTH (SE 8TH ST)
 REQUIREMENTS:
 HIGH IMPACT SCREENING BETWEEN CP-2 & RP-2
 20' WIDTH LANDSCAPE BUFFER
 6' HEIGHT MASONRY WALL OR OPAQUE VINYL FENCE WITH MASONRY PILASTERS
 LOW IMPACT SCREENING OPTION C (11,500 SF TOTAL)
 SHADE TREES - 11,560 / 750 SF = 16 TREES
 ORNAMENTAL TREES - 11,560 / 750 SF = 16 TREES
 EVERGREEN TREES - 11,560 / 750 SF = 16 TREES
 SHRUBS - 11,560 / 200 SF = 58 SHRUBS
 PROVIDED:
 20' WIDTH LANDSCAPE BUFFER
 6' OPAQUE VINYL FENCE WITH MASONRY PILASTERS
 LOW IMPACT SCREENING OPTION C
 16 SHADE, ORNAMENTAL, AND EVERGREEN TREES EACH
 58 SHRUBS

LAND USE BUFFER SCREEN - EAST (ADJACENT HOUSING DEVELOPMENT)
 REQUIREMENTS:
 HIGH IMPACT SCREENING BETWEEN CP-2 & RP-3
 20' WIDTH LANDSCAPE BUFFER
 6' HEIGHT MASONRY WALL OR OPAQUE VINYL FENCE WITH MASONRY PILASTERS
 LOW IMPACT SCREENING OPTION C (2,420 SF TOTAL)
 SHADE TREES - 2,420 / 750 SF = 3 TREES
 ORNAMENTAL TREES - 2,420 / 750 SF = 3 TREES
 EVERGREEN TREES - 2,420 / 750 SF = 3 TREES
 SHRUBS - 2,420 / 200 SF = 12 SHRUBS
 PROVIDED:
 20' WIDTH LANDSCAPE BUFFER
 10' HEIGHT MASONRY WALL
 LOW IMPACT SCREENING OPTION C
 3 SHADE, ORNAMENTAL, AND EVERGREEN TREES EACH
 12 SHRUBS

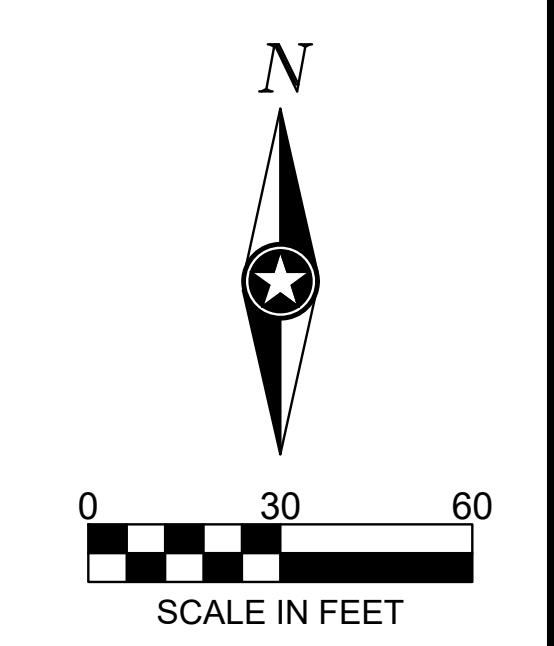

SHEET NOTES:

REVISIONS:	
#	DATE
1	05/02/2022
2	06/14/2022
3	09/27/2022

PROFESSIONAL SEAL:

THIS DOCUMENT IS THE PROPERTY OF I & S GROUP, INC. AND MAY NOT BE USED, COPIED OR DUPLICATED WITHOUT PRIOR WRITTEN CONSENT.

DES MOINES OFFICE
 217 EAST 2nd STREET
 SUITE 110
 DES MOINES, IA 50309
 PHONE: 515.243.9143
 PROJECT MANAGER: RYAN ANDERSON
 EMAIL: RYAN.ANDERSON@ISG.COM

THESE PLANS HAVE BEEN PREPARED BY

CONSTRUCTION DEPARTMENT
 2721 NORTH CENTRAL AVENUE
 PHOENIX, ARIZONA 85004
 PH: (602) 263-6502

SITE ADDRESS:
 U-Haul Moving & Storage
 710 SE BLUE PARKWAY
 LEE'S SUMMIT, MO

SHEET CONTENTS:
PLANTING AND RESTORATION PLAN

DRAWN:	AJR	C7-10
CHECKED:	AA	
DATE:	04/22/22	

26154 06 LANDSCAPE

PRELIMINARY NOT FOR CONSTRUCTION

©2022 AMERCO REAL ESTATE COMPANY

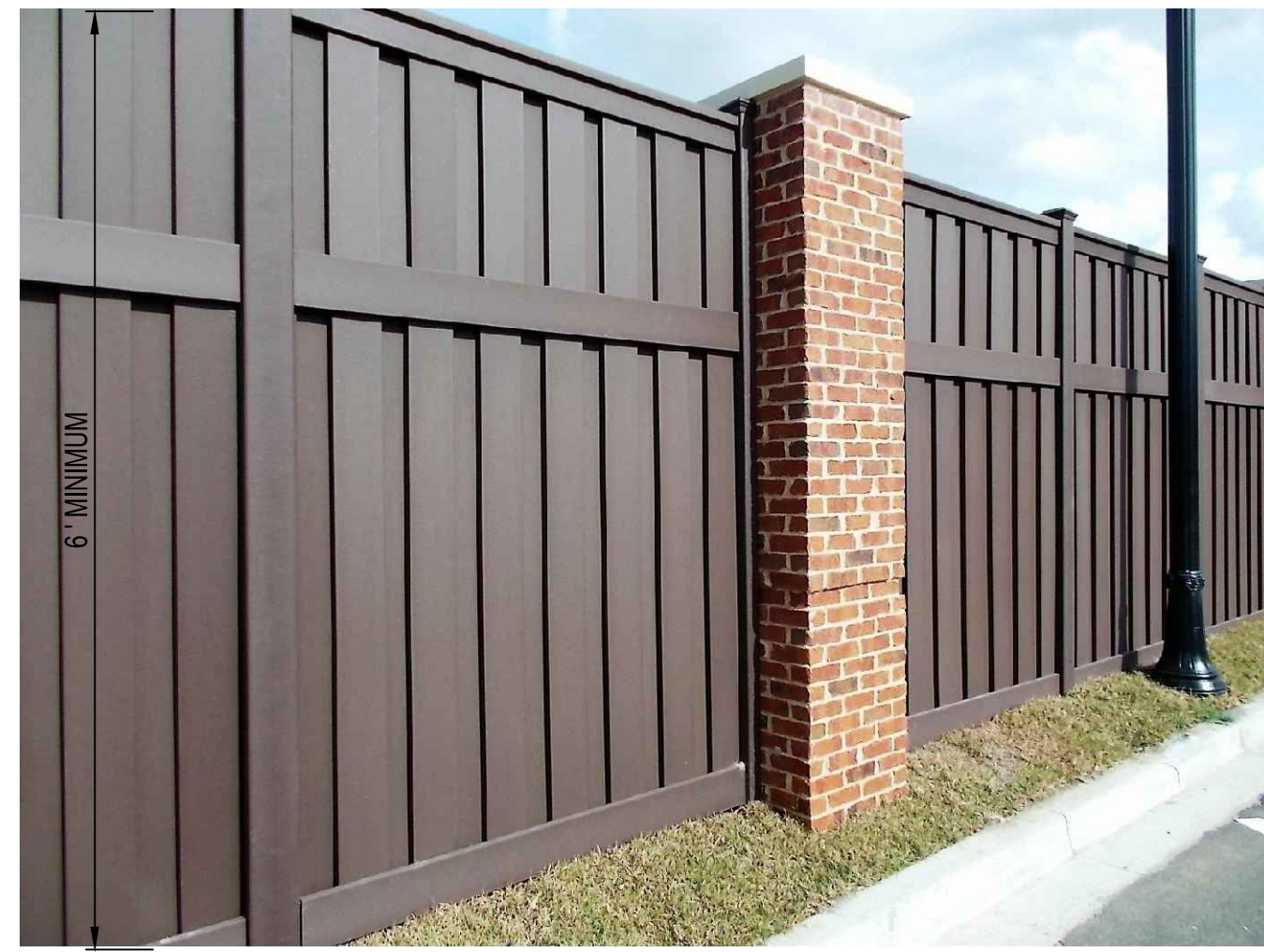

HIGH IMPACT SCREEN REQUIREMENTS
 SCREEN SHALL BE 100 PERCENT OPAQUE
 SCREEN SHALL BE A MINIMUM OF 6 FEET TALL
 SCREEN SHALL BE OPAQUE VINYL FENCE WITH MASONRY PILASTERS OR MASONRY WALL

MANUFACTURER INFORMATION
 EVEREST PRIVACY STYLE FENCING

CONTRACTOR TO SUBMIT SHOP DRAWINGS FOR REVIEW

6' HEIGHT OPAQUE VINYL FENCE WITH MASONRY PILASTER

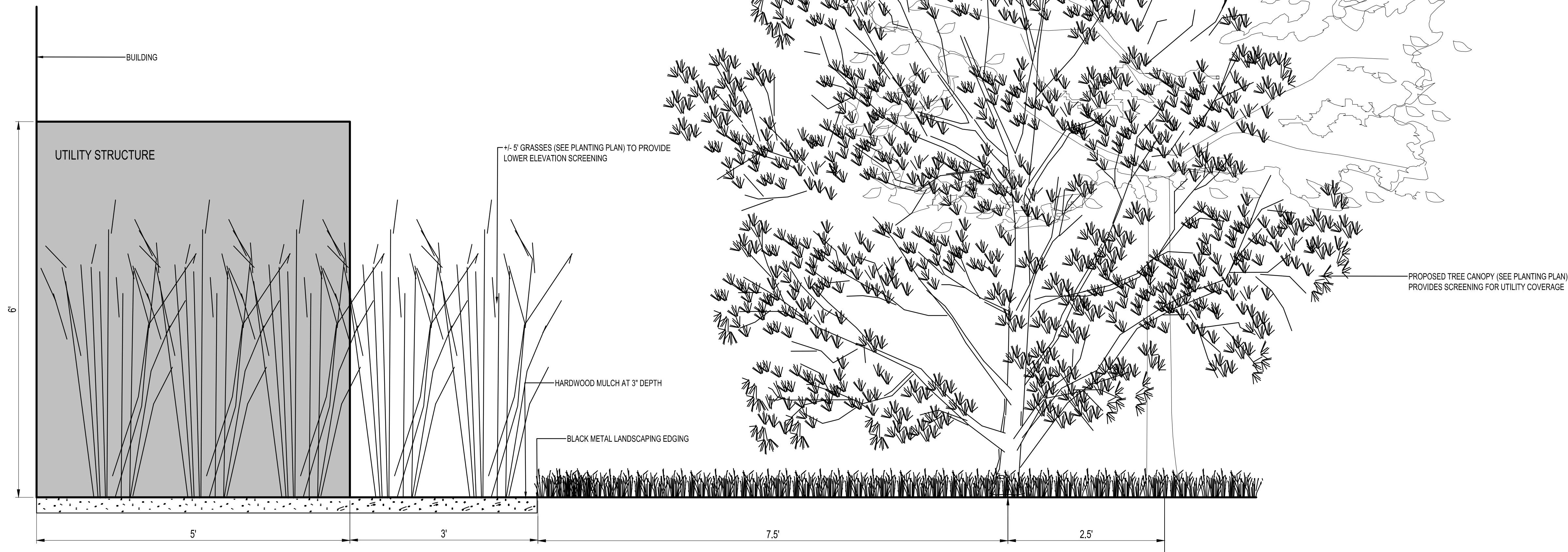

UTILITY SCREENING DETAIL
 NTS

SHEET NOTES:

REVISIONS:

#	DATE	INITIALS	NOTES
1	05/02/2022	AJR	REVISED SET PER CITY COMMENTS
2	06/14/2022	ARA	REVISED SET PER CITY COMMENTS
3	09/27/2022	ARA	REVISED SET PER CITY COMMENTS

PROFESSIONAL SEAL:



THIS DOCUMENT IS THE PROPERTY OF I & S GROUP, INC. AND MAY NOT BE USED, COPIED OR DUPLICATED WITHOUT PRIOR WRITTEN CONSENT.

DES MOINES OFFICE
 217 EAST 2nd STREET
 SUITE 110
 DES MOINES, IA 50309
 PHONE: 515.243.9143
 PROJECT MANAGER: RYAN ANDERSON
 EMAIL: RYAN.ANDERSON@ISG.COM

THESE PLANS HAVE BEEN PREPARED BY
AMERCO
 REAL ESTATE COMPANY

CONSTRUCTION DEPARTMENT
 2727 NORTH CENTRAL AVENUE
 PHOENIX, ARIZONA 85004
 PH: (602) 263-6502

SITE ADDRESS:
 U-Haul Moving & Storage
 710 SE BLUE PARKWAY
 LEE'S SUMMIT, MO

SHEET CONTENTS:
LANDSCAPE DETAILS

DRAWN: AJR
 CHECKED: AA
 DATE: 04/22/22
C7-20

©2022 AMERCO REAL ESTATE COMPANY

26154 CG LANDSCAPE

PRELIMINARY NOT FOR CONSTRUCTION

LIGHT FIXTURE SCHEDULE							
SYMBOL	TYPE	MANUFACTURER	CATALOG NUMBER	DESCRIPTION	LAMP	WATTAGE	HEIGHT
	W	LITHONIA	WST LED P3 40K VF MVOLT	WALLPACK	HIGH-EFFICACY LED FULL CUTOFF	20	20'-0"
	Z	LITHONIA	DSX2 LED P1 40K T4M MVOLT HS	POLE MOUNTED SINGLE HEAD	HIGH-EFFICACY LED FULL CUTOFF	140	15'-0"
	Z1	LITHONIA	DSX2 LED P1 40K T4M MVOLT HS	POLE MOUNTED SINGLE HEAD	HIGH-EFFICACY LED FULL CUTOFF	140	20'-0"

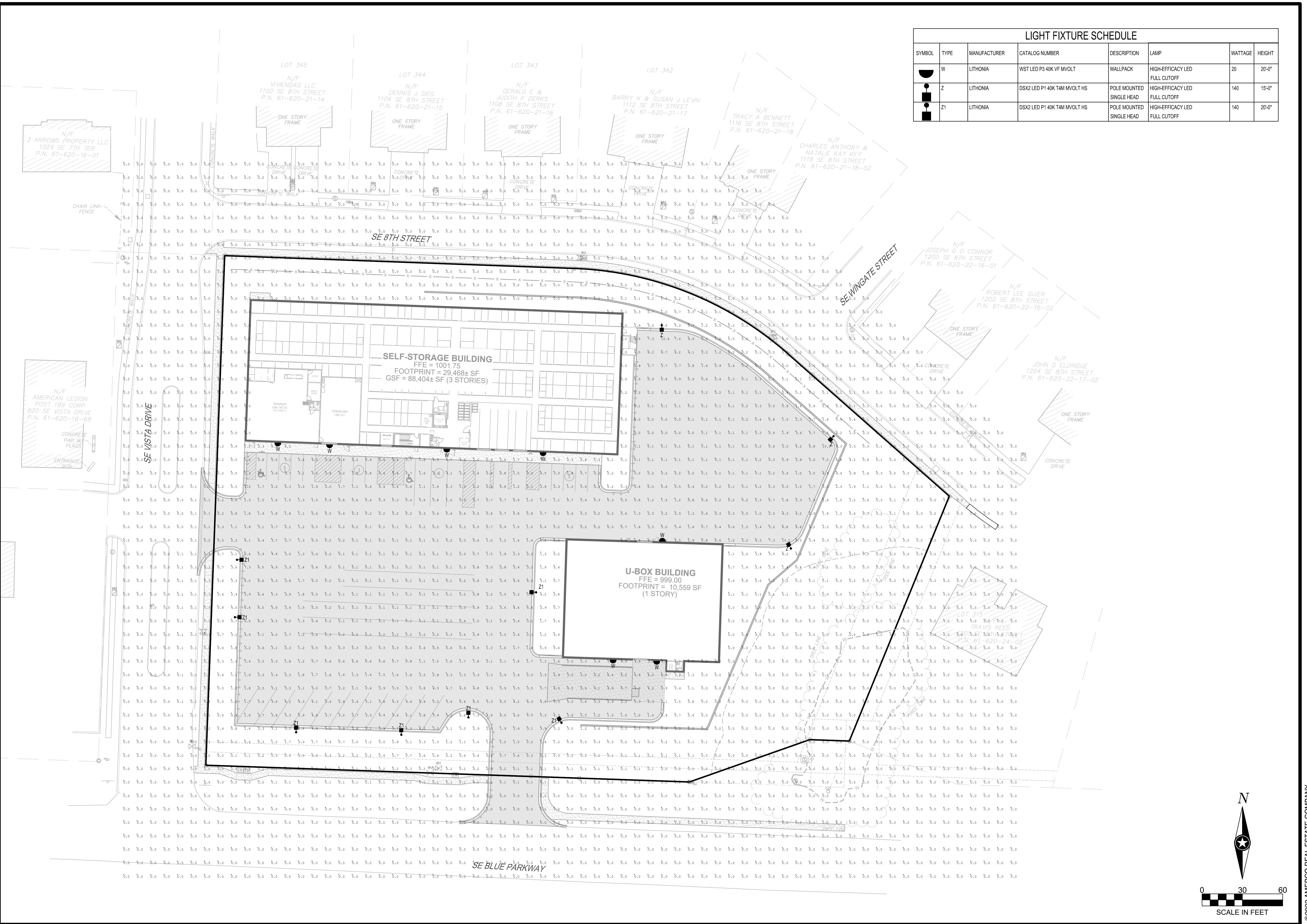

REVISIONS:

#	DATE	INITIALS	NOTES
1	05/02/22	AR	REVISED SET PER CITY COMMENTS
2	06/14/22	ARA	REVISED SET PER CITY COMMENTS
3	09/27/22	ARA	REVISED SET PER CITY COMMENTS

PROFESSIONAL SEAL:



THIS DOCUMENT IS THE PROPERTY OF ISG GROUP, INC. AND MAY NOT BE USED, COPIED OR DUPLICATED WITHOUT PRIOR WRITTEN CONSENT.

DES MOINES OFFICE
217 EAST 2nd STREET
SUITE 110
DES MOINES, IA 50309
PHONE: 515.243.9143
PROJECT MANAGER: RYAN ANDERSON
EMAIL: RYAN.ANDERSON@ISG.COM

THESE PLANS HAVE BEEN PREPARED BY
AMERCO
REAL ESTATE COMPANY

CONSTRUCTION DEPARTMENT
2721 NORTH CENTRAL AVENUE
PHOENIX, ARIZONA 85004
PH: (602) 263-6502

SITE ADDRESS:
U-Haul Moving & Storage
710 SE BLUE PARKWAY
LEE'S SUMMIT, MO

SHEET CONTENTS:
PHOTOMETRIC PLAN

DRAWN: AJR
CHECKED: AA
DATE: 04/22/22
E1-10

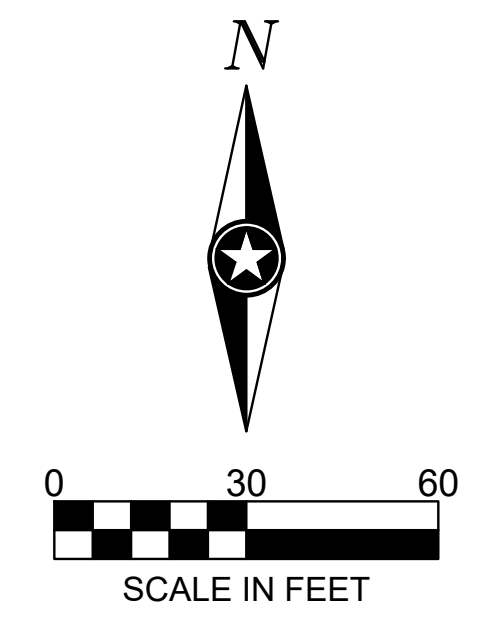

PRELIMINARY NOT FOR CONSTRUCTION

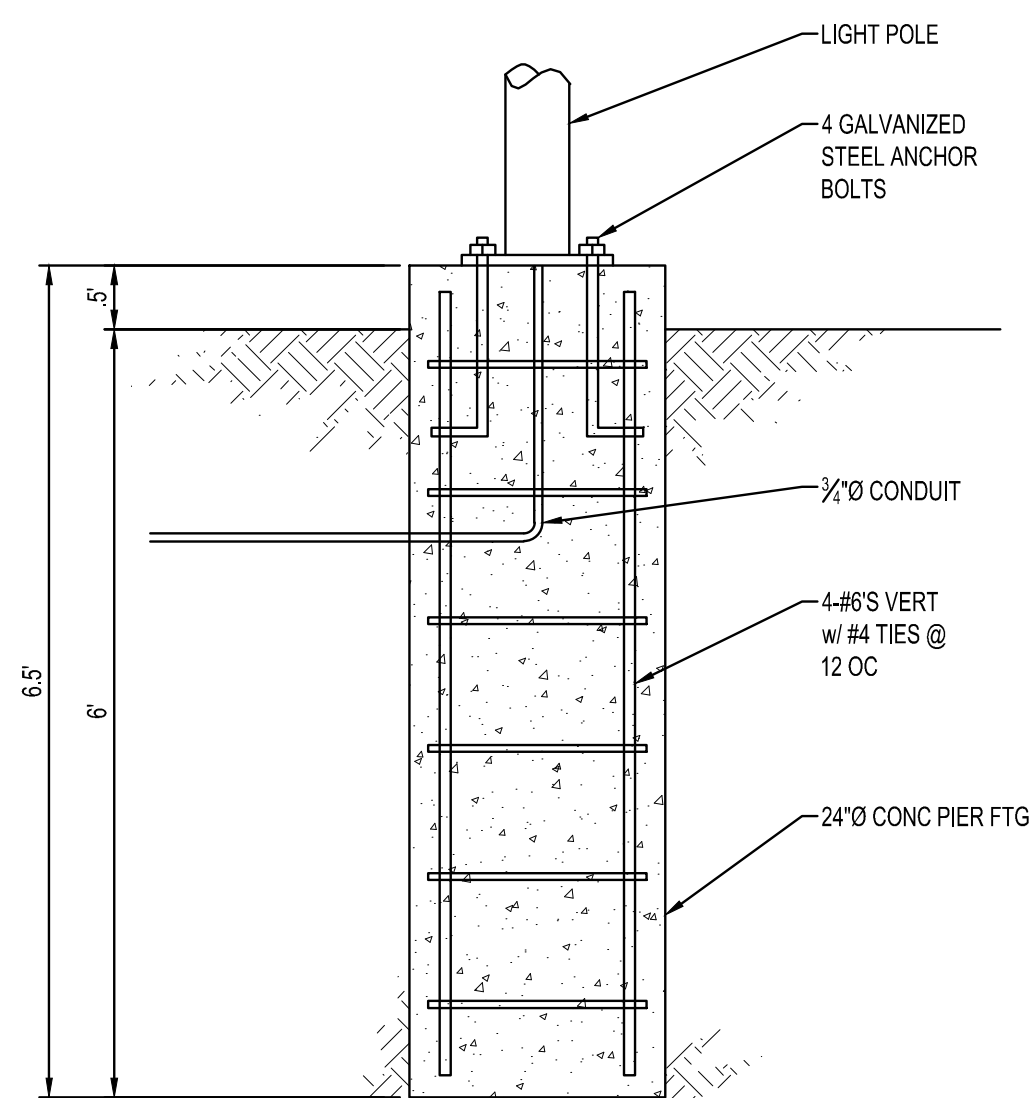

NOTES:

LIGHT POLE BASE INSTALLED AND PROVIDED BY ELECTRICAL CONTRACTOR

ROUND LIGHT POLE BASE NTS LT100



TYPE W WST LED Architectural Wall Sconce



Specifications Luminaire

Height: 8.1/2" (21.59 cm) Width: 7" (17.78 cm) Depth: 10.3/16" (25.9 cm) Weight: 20 lbs (9.1 kg)

Optional Back Box (PBBW)

Height: 8.49" (21.56 cm) Width: 17.01" (43.21 cm) Depth: 1.70" (4.32 cm)

Optional Back Box (BBW)

Height: 4" (10.2 cm) Width: 5.1/2" (14.0 cm) Depth: 1.1/2" (3.8 cm)

Table with 3 columns: Catalog Number, Notes, Type.

Capable Luminaire

This item is an A+ capable luminaire, which has been designed and tested to provide consistent color appearance and system-level interoperability.

- All configurations of this luminaire meet the Acuity Brands' specification for chromatic consistency. This luminaire is A+ Certified when ordered with DTL* controls marked by a shaded background. DTL, DLL equipped luminaires meet the A+ specification for luminaire to photocell interoperability. This luminaire is part of an A+ Certified solution for ROAM* or XPoint™ Wireless control networks, providing out-of-the-box control compatibility with simple commissioning, when ordered with drivers and control options marked by a shaded background.

To learn more about A+, visit www.acuitybrands.com/anplus.

See ordering tree for details.

A+ Certified Solutions for ROAM require the order of one ROAM node per luminaire. Sold Separately: Link to Roam; Link to DTL, DLL.



TYPE Z & Z1 D-Series Size 2 LED Area Luminaire

Specifications EPA: 1.1 ft (0.33 m) Length: 40" (101.6 cm) Width: 15" (38.1 cm) Height 1: 7.1/4" (18.4 cm) Height 2: 3.5" (8.9 cm) Weight: 36lbs

Table with 3 columns: Catalog Number, Notes, Type.

Introduction

The modern styling of the D-Series is striking yet unobtrusive - making a bold, progressive statement even as it blends seamlessly with its environment.

The D-Series distills the benefits of the latest in LED technology into a high performing, high efficacy, long-life luminaire. The outstanding photometric performance results in sites with excellent uniformity, greater pole spacing and lower power density. The Size 2 is ideal for replacing 400-1000W metal halide in area lighting applications with energy savings of up to 80% and expected service life of over 100,000 hours.

Ordering Information EXAMPLE: DSX2 LED P7 40K T3M MVOLT SPA NLTAR2 PIRHN DDBXD

Table with columns: Series, LED, Color temperature, Distribution, Voltage, Mounting.

Table with columns: Control options, Shipped installed, Other options, Finish.

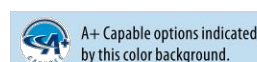

Ordering Information EXAMPLE: WST LED P1 40K VF MVOLT DDBTDX

Table with columns: Series, Performance Package, Color temperature, Distribution, Voltage, Mounting.

Table with columns: System, Finish, Options.

Accessories

- WSTVWB080D Premium Surface-mounted back box. WSBW080D10 Surface-mounted back box. BPR080D10 Remotely back box. DL127F 1.5 CU.J Photocell - SS, twist lock (120-277V). DL147F 1.5 CU.J Photocell - SS, twist lock (240V). DL148F 1.5 CU.J Photocell - SS, twist lock (480V).

NOTES

- MVOLT driver operates on any line voltage from 120-277V (50/60 Hz). Single fuse (SF) requires 120V, 277V or 347V. Double fuse (DF) requires 208V, 240V or 480V. Also available as a separate accessory; see accessories information. Top conduit entry standard. Not available with VG or WG. See PER Table. Reference Motion Sensor table. Not available with 347/480V. Need to specify 120, 208, 240 or 277 voltage. Photocell ordered and shipped as a separate line item from Acuity Brands Controls. Shorting Cap included.

Emergency Battery Operation

The emergency battery backup is integral to the luminaire - no external housing required! This design provides reliable emergency operation while maintaining the aesthetics of the product. All emergency backup configurations include an independent secondary driver with an integral relay to immediately detect AC power loss, meeting interpretations of NFPA 70/NFPA 70NEC 2008 - 700.16. The emergency battery will power the luminaire for a minimum duration of 90 minutes (maximum duration of three hours) from the time supply power is lost, per International Building Code Section 1006 and NFPA 101, Life Safety Code Section 7.9, provided luminaires are mounted at an appropriate height and illuminate an open space with no major obstructions. The examples below show illuminance of 1 fc average and 0.1 fc minimum of the P1 power package and VF distribution product in emergency mode.

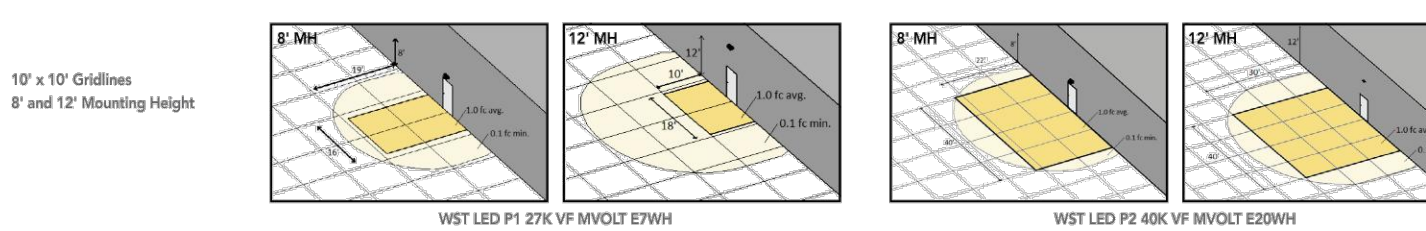

Ordering Information

Table with columns: Accessories, NOTES.

Options

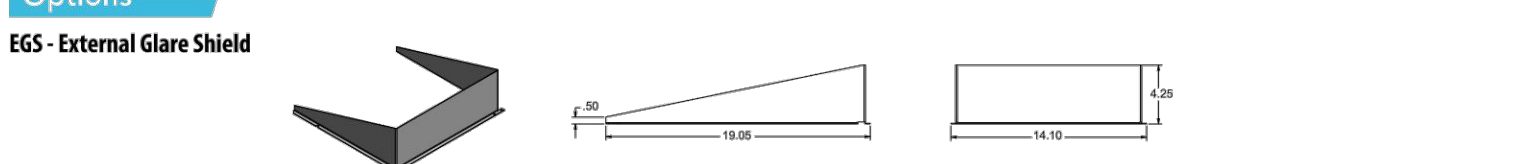

Drilling

Table with columns: Mounting Option, Drilling Template, Tenon Mounting Slipfitter.

DSX2 Area Luminaire - EPA

Table with columns: Fixture Quantity & Mounting Configuration, Mounting Type, Drilling Template, Minimum Acceptable Outside Pole Dimension.

REVISIONS:

Table with columns: #, DATE, INITIALS, DESCRIPTION.

PROFESSIONAL SEAL:



THIS DOCUMENT IS THE PROPERTY OF I & S GROUP, INC. AND MAY NOT BE USED, COPIED OR DUPLICATED WITHOUT PRIOR WRITTEN CONSENT.

DES MOINES OFFICE 217 EAST 2ND STREET SUITE 110 DES MOINES, IA 50309 PHONE: 515.243.9143 PROJECT MANAGER: RYAN ANDERSON EMAIL: RYAN.ANDERSON@ISG.COM

THESE PLANS HAVE BEEN PREPARED BY AMERCO REAL ESTATE COMPANY

CONSTRUCTION DEPARTMENT 2727 NORTH CENTRAL AVENUE PHOENIX, ARIZONA 85004 PH: (602) 263-6502

SITE ADDRESS: U-Haul Moving & Storage 710 SE BLUE PARKWAY LEE'S SUMMIT, MO

SHEET CONTENTS: PHOTOMETRIC DETAILS

DRAWN: AJR CHECKED: AA DATE: 04/22/22 E1-11

PRELIMINARY NOT FOR CONSTRUCTION

©2022 AMERCO REAL ESTATE COMPANY