



LAND CLEARANCE FOR REDEVELOPMENT  
AUTHORITY

**LEE'S SUMMIT**

Date: 06/24/2019

Applicant File # 2019-01

Applicant Name Aristocrat Motors

---

## REDEVELOPMENT PROJECT APPLICATION

Application must be submitted with six (6) exact copies. A non-refundable filing fee is required with this application in the amount of \$1,500.00. All third party costs, including professional services, legal, title, appraisal, due diligence, recording fees, etc. if borne by the LCRA shall be reimbursed from the applicant / developer. If necessary and required by the LCRA, an executed Funding Agreement may be required to be executed prior to processing the application.

---

### I. APPLICANT INFORMATION

Applicant/Organization Name: Aristocrat Motors

Business Address: 9415 W 65th Street, Merriam, KS 66203

Contact Person: Kevin Killilea Telephone #: 913-677-7407

Facsimile #: \_\_\_\_\_ E-mail: Kevin.Killilea@Soaveauto.com

Address (if other than business address): \_\_\_\_\_

Agent for Applicant: David Belpedio and Beth Lattin, MarksNelson LLC Telephone #: 816-743-7700

Facsimile #: 816-743-7701 E-mail: dbelpedio@marksnelsoncpa.com, tanderson@marksnelsoncpa.com

Agent Address: 1310 E 104th Street, Kansas City, MO 64131

---

**II. BUSINESS INFORMATION**

**A.** In what line or lines of business is the applicant engaged?

Auto Dealership

---

**B.** Is the applicant (or its parent) a proprietorship, partnership, or corporation?

Corporation

---

**C.** Year and State of incorporation: 1999 in Michigan

**D.** List the names and titles of the officers of the applicant firm:

Name	Title	Telephone #
Marion Battaglia	President	913-208-5100
Kevin Killilea	Vice President	816-935-0475
Bryan Frank	Treasurer	913-677-3300

---

**E.** Describe all outstanding or threatened litigation: *(Attach separate sheet if necessary)*

None

*(Provide the same information requested above for the parent company, if applicable)*

**III. LOCATION OF THE PROJECT**

General Boundaries: *(Attach separate sheet if necessary)*

Council District: District 1

Total Acreage: 2.83

Is the project located in any incentive areas? *(Attach separate sheet if necessary)* LCRA

---

What is the current zoning of the project area? ps planned commercial service

What is the proposed zoning for the project area? No change

This property is located in the following Urban Renewal Area (*if applicable*):

US 50 / M29 Hwy Urban Renewal Area

#### IV. THE PROJECT

- A. Provide a detailed narrative description of the proposed project, including information as the size of the project, amount of land (property) to be purchased, whether the project is a rehabilitation of existing structure(s), expansion, or the construction of a new facility, residences, etc. Describe what products or services are to be manufactured or provided through this project. (*Attach separate sheet if necessary*) See attached
- B. Does the applicant or its parent company presently have offices or industrial facilities located in Lee's Summit, Missouri? If so, describe. (*Attach separate sheet if necessary*) No
- C. List any nationally or locally historical properties and/or districts within the Project Area. N/A
- D. If a zoning change is pending, cite application number and present status. If application has not been made, briefly describe what change will be needed and plans for submitting application: (*Attach separate sheet if necessary*) N/A

#### V. COMMUNITY IMPACT STATEMENT

- A. Describe the project's integration within the applicable Lee's Summit Comprehensive Master Plan, conformance with the adopted Economic Development Incentive Policy or applicable adopted plan within the community. (*Attach separate sheet if necessary*)
- B. How many people will be employed by the project? (*Attach separate sheet if necessary*) 11
- Will this project represent an increase in employment opportunities in Lee's Summit, Missouri?  
Yes
  - Number of jobs to be retained.  
N/A

- C.** Projected real and personal property investment.  
The building and site work will cost around \$4,000,000 and personal property will be around \$250,000.
- D.** Describe the capability of the project to attract sales from outside the City, if applicable.  
Yes. We will attract many customers from the surrounding areas including Platte, Jackson and Johnson Counties in Missouri as well as Wyandotte and Johnson County Kansas.
- E.** Will this project attract additional residents to the area?  
N/A
- F.** Are there plans for future expansion?  
Yes, eventually we would like to purchase the skating rink to the east and add a service area.
- G.** What environmental impact will this project have on the area?  
None
- H.** Will there be the use of federal or state incentives for this project?  
N/A
- I.** Provide evidence of the need for the abatement (i.e., competitive pressures of the location, need for remediation of blight in proximity to the project, addition of jobs to a high unemployment area, etc.)  
Our business is very inventory heavy. This dealership is a completely new business model for us in a location we currently do not serve.
- J.** Describe the estimated impact to proximate businesses, particularly to businesses selling similar products or services in the area.  
While there are other auto dealerships in the area, the brands of the autos being sold by Aristocrat are not currently offered in the Lee's Summit market place. Such brands will likely result in accretive auto sales in the City of Lee's Summit given that likely buyers will be those buyers who had purchased such cars at other dealerships throughout the entire metro area.



**VI. PROJECT COSTS:**

Identify the costs reasonably necessary for the acquisition of the site and/or construction of the proposed Project together with any machinery and equipment in connection therewith, including any utilities hook-up, access roads, or appurtenant structures.

Item	Amount	Costs to be Financed with Bond Proceeds, if Applicable
Acquisition of Land and Existing Buildings	<b>\$1,500,000</b>	
Relocation costs (if applicable)		
Construction Costs:		
1. Architectural and Engineering	<b>\$205,000</b>	
2. Site Preparation	<b>\$95,000</b>	
3. Materials	<b>\$1,700,000</b>	
4. Labor		
5. Construction Contracts		
6. Utilities Connection		
7. Paving and Landscaping		
Renovation Cost		
Machinery and Equipment	<b>\$250,000</b>	
Furniture and Fixtures	<b>\$250,000</b>	
Capitalized Interest (From To)		
Cost of Issuance (i.e. accounting, legal, etc.)		
Contingency/Professional Fees		
<b>TOTAL PROJECT COSTS</b>	<b>4,000,000</b>	

Current Fair Market Value of Land: \$150,750

Fair Market Value of Improvement: \$0

Current Assessed Value of property: \$48,968

Projected Assessed Value of the Land & Improvements Upon Completion:  
\$1,300,000

Please outline specific request for abatement (requested amount, percentage and number of years for abatement).

- Total amount of property tax abatement requested: \$ \$895,961
- Percentage of abatement requested: 100%
- Number of years of abatement: 5yrs.

Please provide estimated schedule of property tax abatement for the requested timeframe for abatement (not to exceed 100% for 10 year period)

**Assumed new value of \$3,500,000 with 2% increase on reassessment on a go-forward basis.**

	<u>75% abatement</u>
Year 1	\$86,083
Year 2	\$86,083
Year 3	\$87,805
Year 4	\$87,805
Year 5	\$89,561
Year 6	\$89,561
Year 7	\$91,352
Year 8	\$91,352
Year 9	\$93,179
Year 10	\$93,179

**VII. SOURCES OF FUNDS:**

State amount and sources of financing for all of the Project costs listed above. Please provide commitment letters for any sources received listing terms and conditions.

<b>SOURCES</b>	<b>AMOUNT</b>
Cash	1,000,000
Loan	3,000,000

**VII. DEVELOPMENT TEAM**

Identify members of the development team and provide evidence of experience with other development projects.

---

---

**VIII. OPERATING PROFORMA.**

The proforma must cover the period of abatement requested.

**X. BOND FINANCING**

Bond Financing is handled on a case-by-case basis.

**XI. REQUIRED ATTACHMENTS:**

- **Attachment A:** A map showing the boundaries of the project.
- **Attachment B:** A map indicating current land use and zoning.
- **Attachment C:** A map indicating the proposed land use and zoning.
- **Attachment D:** A map showing infrastructure improvements to be made.
- **Attachment E:** A development schedule for the project, including the phasing of development and the locations and improvements to be accomplished in each phase.
- **Attachment F:** Design plans for the project (including site plans & elevations).
- **Attachment G:** Photographs of the project site and/or structure to be rehabilitated.

- **Attachment H:** Copy of preliminary title work.
- **Attachment I:** Letter(s) of Support from one or more of the following: councilpersons, mayor, county official, state representative, state senator, local taxing entities, and/or neighborhood organization(s).

**XII. CERTIFICATION OF APPLICANT:**

The undersigned hereby represents and certifies that to the best knowledge and belief of the undersigned, this project application contains no information or data, contained herein or in the exhibits or attachments, that is false or incorrect, and that it is truly descriptive of the property which application is being made.

NAME: \_\_\_\_\_

SIGNATURE: \_\_\_\_\_

TITLE: \_\_\_\_\_

**RETURN COMPLETED APPLICATION AND NON-REFUNDABLE APPLICATION FEE TO:**

**Land Clearance for Redevelopment Authority  
c/o City of Lee's Summit  
220 SE Green Street  
Lee's Summit, Missouri 64063**

**REDEVELOPMENT PROJECT APPLICATION**  
**EXHIBIT "1"— BUDGET / PROFORMA**

## REDEVELOPMENT PROJECT APPLICATION

### EXHIBIT "2"— NEW AND EXISTING EMPLOYMENT INFORMATION

New Jobs in Lee's Summit:

Sales Manager -- \$150,000 salary  
Assistant Sales Manager -- \$100,000 salary  
Salespeople (6) -- \$80,000 salary  
Office Assistant -- \$40,000 salary  
Porters (2) -- \$40,000 salary

11 jobs

2 Parcels

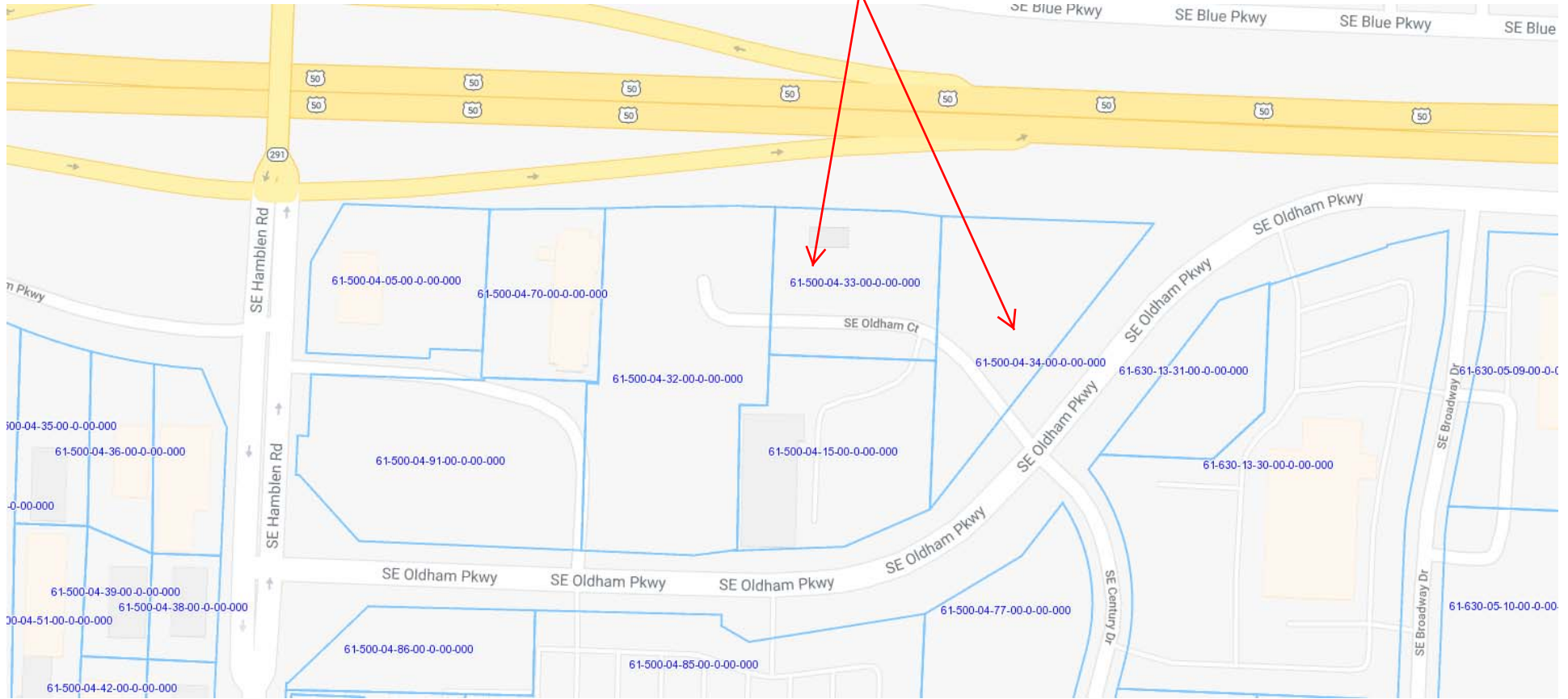

# REDEVELOPMENT PROJECT APPLICATION

## ATTACHMENT "B"—Map of Current Land Use and Zoning

ArcGIS Zoning Information

Sign In

Details Basemap

Share Print Measure Find address or place

About Content Legend

Legend

Zoning Overlay

- Airport Hazard Overlay
- Corridor Development Overlay
- Historic Overlay
- Neighborhood Stabilization Overlay

Zoning

- AG - Agricultural
- CBD - Planned Central Business District
- CS - Planned Commercial Services
- CP-1 - Planned Neighborhood Commercial
- CP-2 - Planned Community Commercial
- NFO - Neighborhood Fringe Office
- PI - Planned Industrial
- PMIX - Planned Mixed Use
- PO - Planned Office
- PRO - Planned Residential Office
- R-1 - Single Family Residential

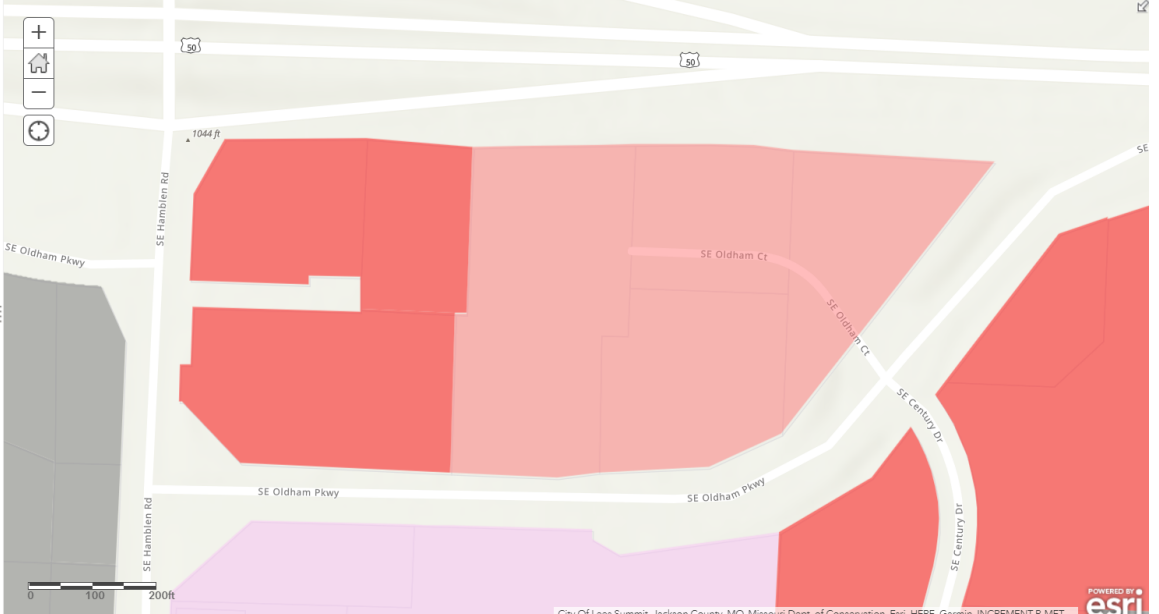

Esri.com Help Terms of Use Privacy Contact Esri Report Abuse

City Of Lees Summit, Jackson County, MO, Missouri Dept. of Conservation, Esri, HERE, Garmin, INCREMENT P, MET... **esri**



**REDEVELOPMENT PROJECT APPLICATION**  
ATTACHMENT "C"—Map of Proposed Land Use and Zoning

No zoning change required

**REDEVELOPMENT PROJECT APPLICATION**

ATTACHMENT "D"—Map of Proposed Infrastructure Improvements

**REDEVELOPMENT PROJECT APPLICATION**  
ATTACHMENT "E"—Development Schedule

It is projected that the groundbreaking will take place in October 2019 with the completion date of March/April 2020

REDEVELOPMENT PROJECT APPLICATION

ATTACHMENT "G"—Photographs of project site and/or structure to be rehabilitated





































**GENERAL NOTES:**

- The recorded plat, Oldham East Business Park was used in preparation of this Final Development Plan.
- Cross Access easements for common driveways and adjoining parking lots will be provided on the Final Plat.
- There is no visible evidence of abandoned oil or gas wells located within the plot boundary, as identified in "Environmental Impact Study of Abandoned Oil and Gas Wells in Lee's Summit, Missouri", Edward Alton May, Jr., P.E., 1995.
- Mechanical units shall be totally screened from view in accordance with Article 7 of the UDO.
- All materials, colors, and architecture of buildings to meet the requirements of section 7.280 of the current UDO.
- Contractor to locate and relocate any existing utilities that may conflict with construction as necessary.
- The development shall meet the requirements of the Unified Development Ordinance, Design and Construction Manual, Access Management Code and other ordinance for development including, but not limited to, parking setbacks and spaces, ADA requirements, site lighting, landscaping and screening, utilities, and zoning requirements.
- Every ADA accessible parking space shall be identified by a sign, mounted on a pole or other structure, located between 36 inches and 60 inches above the ground, measured from the bottom of the sign, and the head of the parking space.
- All identifying signs shall be 12 inches wide by 18 inches in height and meet the requirement set forth in the Manual on Uniform Traffic Control Devices, as referenced in the Lee's Summit General Code of Ordinances.
- All Landscaping to meet Article 14 of the UDO.
- There shall be two way traffic movement.
- See architectural submittal for all building dimensions, monument signs and lighting details.
- Parking lot screening to meet UDO.
- Exterior lighting to conform to UDO requirements (400 watt lamp, 18' maximum pole height and 90' cut-off for light dispersion).
- All curb to be CG-1 curb, unless otherwise noted.
- Easements are provided for ingress/egress as shown and per the recorded plat.
- Parking Spaces shall be 9' x 19' (perimeter w/ curb), 9' x 19' (interior center), and 9' x 20' (interior w/ no curb).
- Watershed: East Fork-Little Blue River (to Prairie Lee Lake)
- A minor plat will be prepared to combine the two lots into 1 lot. A private easement for the sanitary sewer service for the Landmark Skate Center building will be dedicated on the plat.
- All dimensions are to back of curb unless otherwise noted.
- All curb radii within parking lot are 5' unless otherwise noted.
- Knox padlocks shall be provided on the gates per IFC 506.1. The key box shall be of an approved type listed in accordance with UL 1037, and shall contain keys to gain necessary access as required by the fire code official.

- STREETS:**
- Improvements to the main entrance off of SE Oldham Parkway shall consist of curb & gutter addition only. No sidewalk is required for the road frontage for this property.
- BUILDING LINES:**
- Minimum required building line is 20 feet on 50 Hwy frontage, 20 feet on West side of the property, and 10 feet on South side of the property.
- PARKING SETBACK LINES:**
- Minimum required parking setback line is 20 feet on 50 Hwy frontage, 20 feet on West side of the property, and 10 feet on South side of the property.
- SIDEWALKS:**
- Interior sidewalks are 5' as shown. Sidewalks to be 5' PCC on 4' of compacted gravel.

**PROJECT DATA:**  
 The site is Zoned CS  
 Project Area - 2.83 acres  
 Number of Lots - 2  
 Density - 1.90 lots/acre

**PHASING:**  
 - The project infrastructure as shown shall be completed in 1 phase.

**PARKING:**  
 - Parking Spaces Required/Provided - 18/18  
 Garage - 3/boy x 4 bays = 12  
 Sales Area - 2/1000sf - 2.1 x 2 = 4.2 (5)  
 Outside Display Area - 1/2500sf, 6 display pads: at 200sf each - 1200sf = 0.48 (1)  
 ADA Spaces Required/Provided - 1/1

**SITE ADDRESS:**  
 704 SE Oldham Court, Lee's Summit, MO 64081

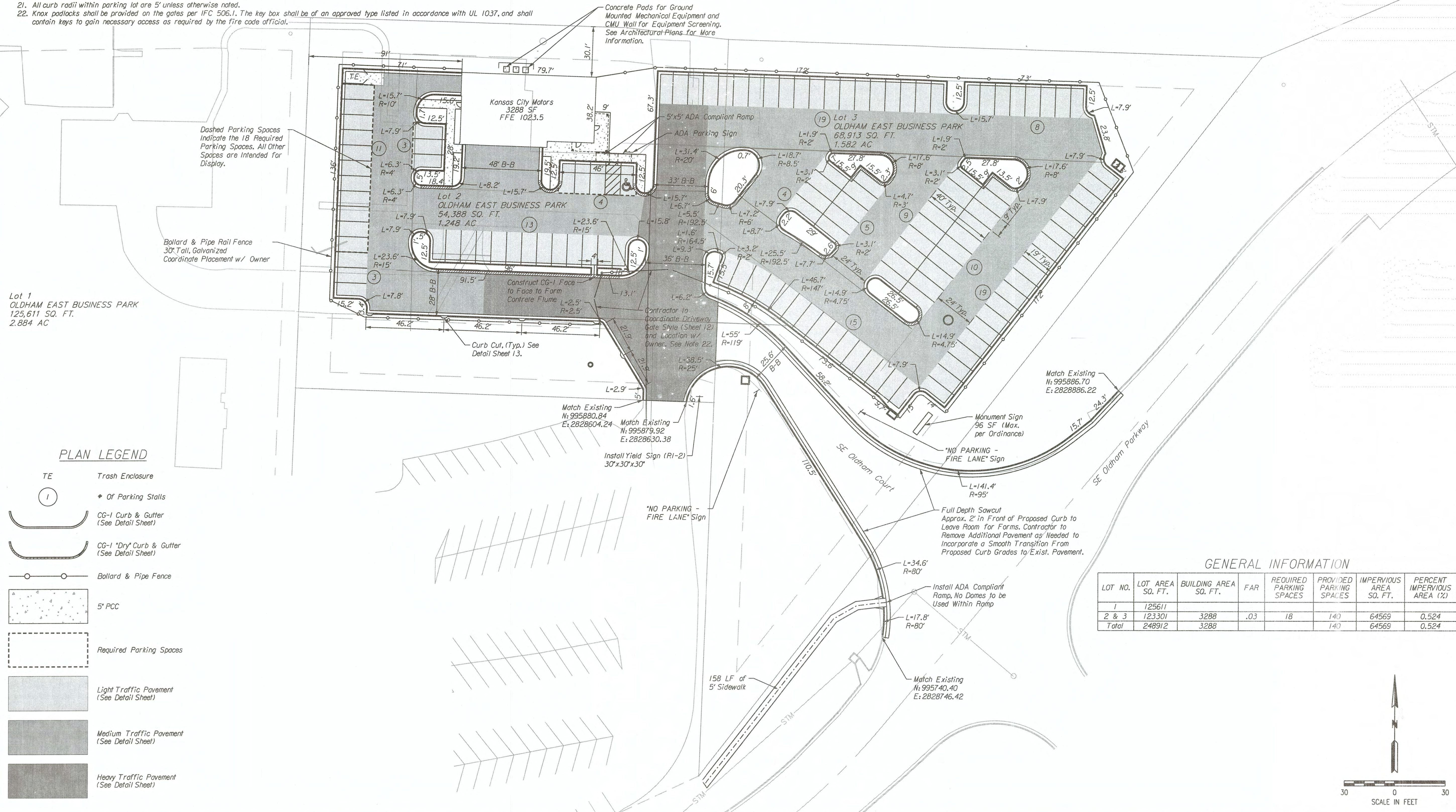

Lot 1  
 OLDHAM EAST BUSINESS PARK  
 125,611 SQ. FT.  
 2.884 AC

Kansas City Motors  
 3288 SF  
 FFE 1023.5

Lot 2  
 OLDHAM EAST BUSINESS PARK  
 54,388 SQ. FT.  
 1.248 AC

Lot 3  
 OLDHAM EAST BUSINESS PARK  
 68,913 SQ. FT.  
 1.582 AC

**PLAN LEGEND**

TE	Trash Enclosure
(I)	Of Parking Stalls
(C)	CG-1 Curb & Gutter (See Detail Sheet)
(D)	CG-1 "Dry" Curb & Gutter (See Detail Sheet)
(F)	Ballard & Pipe Fence
(P)	5' PCC
(R)	Required Parking Spaces
(L)	Light Traffic Pavement (See Detail Sheet)
(M)	Medium Traffic Pavement (See Detail Sheet)
(H)	Heavy Traffic Pavement (See Detail Sheet)

**GENERAL INFORMATION**

LOT NO.	LOT AREA SQ. FT.	BUILDING AREA SQ. FT.	FAR	REQUIRED PARKING SPACES	PROVIDED PARKING SPACES	IMPERVIOUS AREA SQ. FT.	PERCENT IMPERVIOUS AREA (%)
1	125611						
2 & 3	123301	3288	.03	18	140	64569	0.524
Total	248912	3288			140	64569	0.524

NO.	BY	DATE	REVISION
1			
2			
3			

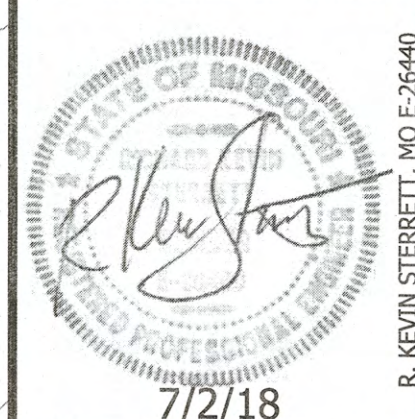

7/2/18

**Consult Inc**  
 engineers  
 Inc  
 planners

1100 Haskell St. Ste 210 Kansas City, MO 64108 816-759-2285  
 CORPORATE LICENSE NO. E2010005973

**DIMENSION PLAN**

**KANSAS CITY MOTORS**  
 LEE'S SUMMIT - JACKSON COUNTY - MISSOURI

X-REF. NO. XXX  
 DRAWING NO. XXX  
 DATE July 2018  
 JOB NO. 16.045.01

3 SHEET OF 17

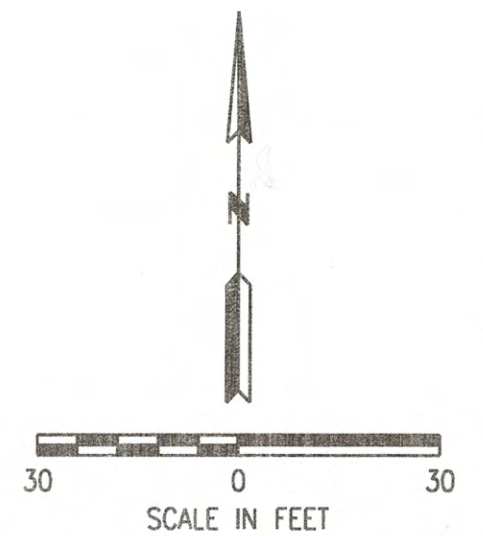



**GENERAL NOTES:**

1. See detail sheet for pavement section and details.
2. All slopes to be 3:1 max.

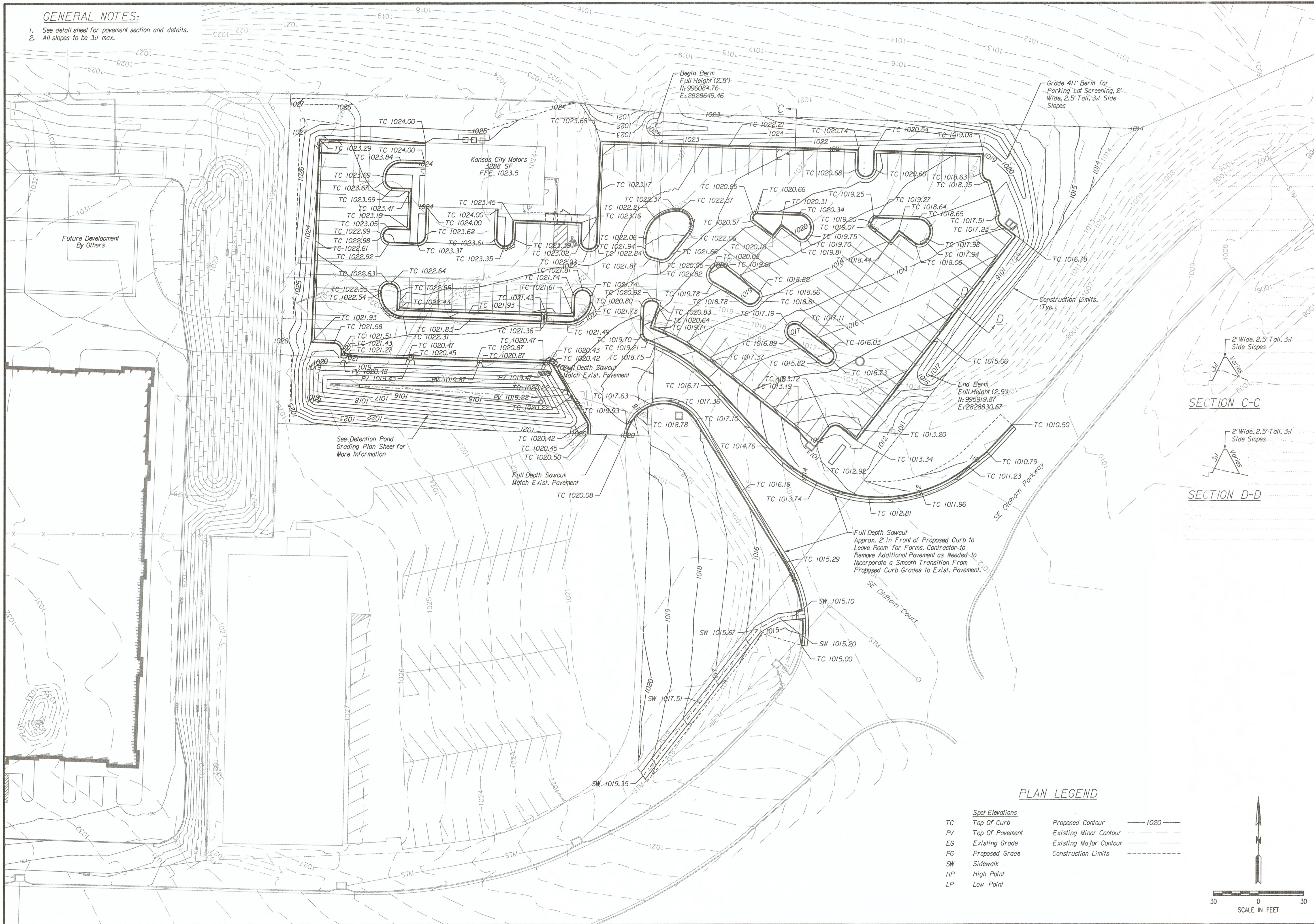

**PLAN LEGEND**

TC	Spot Elevations	Proposed Contour	1020
Top Of Curb		Existing Minor Contour	
PV	Top Of Pavement	Existing Major Contour	
EG	Existing Grade	Construction Limits	
PG	Proposed Grade		
SW	Sidewalk		
HP	High Point		
LP	Low Point		

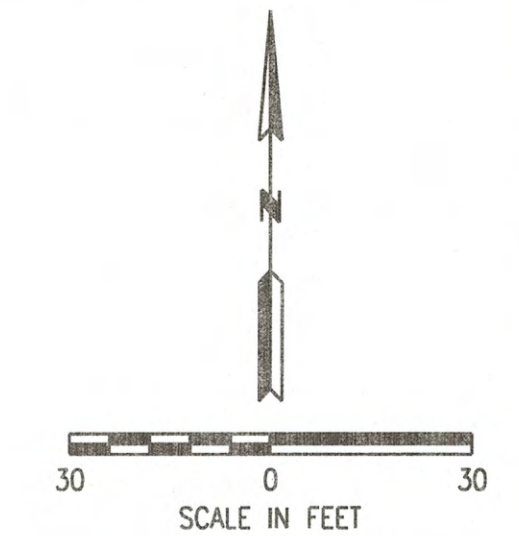

NO.	BY	CK/APP	DATE	REVISION
3	RUS			REMOVED DIVERSION BERM(S) W/AL
2	RUS			REVISED PER APPLICANT LETTER DATED 6/28/17
1	RUS			REVISED PER APPLICANT LETTER DATED 6/8/17

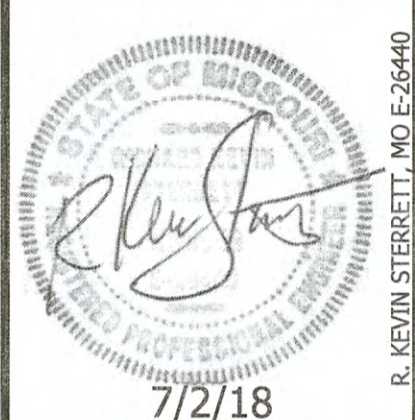

7/2/18

**Consult Inc engineers**  
Inc planners

11010 Haskell St., Ste. 210, Kansas City, MO 64116  
CORPORATE LICENSE NO. E201000873  
CORPORATE LICENSE NO. E-295-2285

<b>GRADING PLAN</b>	
<b>KANSAS CITY MOTORS</b>	
LEE'S SUMMIT - JACKSON COUNTY - MISSOURI	
X-REF NO. XXX	DRAWING NO. XXX
DATE July 2018	SHEET NO. 16,045,01
4	SHEET OF 17



**GENERAL NOTES:**

1. All storm sewer pipe to be HDPE w/ smooth interior.

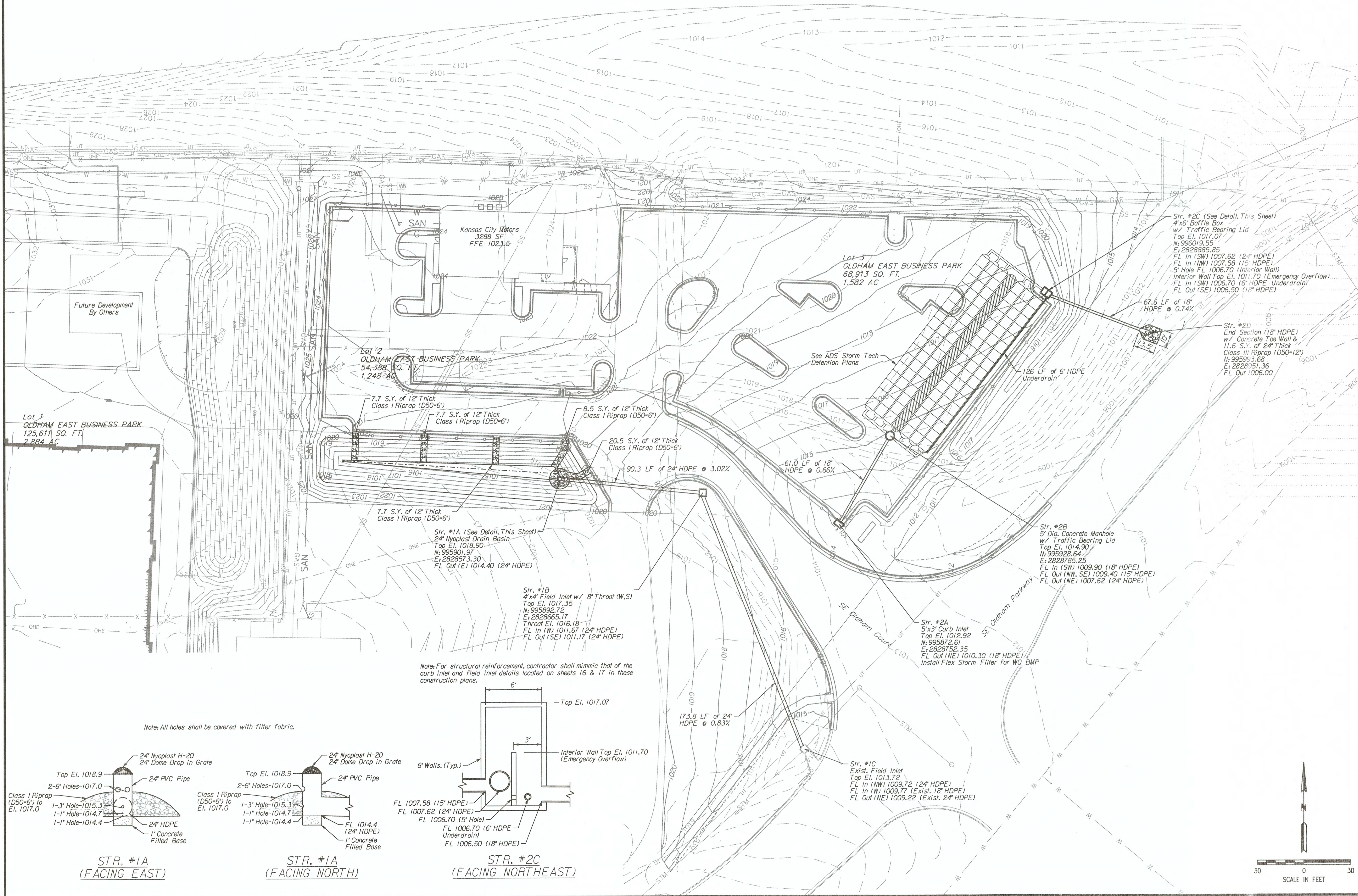

Note: All holes shall be covered with filter fabric.

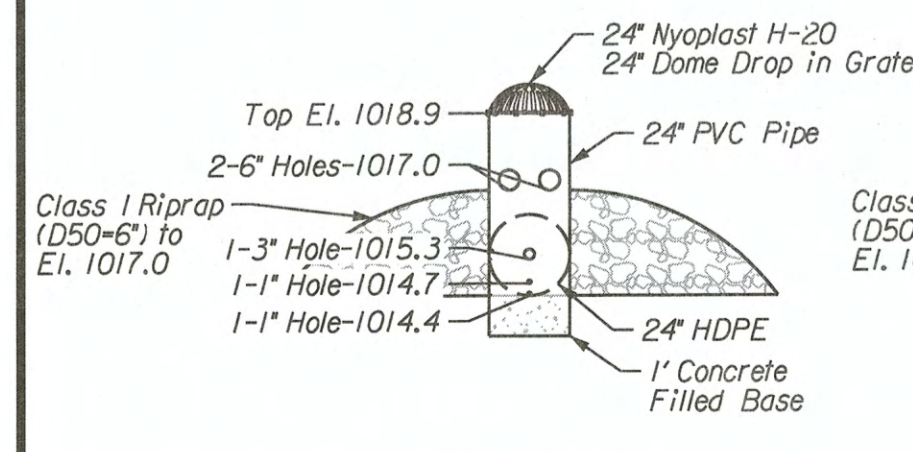

**STR. #1A  
(FACING EAST)**

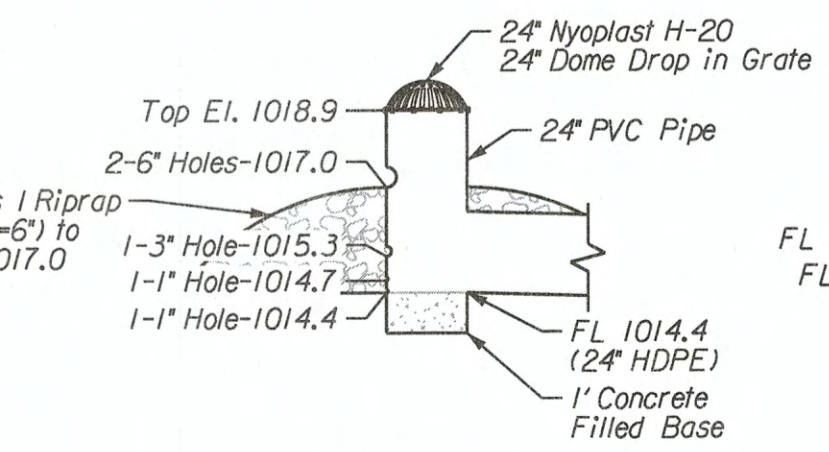

**STR. #1A  
(FACING NORTH)**

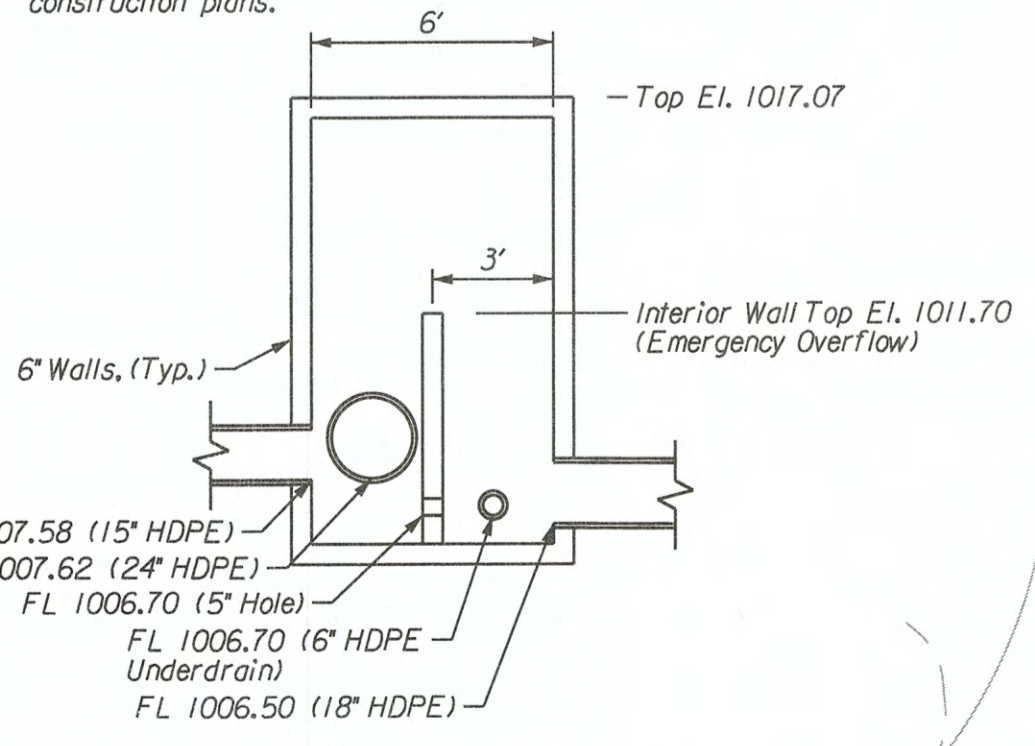

**STR. #2C  
(FACING NORTHEAST)**

Note: For structural reinforcement, contractor shall mimic that of the curb inlet and field inlet details located on sheets 16 & 17 in these construction plans.

NO.	DATE	REVISION	BY	CHK/APR
3		REMOVED DIVISION BERM/SVALE	RAM	RIS
2		REVISED PER APPLICANT LETTER DATED 6/28/17	RAM	RIS
1		REVISED PER APPLICANT LETTER DATED 6/9/17	RAM	RIS
1		REVISED PER APPLICANT LETTER DATED 6/9/17	RAM	RIS

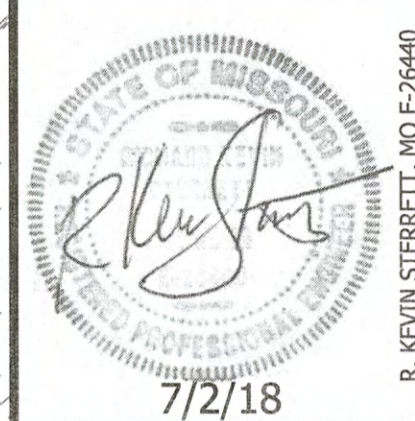

**consult inc**  
engineers  
planners

**8**

**STORM SEWER PLAN**  
**KANSAS CITY MOTORS**  
LEE'S SUMMIT - JACKSON COUNTY - MISSOURI

X-REF. NO.	XXX
DRAWING NO.	XXX
DATE	July 2018
JOB NO.	16.045.01
SHEET	7
OF	17

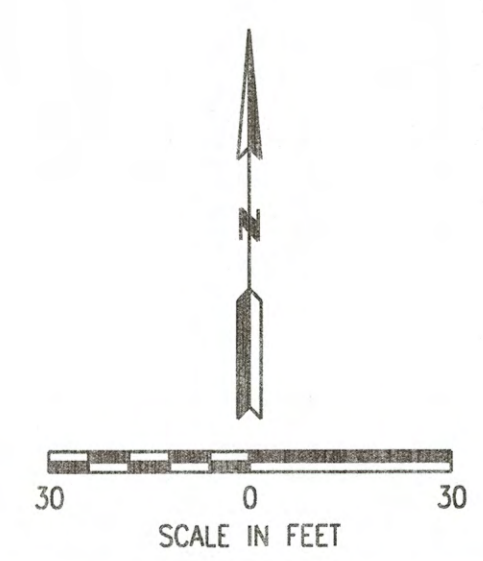

11010 Hustell St., Ste. 210 Kansas City, MO 64116-5295-2955 CORPORATE LICENSE NO. E201005573 R. KEVIN STERRETT, MO E-2640



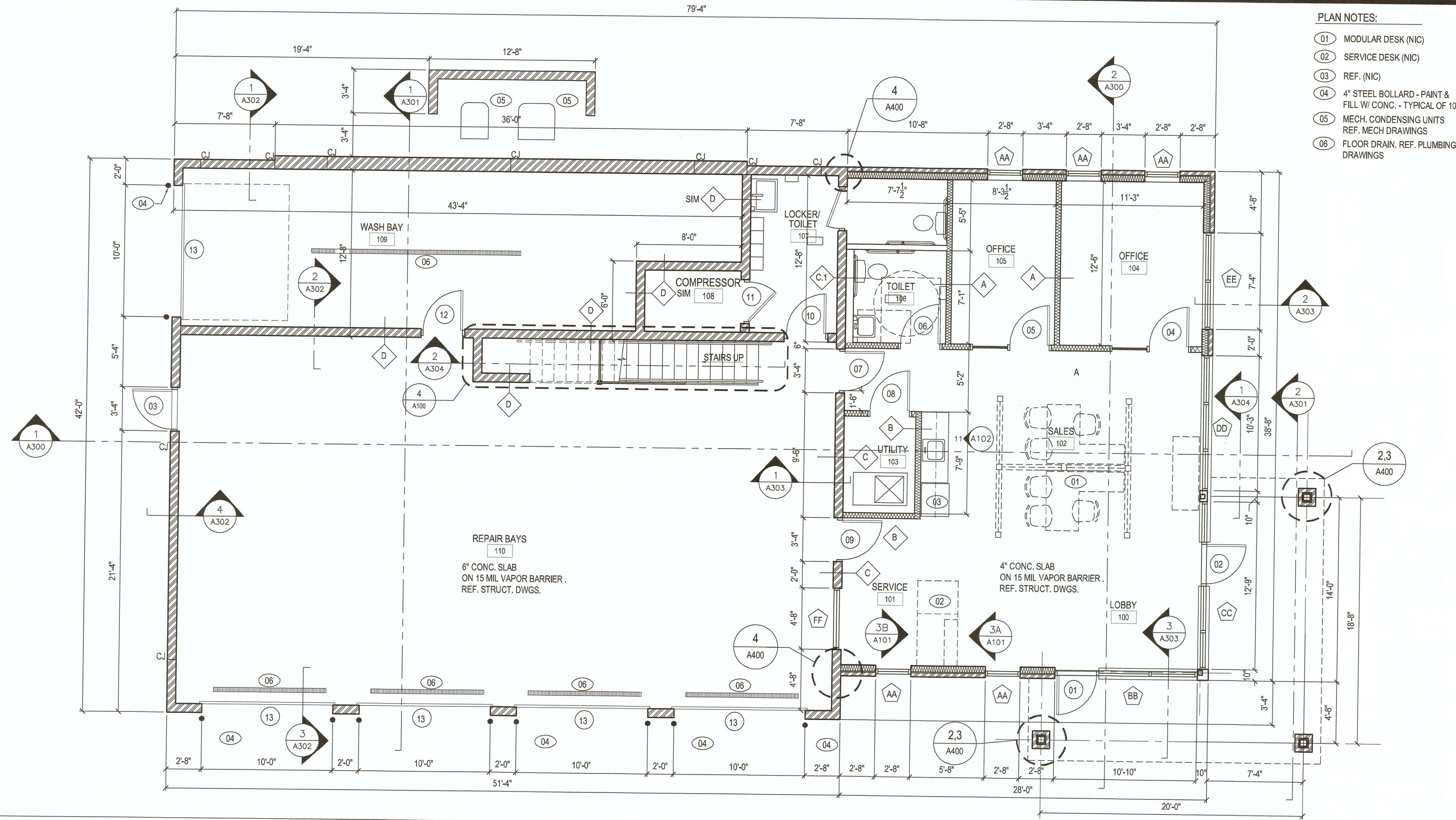

- PLAN NOTES:**
- 01 MODULAR DESK (NIC)
  - 02 SERVICE DESK (NIC)
  - 03 REF. (NIC)
  - 04 4" STEEL BOLLARD - PAINT & FILL W/ CONC. - TYPICAL OF 10
  - 05 MECH. CONDENSING UNITS REF. MECH DRAWINGS
  - 06 FLOOR DRAIN. REF. PLUMBING DRAWINGS

**1** Floor Plan - 3,200 SQ.FT.  
SCALE: 1/4"=1'

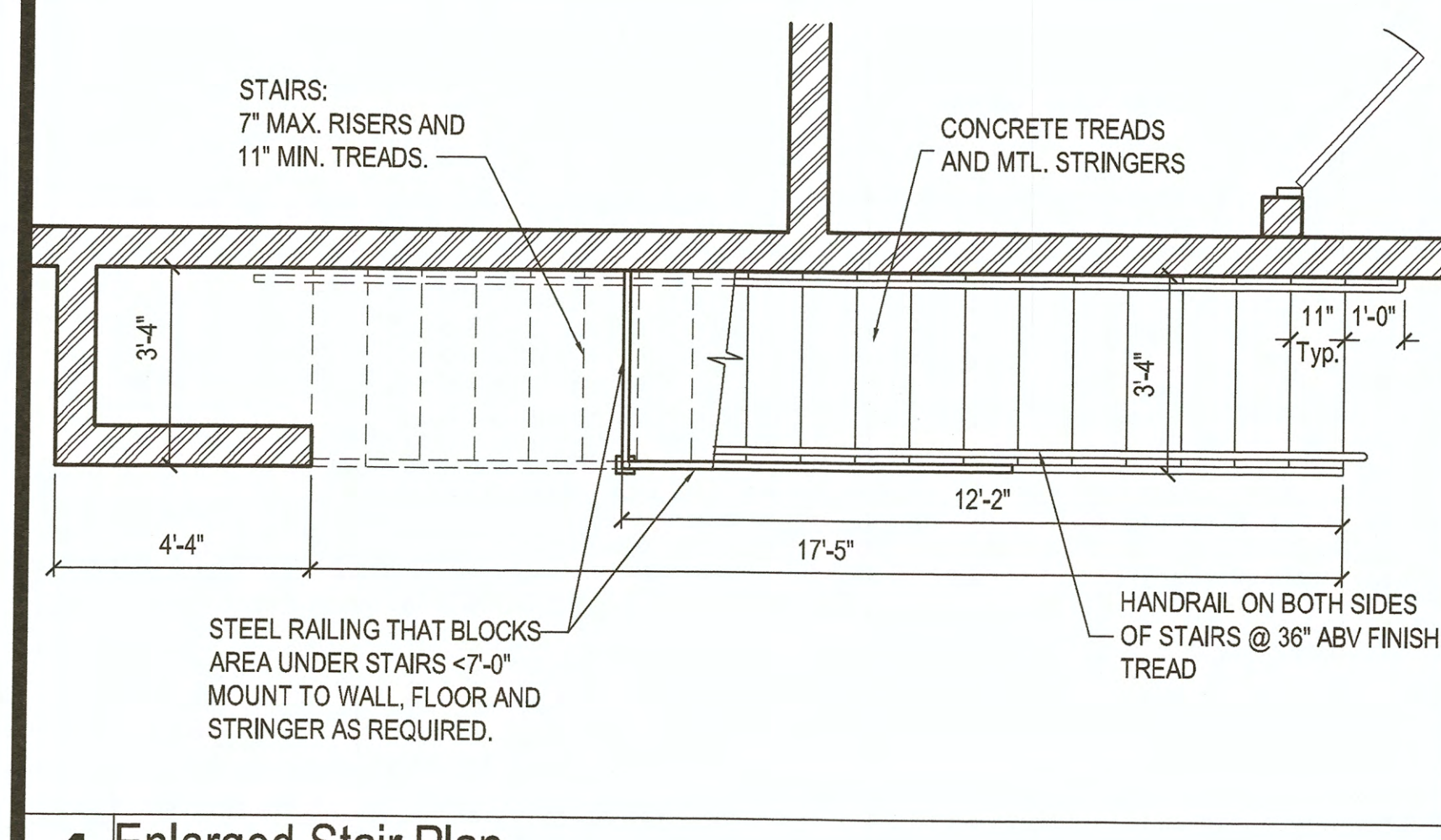

**4** Enlarged Stair Plan  
SCALE: 3/8"=1'

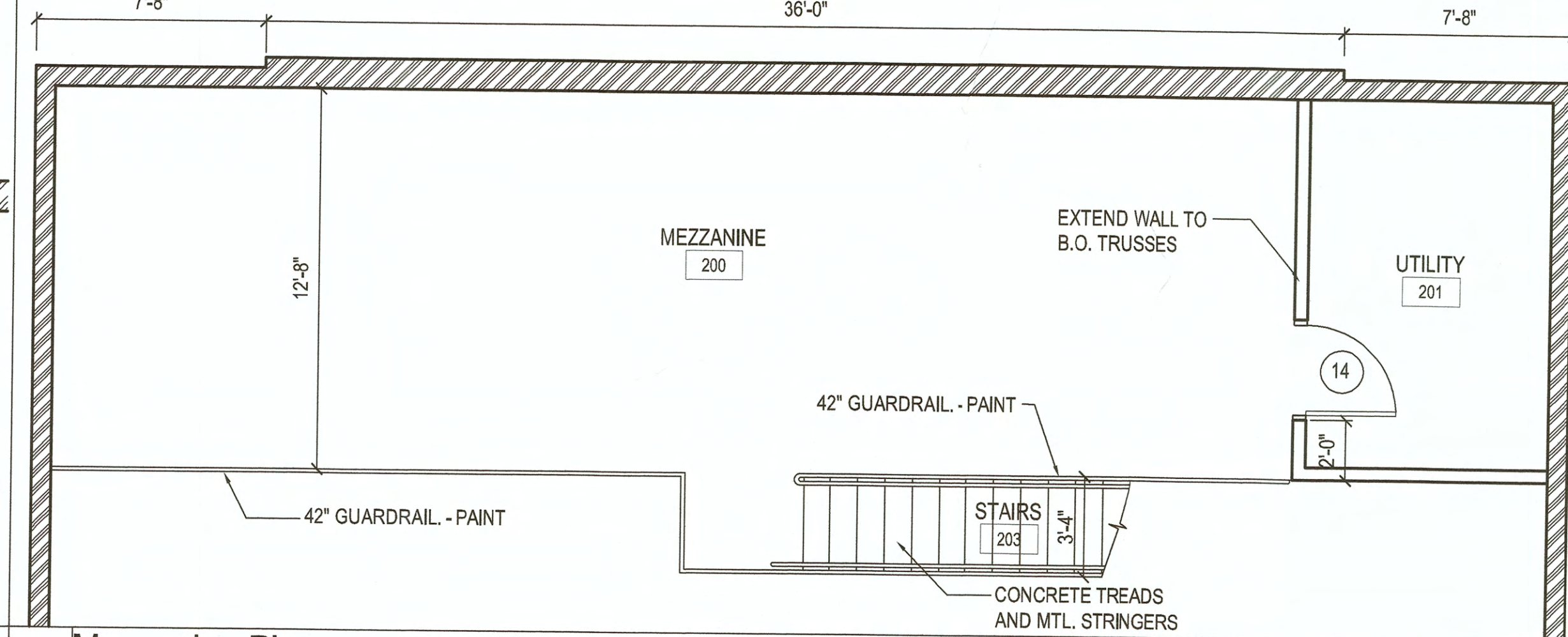

**3** Mezzanine Plan  
SCALE: 1/4"=1'

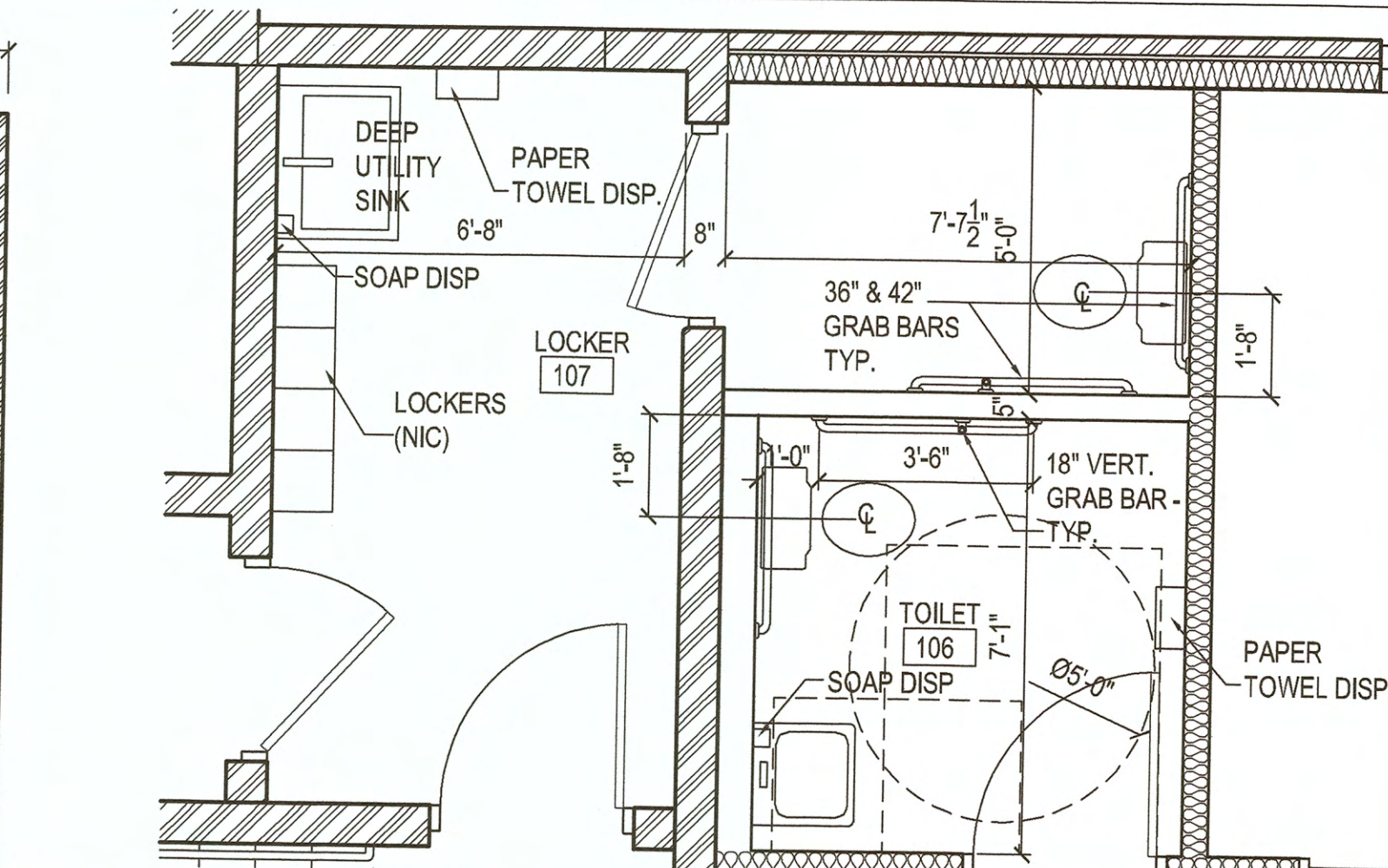

**2** Enlarged Toilet Plan  
SCALE: 3/8"=1'

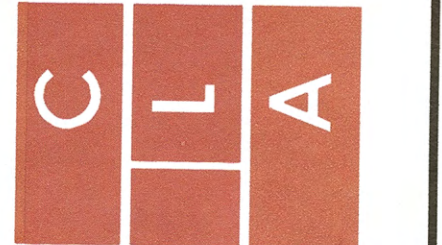

DATE ISSUED:  
5.21.18

REVISIONS:

ARCHITECTURAL PROJECT NUMBER

SHEET NUMBER  
**A100**



**NOTES:**  
 - Building Parking Lot and Landscaping information on each lot are for graphical purpose and do not represent the detailed final development plan information. All Landscaping to meet Article 14 of the UDO.  
 - All portions of the site not covered with paving or buildings shall be landscaped. All interior landscape areas shall be covered with sod as well as all areas adjacent to the building. All remaining areas shall be seeded. Ground cover shall be utilized on all slopes in excess of 3:1 slope.

**LANDSCAPE SCHEDULE:**  
**SPECIES** **CALIPER/HEIGHT**

- ☉ Sterling Silver Linden, State Street Miyabe Maple, Emerald Sunshine Elm 3"
- ☉ Tam Juniper, Gold Lace Juniper, Fireball Dwarf Burning Bush, Sunny Boulevard St. John's Wort 24" (Minimum height) At planting

**Worksheet for Tree and Shrub Requirements:**

- A - Size of development site = 123,301 SF
- B - Length of street frontage of development site = 1,105 LF
- C - Trees required on street frontage = 1/30 LF = 37 Trees
- D - Trees provided = 37 Trees
- E - Parking lot area = 55,503 SF
- F - Green space required in parking lot (E x 5%) = 2,775 SF
- G - Green space provided = 3,714 SF
- H - Shrubs required along frontage (Parking lot screen) = 171 Shrubs
- I - 569 LF at 12/40 LF (Berm accounts for 536 LF)
- J - Quantity of additional trees required = 24 Trees
- K - 1 tree per 5000 SF of open area (119,101/5000) = 24 Trees
- L - Additional Trees Provided = 24 Trees
- M - Quantity of additional shrubs required = 48 Shrubs
- N - 2 shrubs per 5000 SF of open area (119,101/5000) = 48 Shrubs
- O - Additional Shrubs Provided = 48 Shrubs

**Interior Landscape**

Area	SF
A	148
B	713
C	231
D	280
E	662
F	368
G	383
H	164
I	442
J	323
TOTAL	3,714

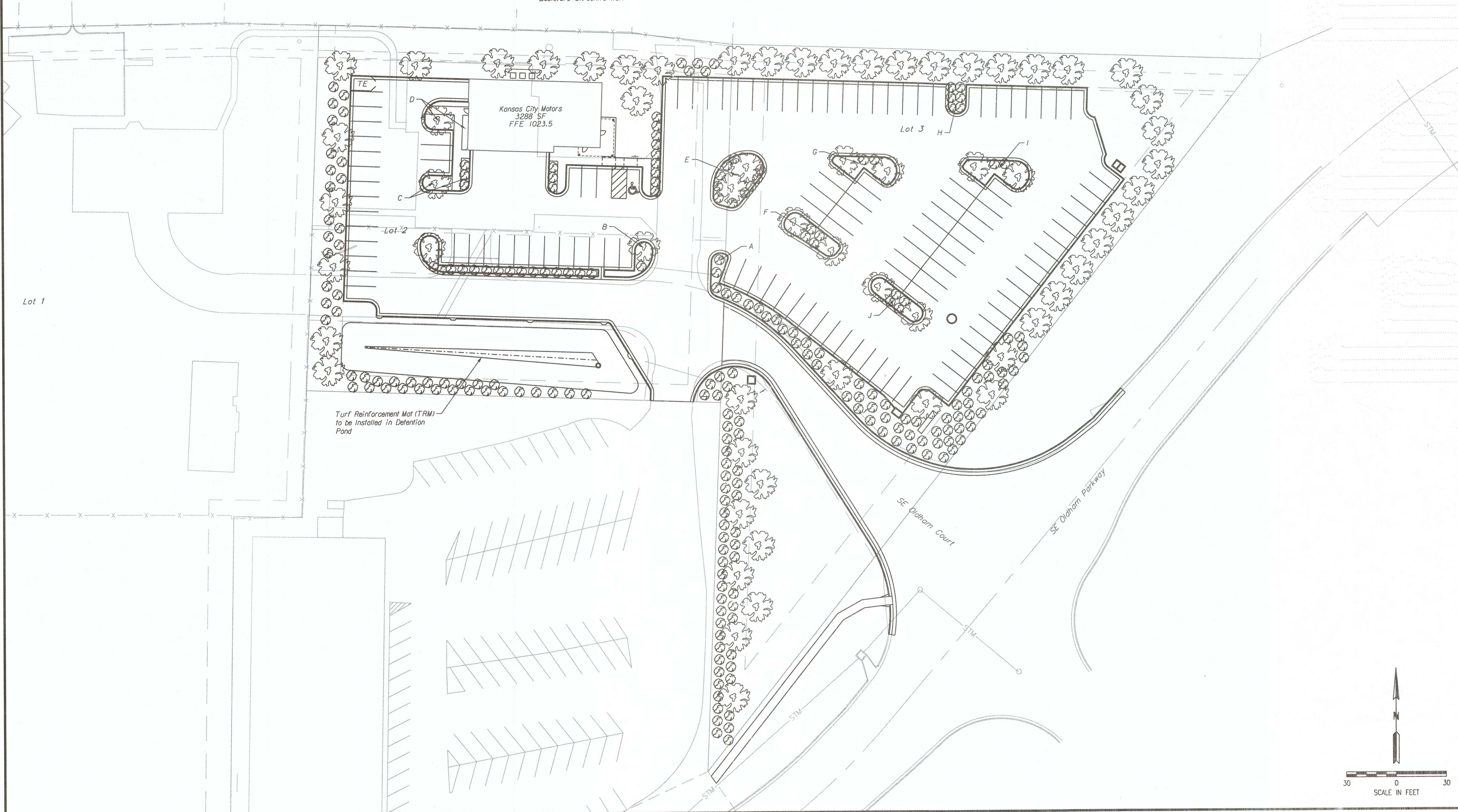

DATE	REVISION	NO.	BY	CHKAPP
7/2/18	REMOVED DIVERSION BERM/SWALE	3	RAM	RIS
7/6/17	REVISED PER APPLICANT LETTER DATED 6/28/17	2	RAM	RIS
6/16/17	REVISED PER APPLICANT LETTER DATED 6/8/17	1	RAM	RIS

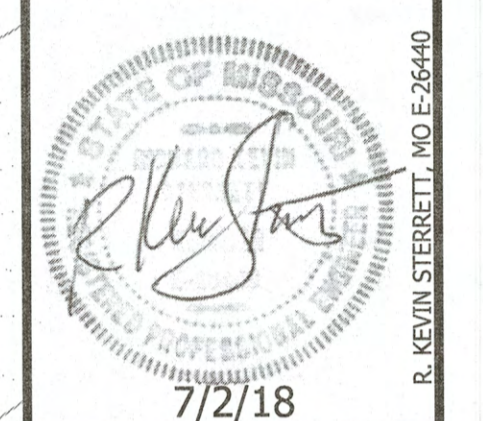

7/2/18  
**Consult Inc**  
 engineers  
 planners  
 11010 Hasbick St., Ste. 210, Kansas City, MO 64116  
 CORPORATE LICENSE NO. E2010005873  
 816.759.2285

LANDSCAPE PLAN  
**KANSAS CITY MOTORS**  
 LEE'S SUMMIT - JACKSON COUNTY - MISSOURI

X-REF NO. XXX  
 DRAWING NO. XXX  
 DATE July 2018  
 JOB NO. 16.045.01

10 SHEET OF 17